

REV	DATE	DESCRIPTION	ECO	BY	C'H'K.
C	05/08/2017 00:00:00 AM	LOGO UPDATE	46692	BK	MB

CATALOG NO.	CONDUCTOR		BOLT SIZE	FIG. NO.	DIMENSIONS								INSTALLATION TOOLING (# CRIMPS)													
	CODE (AWG)	NAVY			B ±.06	C ±.04	H REF.	K DIA. ±.02	L ±.09	N ±.04	O.D. ±.01	T REF.	Z MIN.	DIE INDEX	COLOR CODE	MECHANICAL			HYDRAULIC				DIELESS (# CRIMPS)	WIRE STRIP LENGTH		
																MD7-34R MD6	OUR840	Y2MR	BCT500 Y500CT	Y34A	Y750 Y35, BAT35 Y39, BAT750	Y46			Y45	
YAZ2CTC10	#2 AWG. [-----]	60	#10 M5	1	1.25 [32]	.60 [15]	--	.21 [5]	2.09 [53]	.25 [6]	.42 [11]	.11 [3]	.26 [7]	10	BROWN	W2CVT W2CRT (2)	W2CVT W2CRT (2)	-----	W2CVT W2CRT (2)	A2CR (2)	U2CRT (2)	U2CRT (2)	U2CRT (2)	MECHANICAL: MY29-11(1)  HYDRAULIC Y644, Y644M BAT644M Y644MBH, Y1000 Y1000BH (1)	1-5/16	
YAZ2CTC14	↑	↑	1/4 [M6]	1	↑	↑	--	.27 [7]	2.21 [56]	.31 [8]	↑	↑	.33 [8]	↑	↑	W2CVT W2CRT (2)	W2CVT W2CRT (2)	-----	W2CVT W2CRT (2)	A2CR (2)	U2CRT (2)	U2CRT (2)	U2CRT (2)			
YAZ2CTC1445				2					1.42 [36]																	2.01 [51]
YAZ2CTC1490				3					1.74 [44]																	.95 [24]
YAZ2CTC516				1					--																	2.27 [58]
YAZ2CTC51645	#2 AWG. [-----]	60	5/16 [M8]	2	1.25 [32]	.60 [15]	1.42 [36]	.33 [8]	2.08 [53]	.34 [9]	.42 [11]	.11 [3]	.36 [9]	10	BROWN	W2CVT W2CRT (2)	W2CVT W2CRT (2)	-----	W2CVT W2CRT (2)	A2CR (2)	U2CRT (2)	U2CRT (2)	U2CRT (2)			1-5/16
YAZ2CTC51690	3	1.25 [32]	.60 [15]	1.74 [44]	1.01 [26]																					

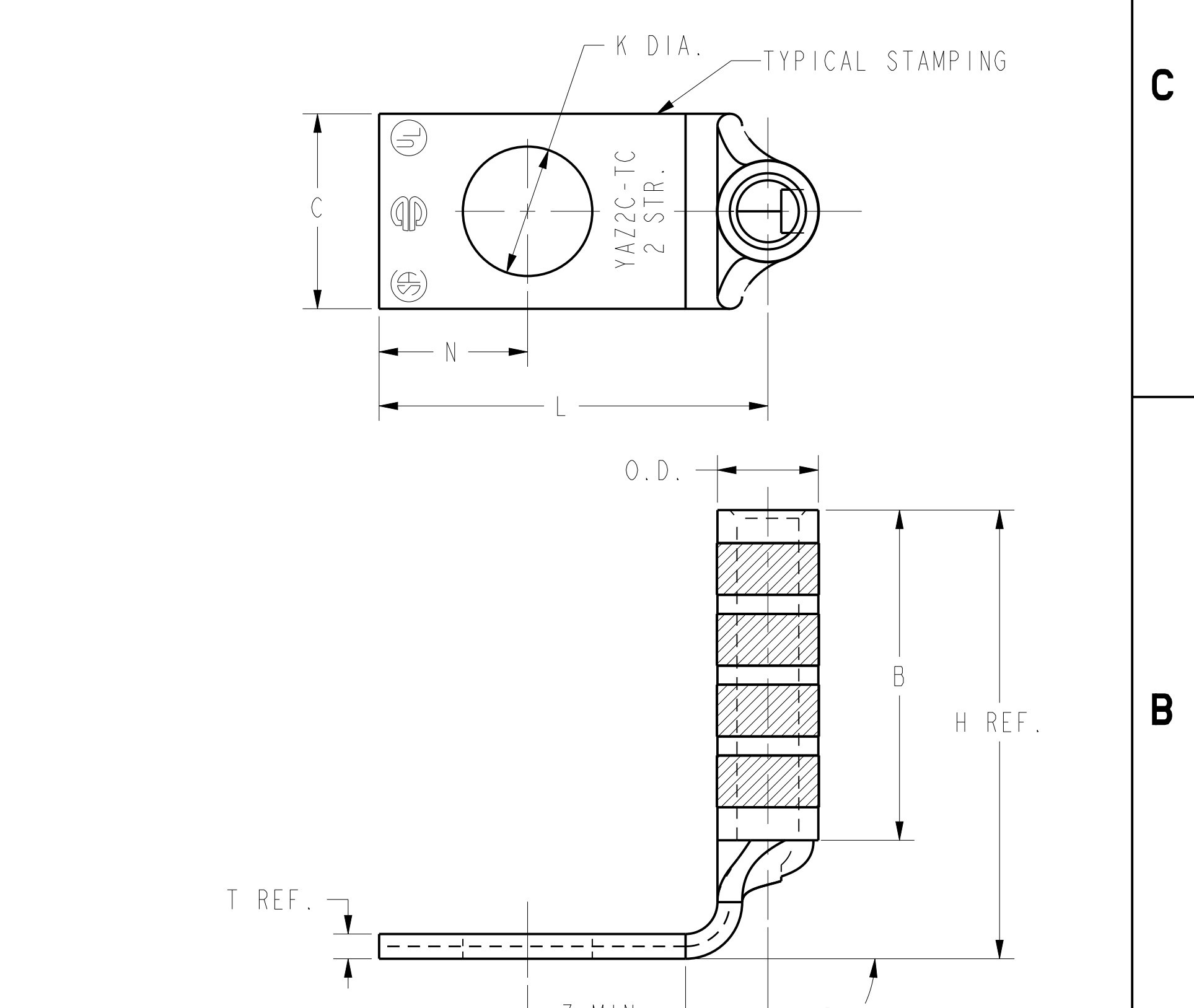
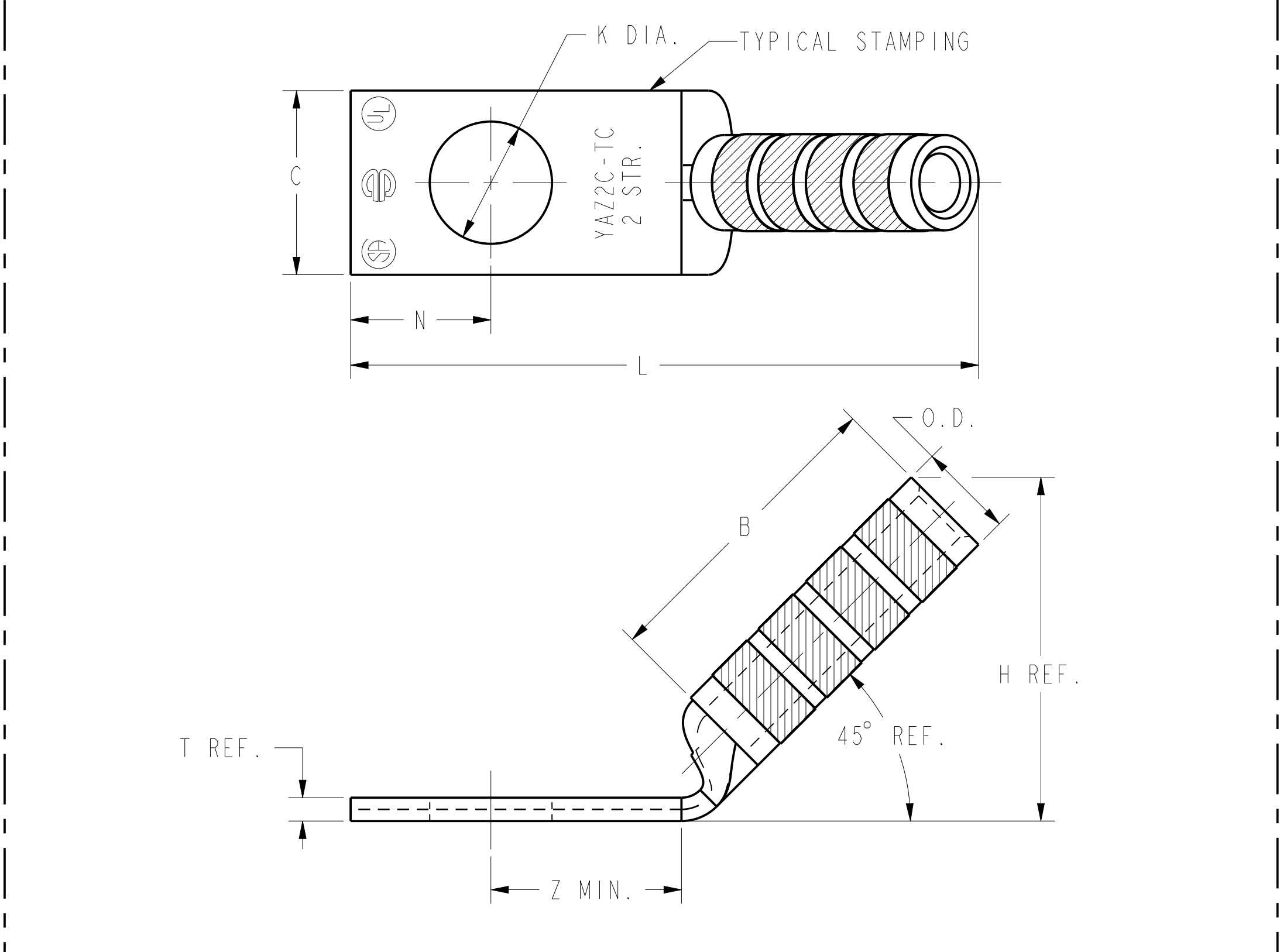
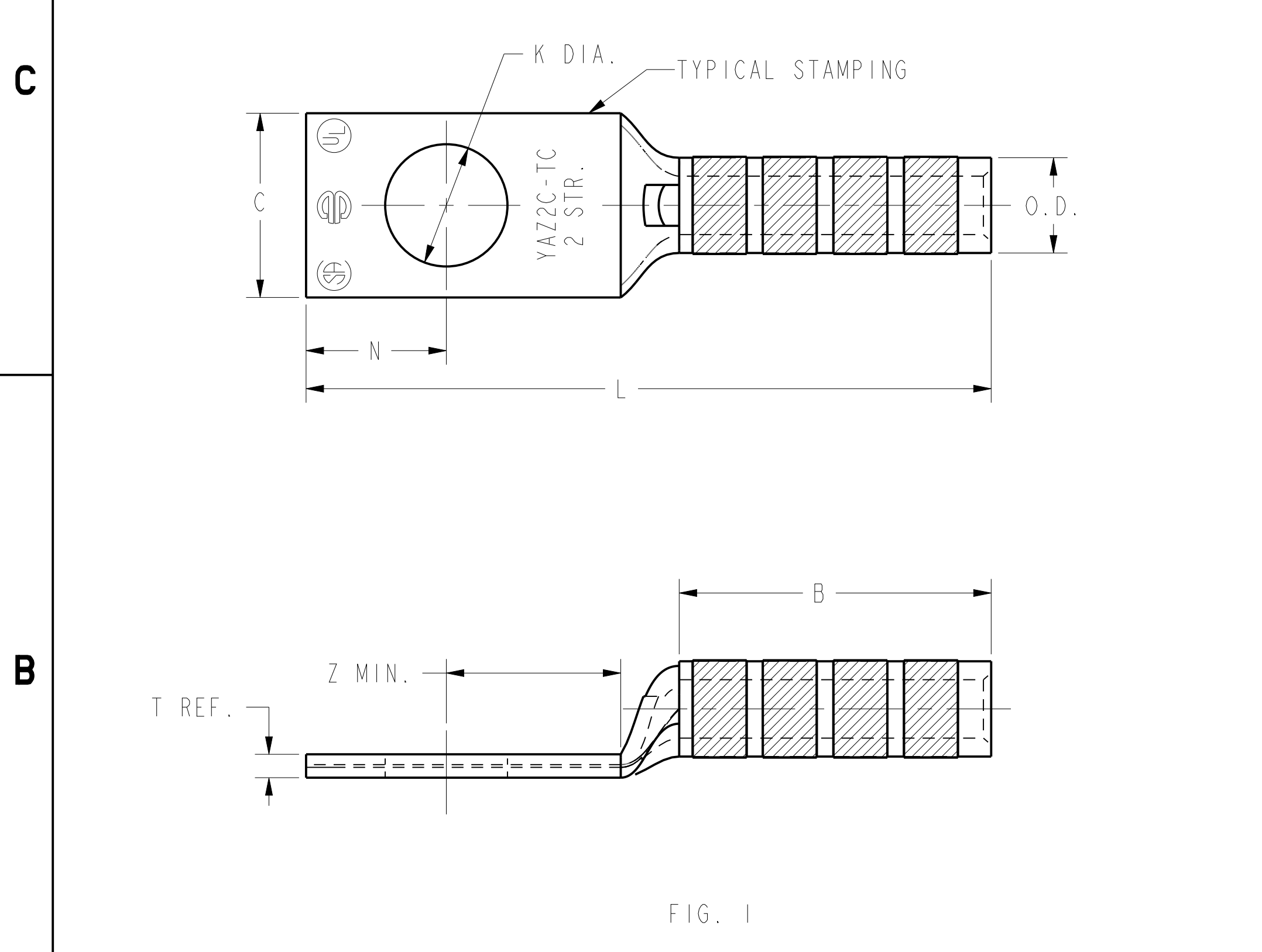

- NOTES:
- MATERIAL: COPPER TUBING.
  - FINISH: TIN PLATED
  - CATALOG # PT6515 ADAPTOR IS REQUIRED TO USE "U" DIES IN Y45 SERIES TOOLS.
  - CATALOG # PUADP-1 ADAPTOR IS REQUIRED TO USE "U" DIES IN Y46 SERIES TOOLS.
  - NAVY CABLE SIZE MAY BE OMITTED ON SOME SIZES BECAUSE OF SPACE LIMITATIONS.
  - PERMANENT DIE IN TOOLING.
  - DIMENSIONS, METRIC WIRE, & METRIC BOLT SIZES IN BRACKETS [ ] ARE IN MILLIMETERS. DIMENSIONS ARE ROUNDED OFF TO THE NEAREST MILLIMETER, UNLESS OTHERWISE NOTED, AND ARE FOR REFERENCE ONLY.
  - FOR USE BY CUSTOMERS THAT HAVE THIS HYPRESS™. NO NEW Y34A HYPRESS™ TOOLS ARE BEING PROCESSED.

TO ORDER BURNDY® PRODUCTS CALL		HYLUG™ (ONE HOLE CODE)	
UNITED STATES 1-800-346-4175 (LONDONDERRY, NH)		ITEM NO: NA	CAT. NO: YAZ2C-TC- (TABLE)
CANADA: 1-800-361-6975 (QUEBEC) 1-800-387-6487 (ALL OTHER PROVINCES)		DRAWN BY: D. BOISVERT 02/03/2000	CHECKER: K. MCCARTHY 04/05/2000
FOR PRODUCT INFO: <a href="http://www.burndy.com">http://www.burndy.com</a>		DSN APPVL: J.MICHAUD 05/04/2000	MFG APPVL: N/A
		GA APPVL: S.BROWN	MKT APPVL: N/A
		PROD FAM: --	DRAWING NO: REV
		PROJECT #: --	SIZE: SE212356
		DOCUMENT TYPE: Sales	SHEET 11 OF 40
		REL LEVEL: Released	