

REV	DATE	DESCRIPTION	ECO	BY	C'H'K.
B	05/08/2017 00:00:00 AM	LOGO UPDATE	46692	BK	MB

CATALOG NO.	CONDUCTOR		BOLT SIZE	FIG. NO.	DIMENSIONS								INSTALLATION TOOLING (# CRIMPS)														
	CODE (AWG)	NAVY			B ±.06	C ±.04	H REF.	K DIA. ±.02	L ±.09	N ±.04	O.D. ±.01	T REF.	Z MIN.	DIE INDEX	COLOR CODE	MECHANICAL			HYDRAULIC					DIELESS (# CRIMPS)	WIRE STRIP LENGTH		
																MD7-34R MD6	OUR840	Y2MR	BCT500 Y500CT	Y34A	Y750 Y35, BAT35 Y39, BAT750	Y46	Y45				
YAZ25TC516	1/0 AWG. [-----]	100	5/16 [M8]	1	1.38 [35]	.75 [19]	--		2.46 [62]	.34 [9]	.51 [12]	.12 [3]	.36 [9]	12 OR 348	PINK	W25VT W25RT (4)	W25VT W25RT (4)	-----	W25VT W25RT (4)	A25R A2CAB (2)	U25RT U2CABT (2)	U25RT U2CABT (2)	U25RT U2CABT (2)	MECHANICAL: MY29-11(1) HYDRAULIC Y644, Y644M BAT644M Y644MBH, Y1000 Y1000BH (1)	1-7/16		
YAZ25TC51645				2	1.63 [41]		.33 [8]	2.23 [57]																			
YAZ25TC51690				3	1.96 [50]				1.06 [27]																		
YAZ25TC12				1	--				2.84 [72]																		
YAZ25TC1245				2	1.63 [41]		.52 [13]	2.61 [66]		.53 [13]																	
YAZ25TC1290				3	1.38 [35]				1.44 [37]																		

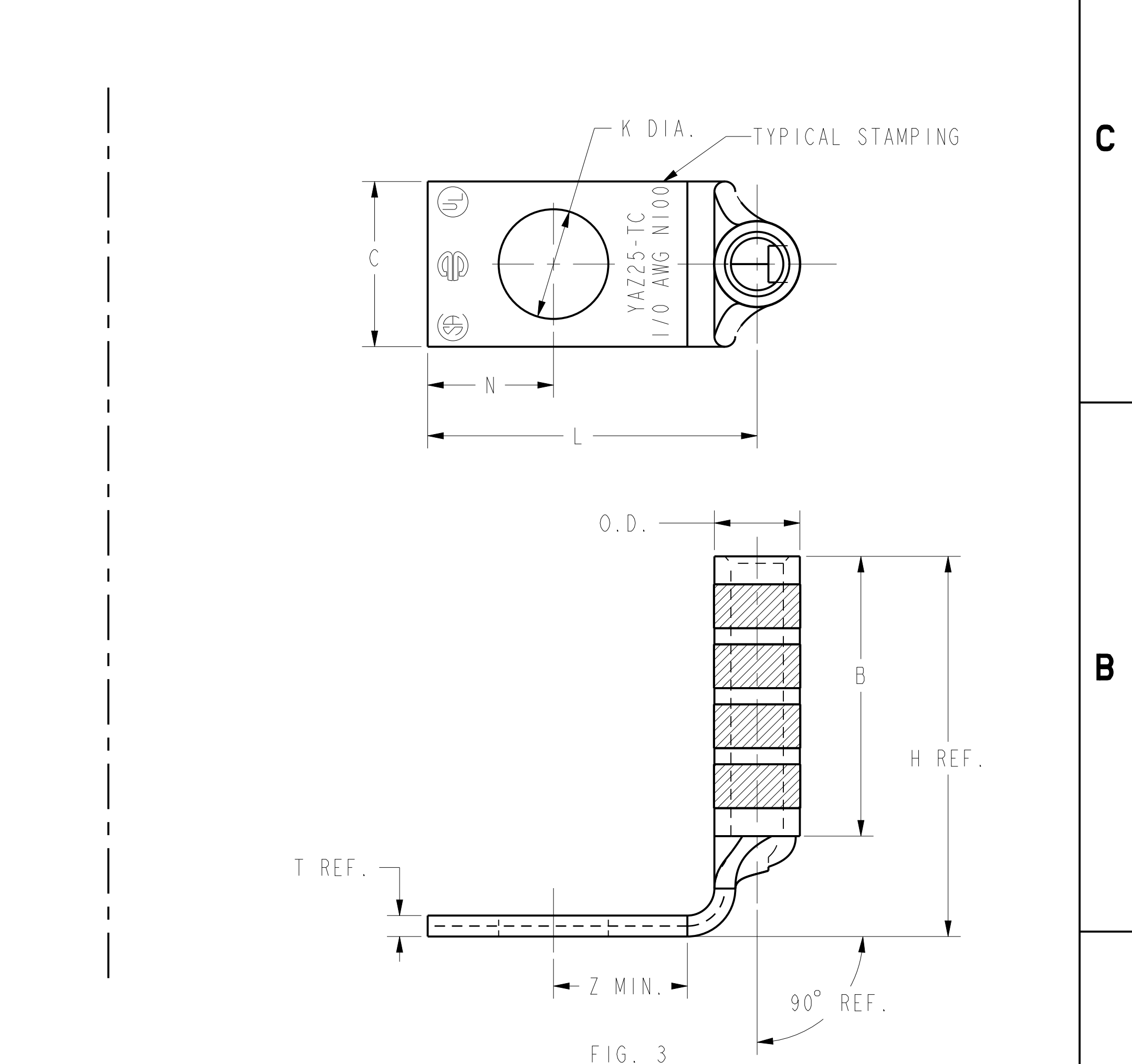
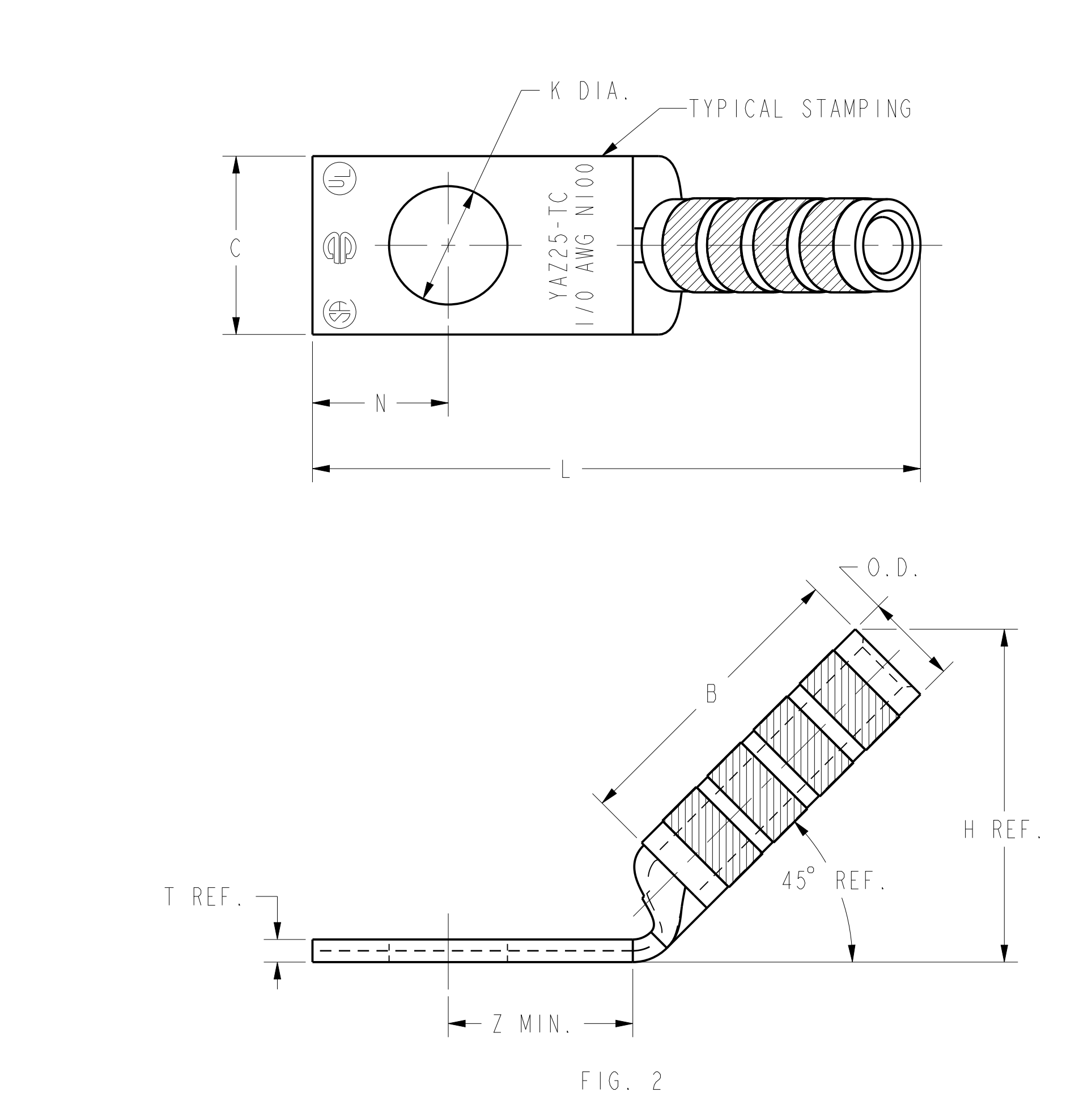
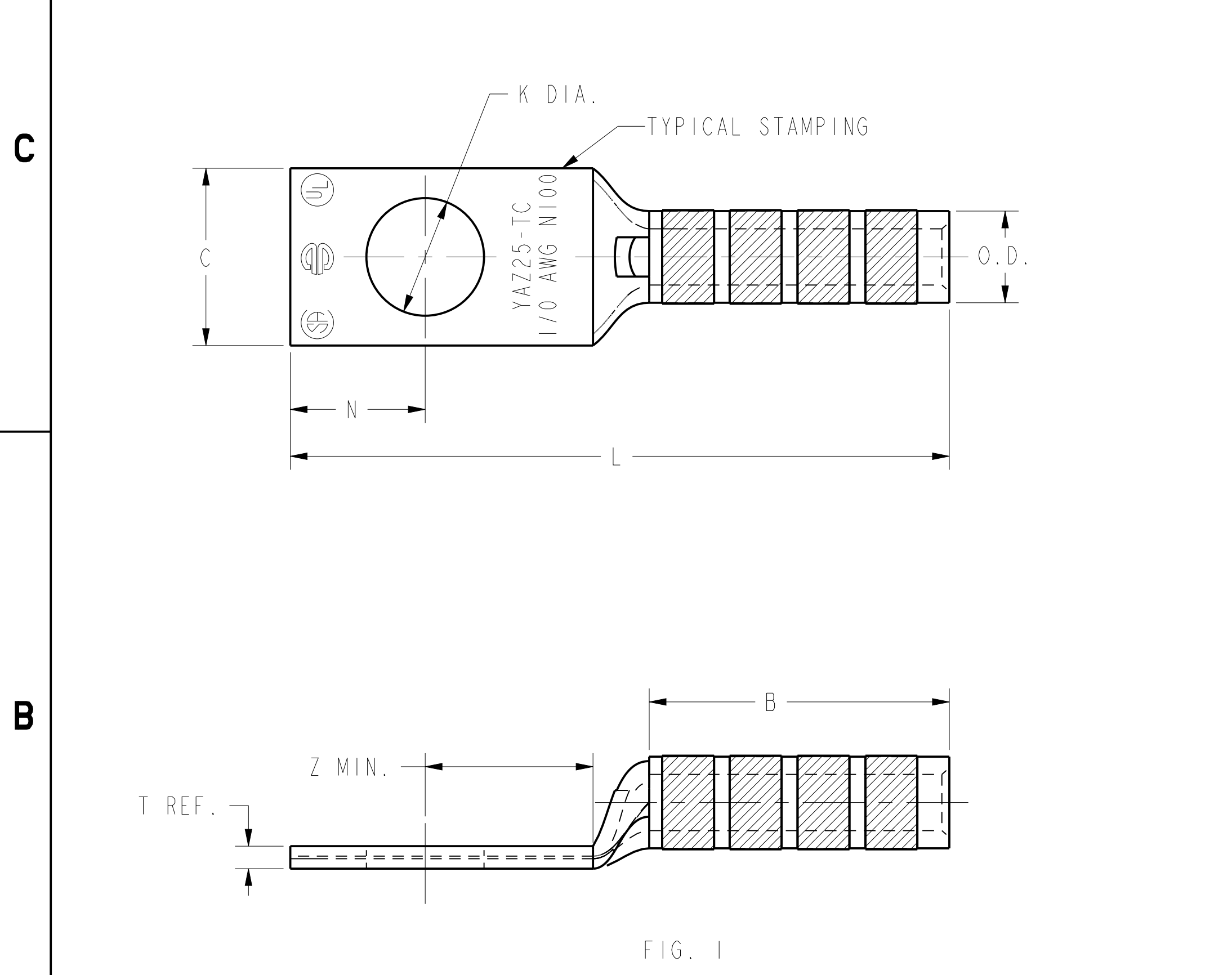

- NOTES:
- MATERIAL: COPPER TUBING.
 - FINISH: TIN PLATED
 - CATALOG # PT6515 ADAPTOR IS REQUIRED TO USE "U" DIES IN Y45 SERIES TOOLS.
 - CATALOG # PUADP-1 ADAPTOR IS REQUIRED TO USE "U" DIES IN Y46 SERIES TOOLS.
 - NAVY CABLE SIZE MAY BE OMITTED ON SOME SIZES BECAUSE OF SPACE LIMITATIONS.
 - PERMANENT DIE IN TOOLING.
 - DIMENSIONS, METRIC WIRE, & METRIC BOLT SIZES IN BRACKETS [] ARE IN MILLIMETERS. DIMENSIONS ARE ROUNDED OFF TO THE NEAREST MILLIMETER, UNLESS OTHERWISE NOTED, AND ARE FOR REFERENCE ONLY.
 - FOR USE BY CUSTOMERS THAT HAVE THIS HYPRESS™. NO NEW Y34A HYPRESS™ TOOLS ARE BEING PROCESSED.

TO ORDER BURNDY® PRODUCTS CALL		HYLUG™ (ONE HOLE CODE)	
UNITED STATES 1-800-346-4175 (LONDONDERRY, NH)		ITEM NO: NA	CAT. NO: YAZ25-TC- (TABLE)
CANADA: 1-800-361-6975 (QUEBEC) 1-800-387-6487 (ALL OTHER PROVINCES)		DRAWN BY: D. BOISVERT 02/03/2000	CHECKER: K. MCCARTHY 04/05/2000
FOR PRODUCT INFO: http://www.burndy.com		DSN APPVL: J.MICHAUD 05/04/2000	MFG APPVL: N/A
		GA APPVL: S.BROWN	MKT APPVL: N/A
		PROD FAM: --	DRAWING NO: SE212356
		PROJECT #: --	SIZE: D
		DOCUMENT TYPE: Sales	SHEET 16 OF 40
		REL LEVEL: Released	REV: B