

REV	DATE	DESCRIPTION	ECO	BY	CHK.
B	05/08/2017 00:00:00 AM	LOGO UPDATE	46692	BK	MB

CATALOG NO.	CONDUCTOR		BOLT SIZE	FIG. NO.	DIMENSIONS									INSTALLATION TOOLING (# CRIMPS)										
	CODE (AWG)	NAVY			B ±.08	C ±.04	H REF.	K DIA. ±.02	L ±.12	N ±.04	O.D. ±.01	T REF.	Z MIN.	DIE INDEX	COLOR CODE	MECHANICAL			HYDRAULIC				DIELESS (# CRIMPS)	WIRE STRIP LENGTH
																MD7-34R MD6	OUR840	Y2MR	BCT500 Y500CT	Y34A	Y750 Y35, BAT35 Y39, BAT750	Y46		
YAZ26TC14	2/0 AWG. [70mm ² STR]	125	1	1	1.50 [38]	.83 [21]	--	2.56 [65]	.31 [8]	.56 [14]	.12 [3]	.33 [8]	13	BLACK	W26VT	W26VT	-----	W26VT	A26R (2)	U26RT (2)	U26RT (2)	U26RT (2)	MECHANICAL: MY29-11(1) HYDRAULIC Y644, Y644M BAT644M Y644MBH, Y1000 Y1000BH (1)	1-9/16
YAZ26TC1445															W26RT (4)	W26RT (4)	-----	W26RT (4)	A26R (2)	U26RT (2)	U26RT (2)	U26RT (2)		
YAZ26TC1490															W26VT	W26VT	-----	W26VT	A26R (2)	U26RT (2)	U26RT (2)	U26RT (2)		
YAZ26TC38	2/0 AWG. [70mm ² STR]	125	1	1	1.50 [38]	.83 [21]	--	2.75 [70]	.41 [10]	.56 [14]	.12 [3]	.42 [11]	13	BLACK	W26VT	W26VT	-----	W26VT	A26R (2)	U26RT (2)	U26RT (2)	U26RT (2)	MECHANICAL: MY29-11(1) HYDRAULIC Y644, Y644M BAT644M Y644MBH, Y1000 Y1000BH (1)	1-9/16
YAZ26TC3845															W26RT (4)	W26RT (4)	-----	W26RT (4)	A26R (2)	U26RT (2)	U26RT (2)	U26RT (2)		
YAZ26TC3890															W26VT	W26VT	-----	W26VT	A26R (2)	U26RT (2)	U26RT (2)	U26RT (2)		

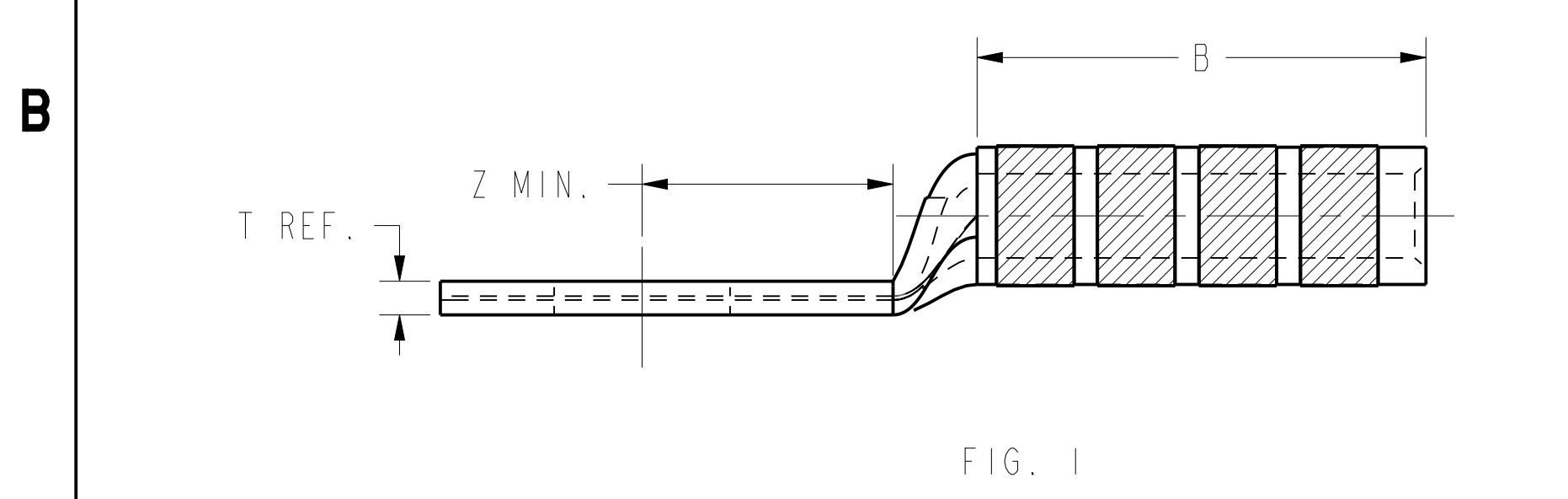
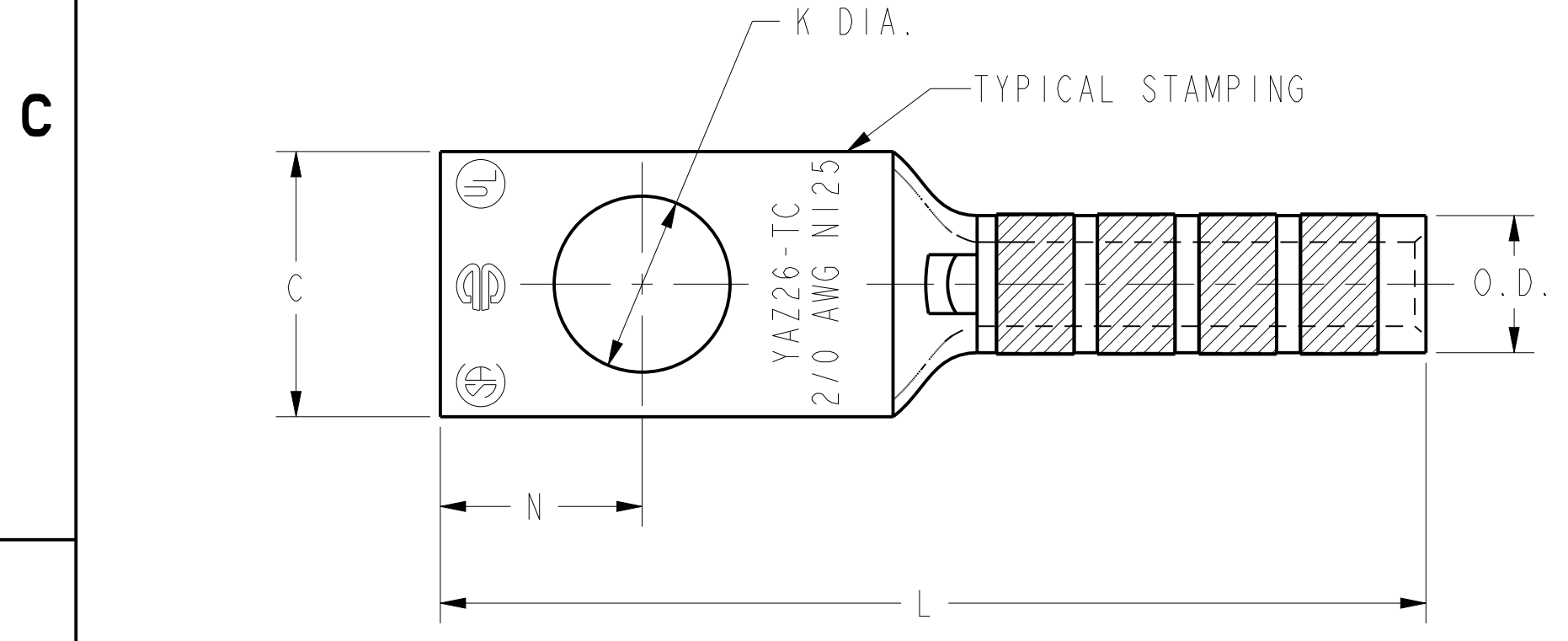

FIG. 1

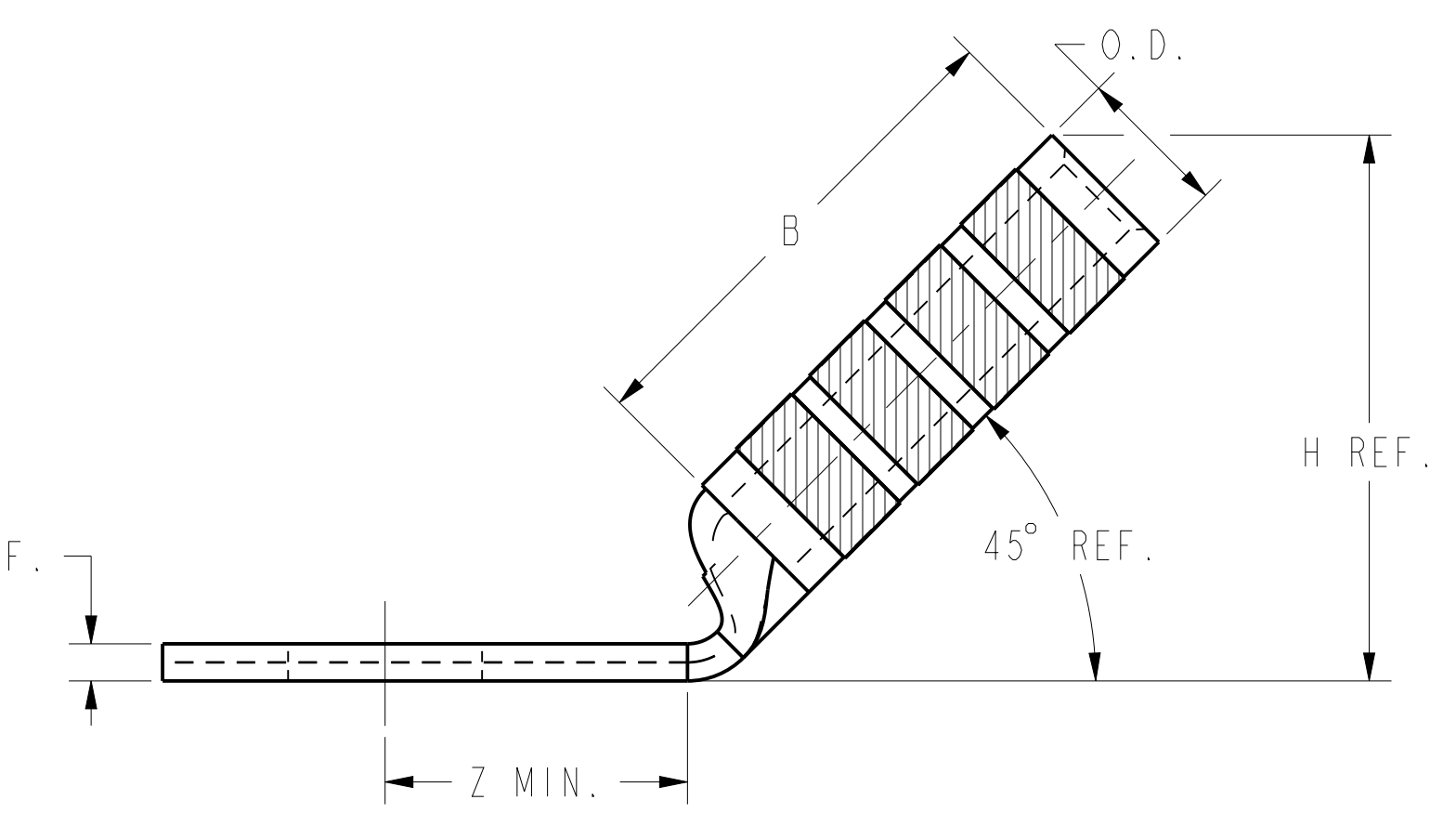
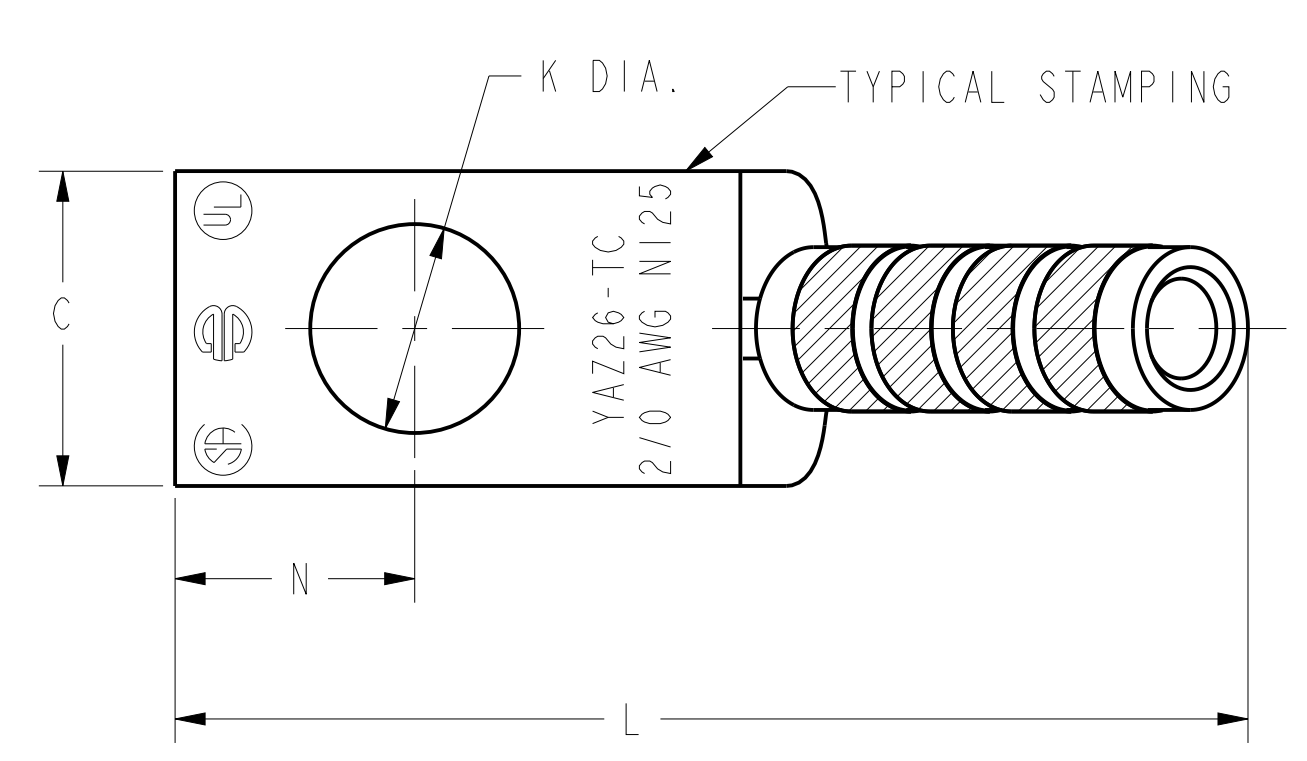

FIG. 2

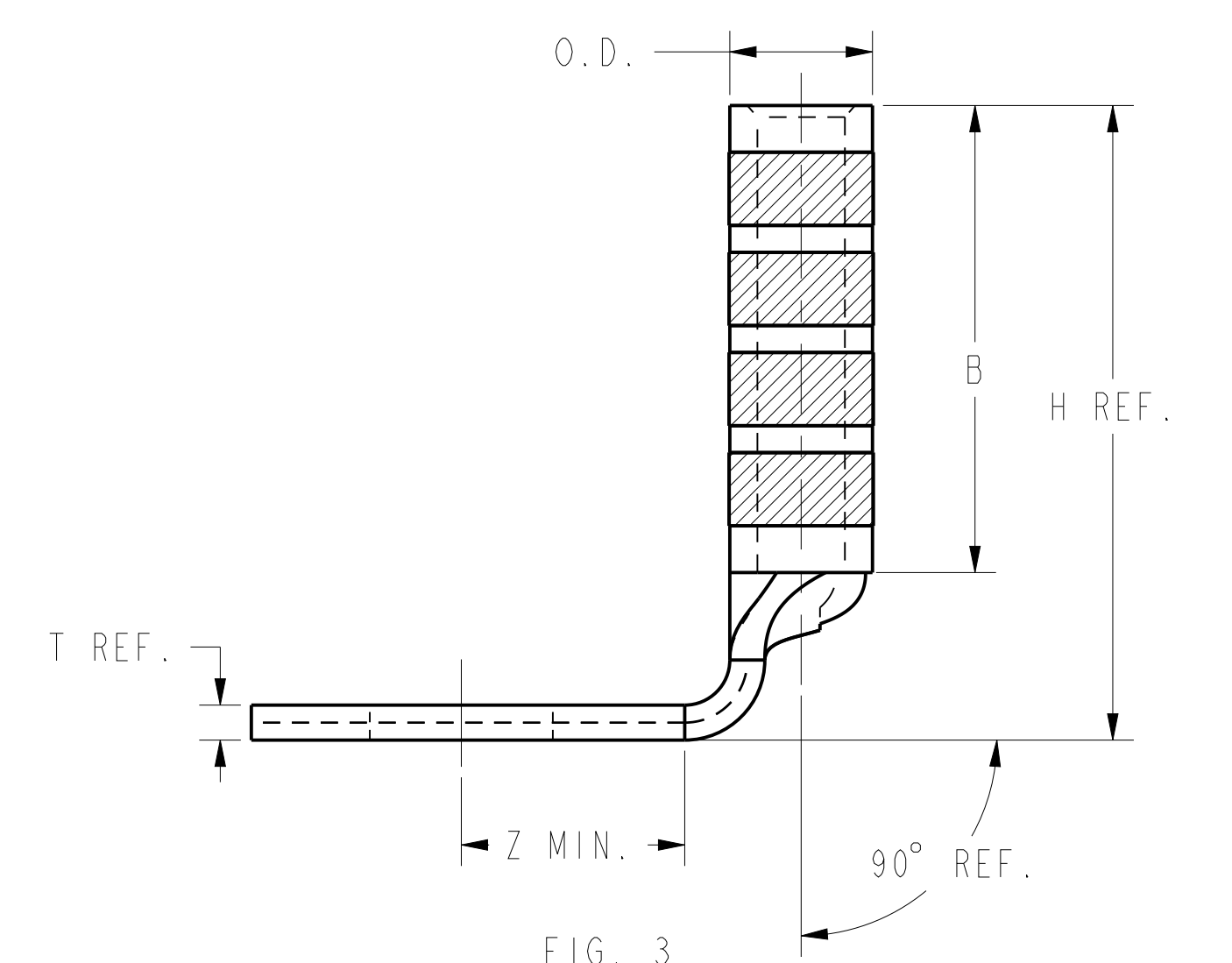
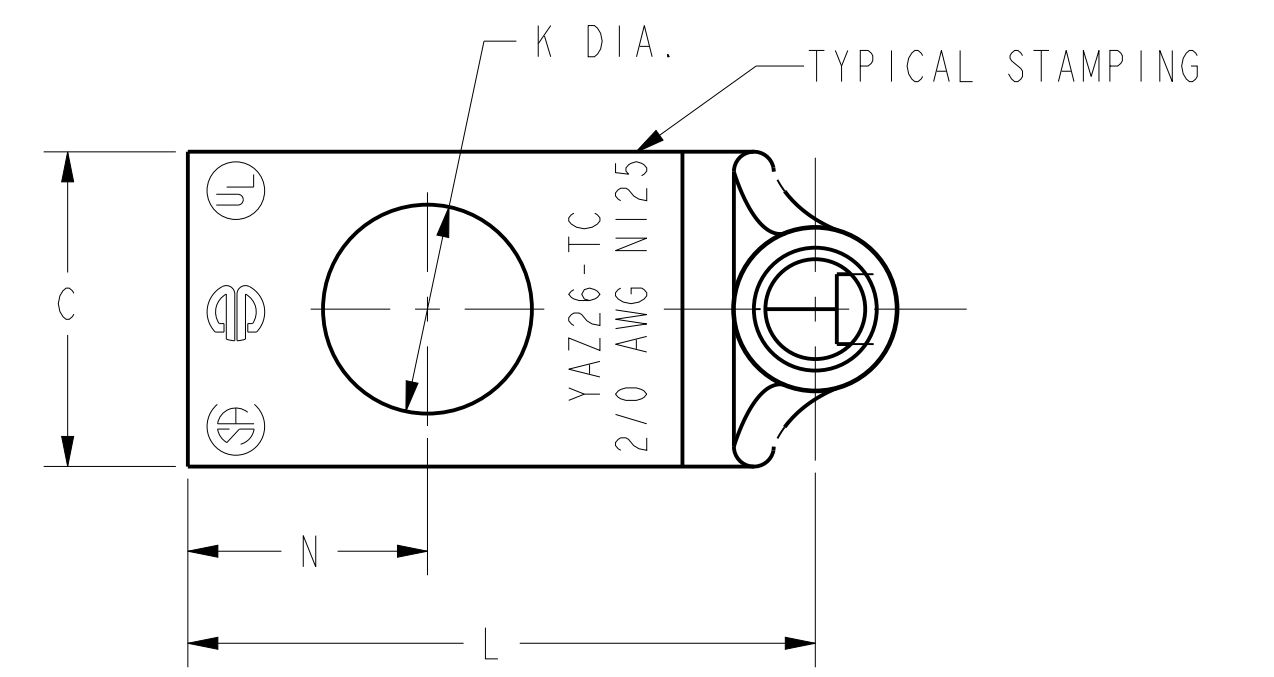

FIG. 3

- NOTES:
1. MATERIAL: COPPER TUBING.
 2. FINISH: TIN PLATED
 3. CATALOG # PT6515 ADAPTOR IS REQUIRED TO USE "U" DIES IN Y45 SERIES TOOLS.
 4. CATALOG # PUADP-1 ADAPTOR IS REQUIRED TO USE "U" DIES IN Y46 SERIES TOOLS.
 5. NAVY CABLE SIZE MAY BE OMITTED ON SOME SIZES BECAUSE OF SPACE LIMITATIONS.
 6. PERMANENT DIE IN TOOLING.
 7. DIMENSIONS, METRIC WIRE, & METRIC BOLT SIZES IN BRACKETS [] ARE IN MILLIMETERS. DIMENSIONS ARE ROUNDED OFF TO THE NEAREST MILLIMETER, UNLESS OTHERWISE NOTED, AND ARE FOR REFERENCE ONLY.
 8. FOR USE BY CUSTOMERS THAT HAVE THIS HYPRESS™. NO NEW Y34A HYPRESS™ TOOLS ARE BEING PROCESSED.

TO ORDER BURNDY® PRODUCTS CALL		HYLUG™ (ONE HOLE CODE)	
UNITED STATES 1-800-346-4175 (LONDONDERRY, NH)		ITEM NO: NA	CAT. NO: YAZ26-TC- (TABLE)
CANADA: 1-800-361-6975 (QUEBEC) 1-800-387-6487 (ALL OTHER PROVINCES)		DRAWN BY: D. BOISVERT 02/03/2000	CHECKER: K. MCCARTHY 04/05/2000
FOR PRODUCT INFO: http://www.burndy.com		DSN APPVL: J. MICHARD 05/04/2000	MFG APPVL: N/A
		QA APPVL: S. BROWN	MKT APPVL: N/A
		PROD FAM: --	SCALE: NTS
		PROJECT #: --	DRAWING NO: SE212356
		DOCUMENT TYPE: Sales	REV: B
		REL LEVEL: Released	SHEET 17 OF 40

REV: PE0200