

REV	DATE	DESCRIPTION	ECO	BY	C'H'K.
B	05/08/2017 00:00:00 AM	LOGO UPDATE	46692	BK	MB

CATALOG NO.	CONDUCTOR		BOLT SIZE	FIG. NO.	DIMENSIONS								INSTALLATION TOOLING (# CRIMPS)															
	CODE (AWG)	NAVY			B	C	H	K DIA.	L	N	O.D.	T	Z	DIE INDEX	COLOR CODE	MECHANICAL			HYDRAULIC				DIELESS (# CRIMPS)	WIRE STRIP LENGTH				
					±.08	±.04	REF.	±.02	±.12	±.04	±.01	REF.	MIN.			MD7-34R MD6	OUR840	Y2MR	BCT500 Y500CT	Y34A	Y750 Y35, BAT35 Y39, BAT750	Y46			Y45			
YAZ27TC38	3/0 AWG. [-----]	150	3/8 [M10]	1	1.50 [38]	.90 [23]	--		2.79 [71]		.62 [16]	.12 [3]	.42 [11]	14	ORANGE	W27VT	W27VT	-----	W27VT	A27R (2)	U27RT (2)	U27RT (2)	U27RT (2)	MECHANICAL: MY29-11(1) HYDRAULIC Y644, Y644M BAT644M Y644MBH, Y1000 Y1000BH (1)	1-9/16			
YAZ27TC3845				2	1.84 [47]		.40 [10]	2.51 [64]	.41 [10]			W27RT (4)				W27RT (4)		W27RT (4)										
YAZ27TC3890				3	2.16 [55]			1.24 [31]																				
YAZ27TC12	3/0 AWG. [-----]	150	1/2 [M12]	1			--		3.04 [77]				.55 [14]	14	ORANGE	W27VT	W27VT	-----	W27VT	A27R (2)	U27RT (2)	U27RT (2)	U27RT (2)		1-9/16			
YAZ27TC1245				2	1.84 [47]		.52 [13]	2.76 [70]	.53 [13]			W27RT (4)				W27RT (4)		W27RT (4)										
YAZ27TC1290				3	1.50 [38]			2.16 [55]			1.49 [38]																	

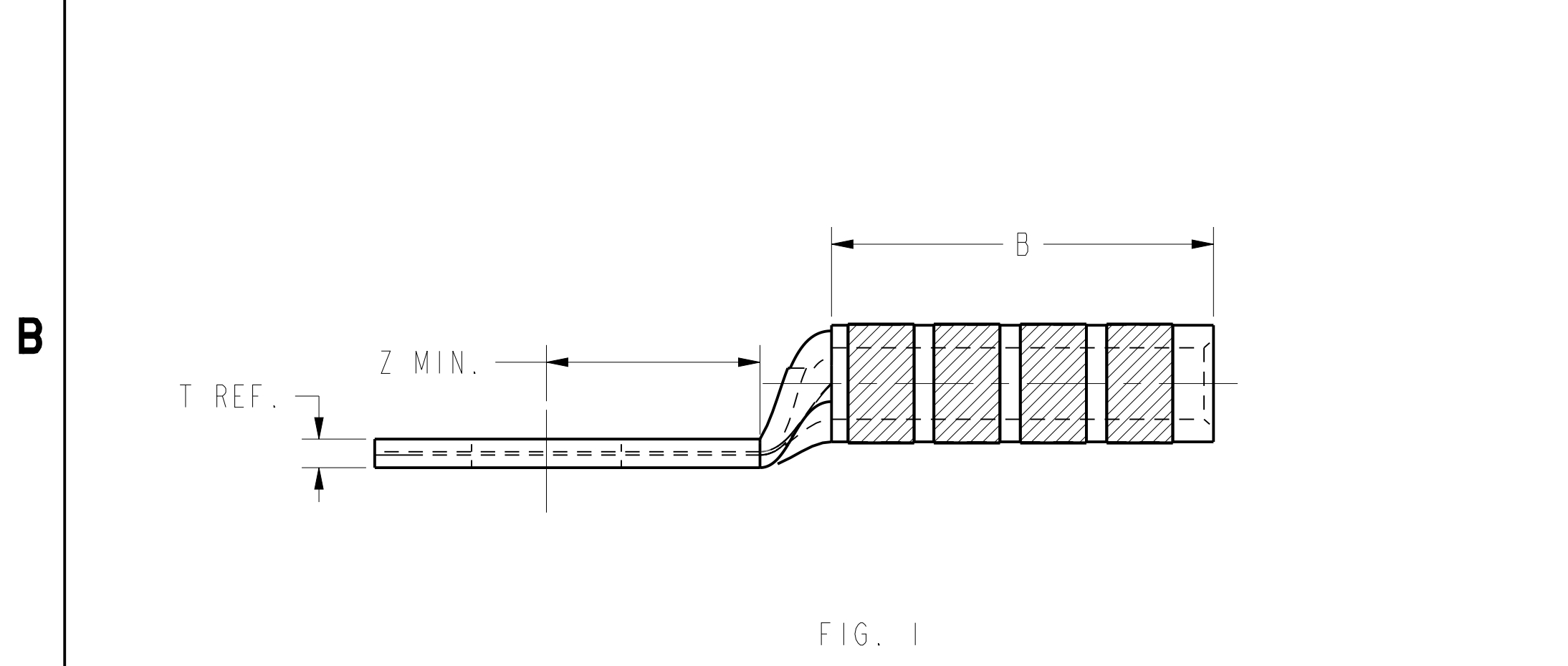
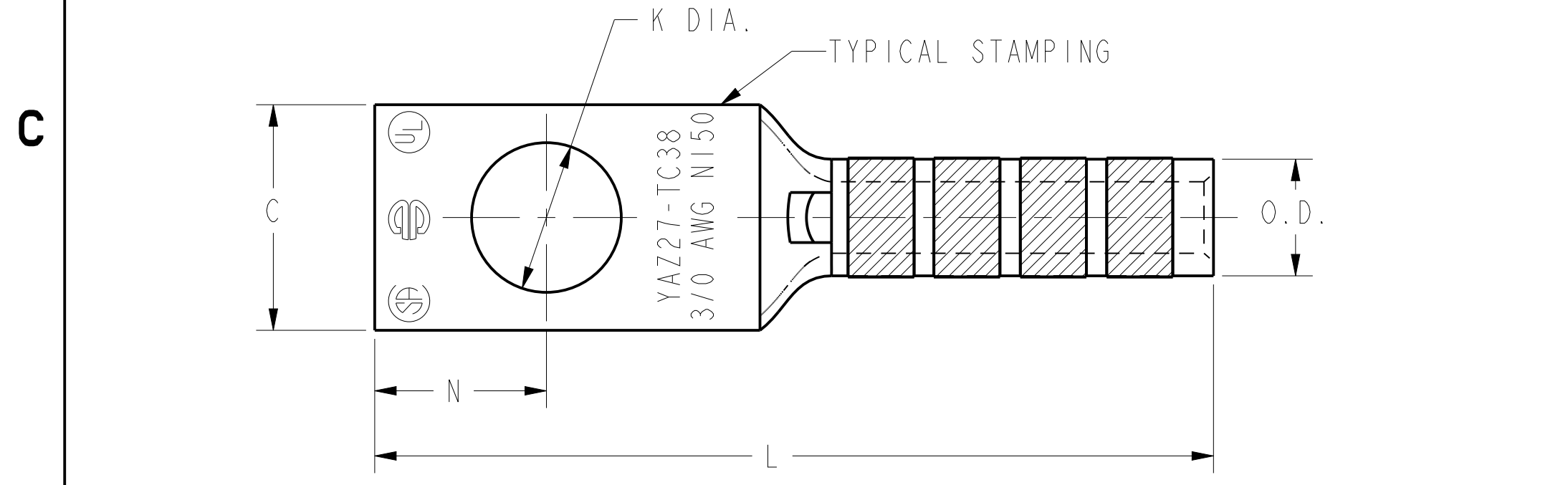

FIG. 1

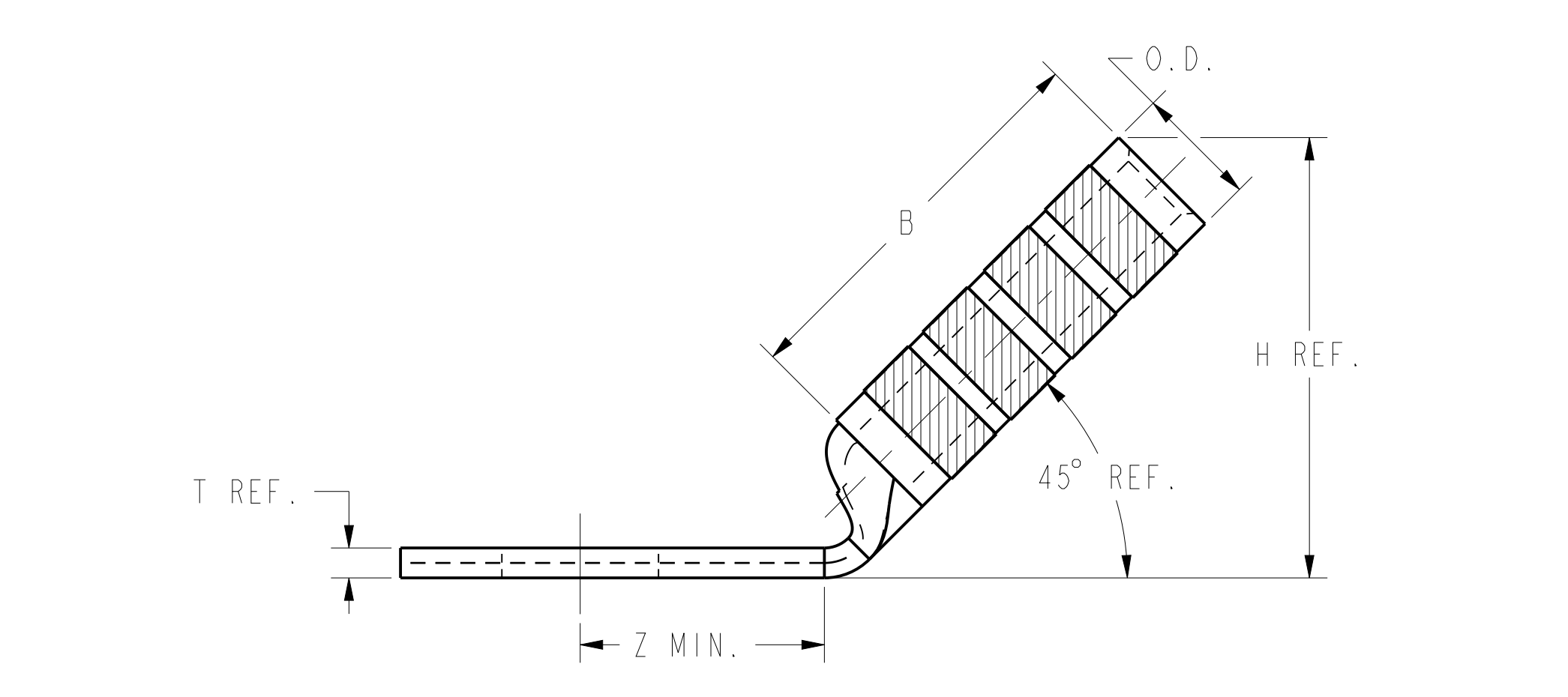
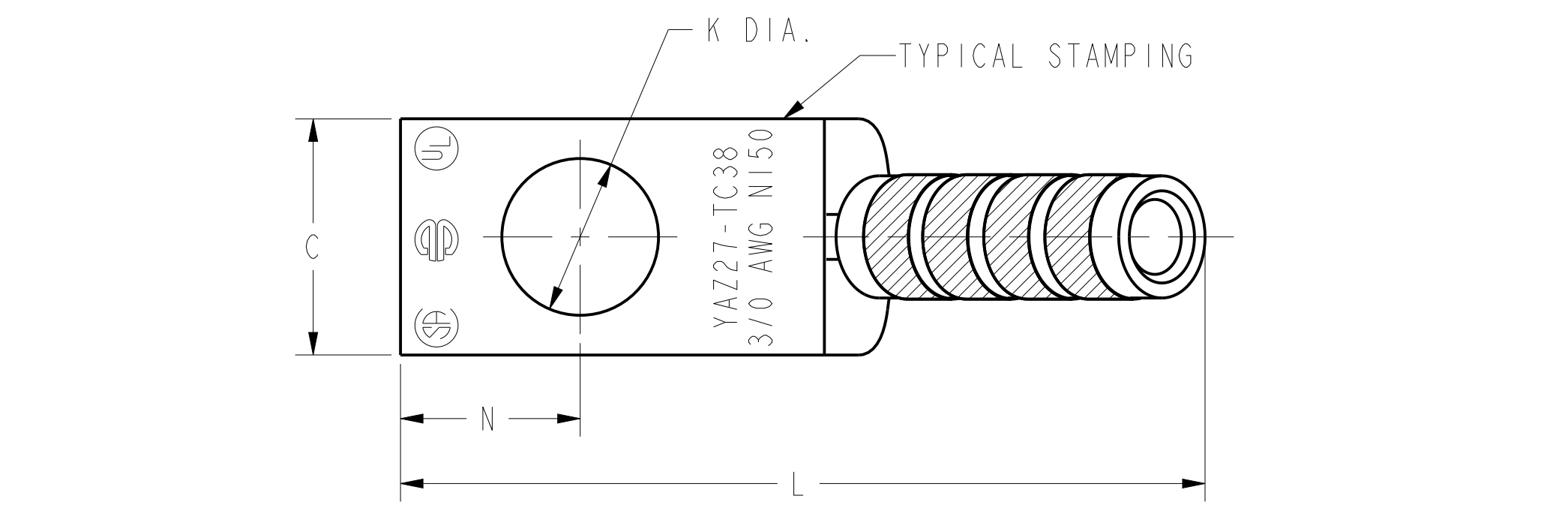

FIG. 2

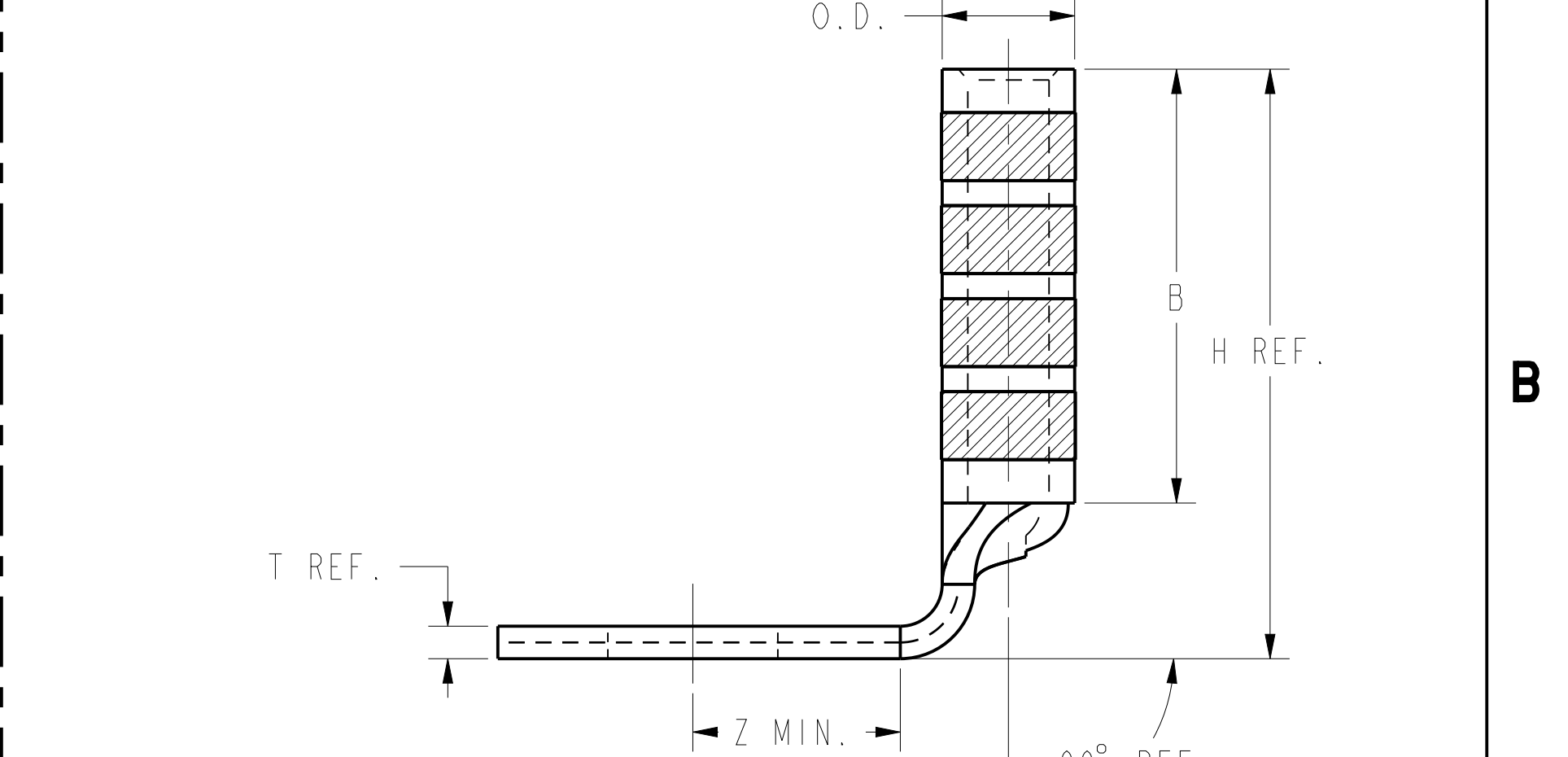
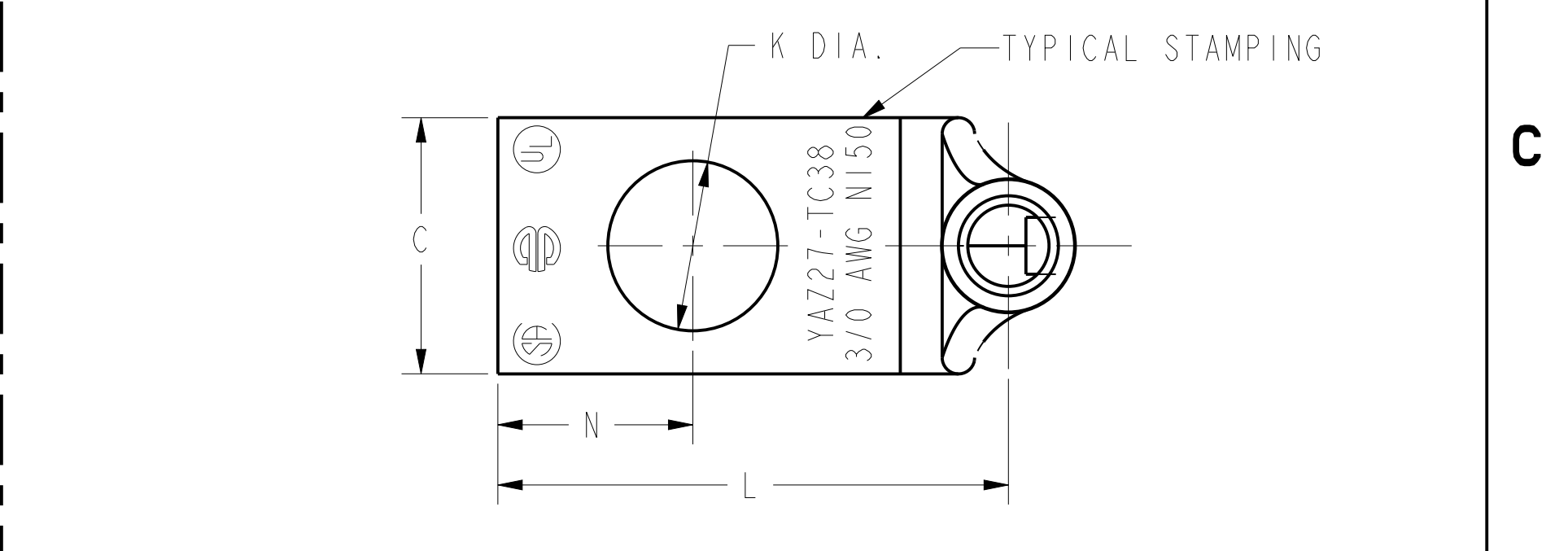

FIG. 3

- NOTES:
- MATERIAL: COPPER TUBING.
 - FINISH: TIN PLATED
 - CATALOG # PT6515 ADAPTOR IS REQUIRED TO USE "U" DIES IN Y45 SERIES TOOLS.
 - CATALOG # PUADP-1 ADAPTOR IS REQUIRED TO USE "U" DIES IN Y46 SERIES TOOLS.
 - NAVY CABLE SIZE MAY BE OMITTED ON SOME SIZES BECAUSE OF SPACE LIMITATIONS.
 - PERMANENT DIE IN TOOLING.
 - DIMENSIONS, METRIC WIRE, & METRIC BOLT SIZES IN BRACKETS [] ARE IN MILLIMETERS. DIMENSIONS ARE ROUNDED OFF TO THE NEAREST MILLIMETER, UNLESS OTHERWISE NOTED, AND ARE FOR REFERENCE ONLY.
 - FOR USE BY CUSTOMERS THAT HAVE THIS HYPRESS™. NO NEW Y34A HYPRESS™ TOOLS ARE BEING PROCESSED.

TO ORDER BURNDY® PRODUCTS CALL		HYLUG™ (ONE HOLE CODE)	
UNITED STATES 1-800-346-4175 (LONDONDERRY, NH)		ITEM NO: NA	CAT. NO: YAZ27-TC- (TABLE)
CANADA: 1-800-361-6975 (QUEBEC) 1-800-387-6487 (ALL OTHER PROVINCES)		DRAWN BY: D.BOISVERT 02/03/2000	CHECKER: K.MCCARTHY 04/05/2000
FOR PRODUCT INFO: http://www.burndy.com		DSN APPVL: J.MICHAUD 05/04/2000	MFG APPVL: N/A
		QA APPVL: S.BROWN	MKT APPVL: N/A
		PROD FAM: --	SCALE: NTS
		PROJECT #: --	DRAWING NO
		DOCUMENT TYPE: Sales	REV
		REL LEVEL: Released	SIZE
			SE212356
			SHEET 19 OF 40
			B

REV: PEO200