



REV	DATE	DESCRIPTION	ECO	BY	C'H'K.
B	05/08/2017 00:00:00 AM	LOGO UPDATE	46692	BK	MB

CATALOG NO.	CONDUCTOR		BOLT SIZE	FIG. NO.	DIMENSIONS								INSTALLATION TOOLING (# CRIMPS)															
	CODE (AWG)	NAVY 			B ±.08	C ±.04	H REF.	K DIA. ±.02	L ±.12	N ±.04	O.D. ±.01	T REF.	Z MIN.	DIE INDEX	COLOR CODE	MECHANICAL		HYDRAULIC							DIELESS (# CRIMPS)	WIRE STRIP LENGTH		
																MD7-34R MD6	OUR840	BCT500 Y500CT	Y34A 	Y750 Y35, BAT35 Y39, BAT750	Y46 	Y45 	Y48B 	Y60B				
YAZ29TC38	250 kcmil [120mm ² STR]	250		1	1.62 [41]	1.10 [28]	--		2.98 [76]			.75 [19]	.16 [4]			16	YELLOW	W29VT W29RT (4)	X29RT (6)		A29R (2)	U29RT (2)	U29RT (2)	U29RT (2)	C29R (2)	L29RT (1)		1-11/16
YAZ29TC3845				2			2.09 [53]	.40 [10]	2.72 [69]	.41 [10]																		
YAZ29TC3890				3			2.42 [61]		1.32 [34]																			
YAZ29TC12				1			--		3.23 [82]																			
YAZ29TC1245			1/2 [M12]	2			2.09 [53]	.52 [13]	2.97 [75]	.53 [13]																		
YAZ29TC1290	250 kcmil [120mm ² STR]	250		3	1.62 [41]	1.10 [28]	2.42 [61]		1.58 [40]			.75 [19]	.16 [4]			16	YELLOW	W29VT W29RT (4)	X29RT (6)		A29R (2)	U29RT (2)	U29RT (2)	U29RT (2)	C29R (2)	L29RT (1)		1-11/16

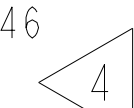
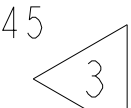
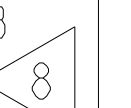
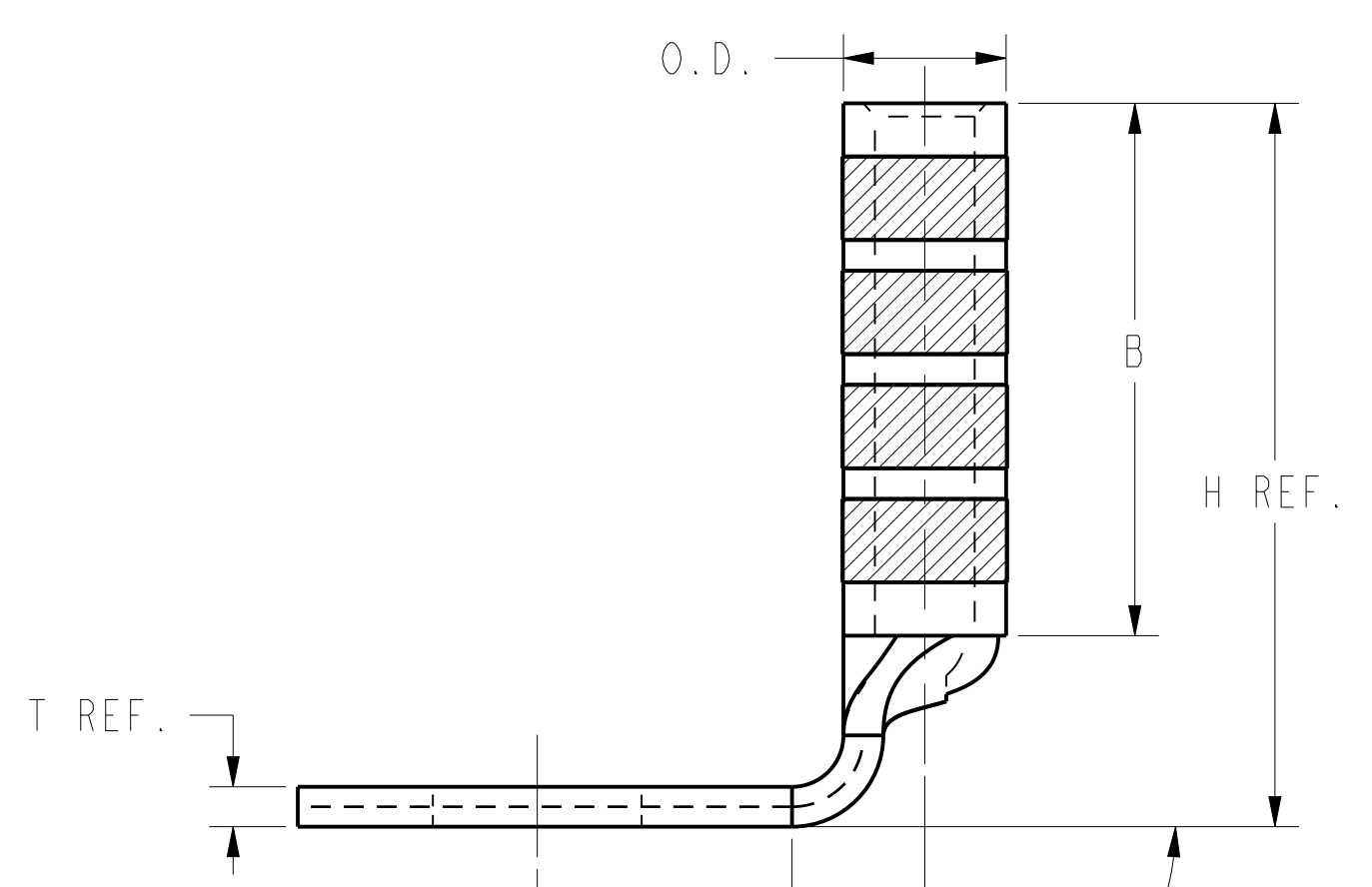
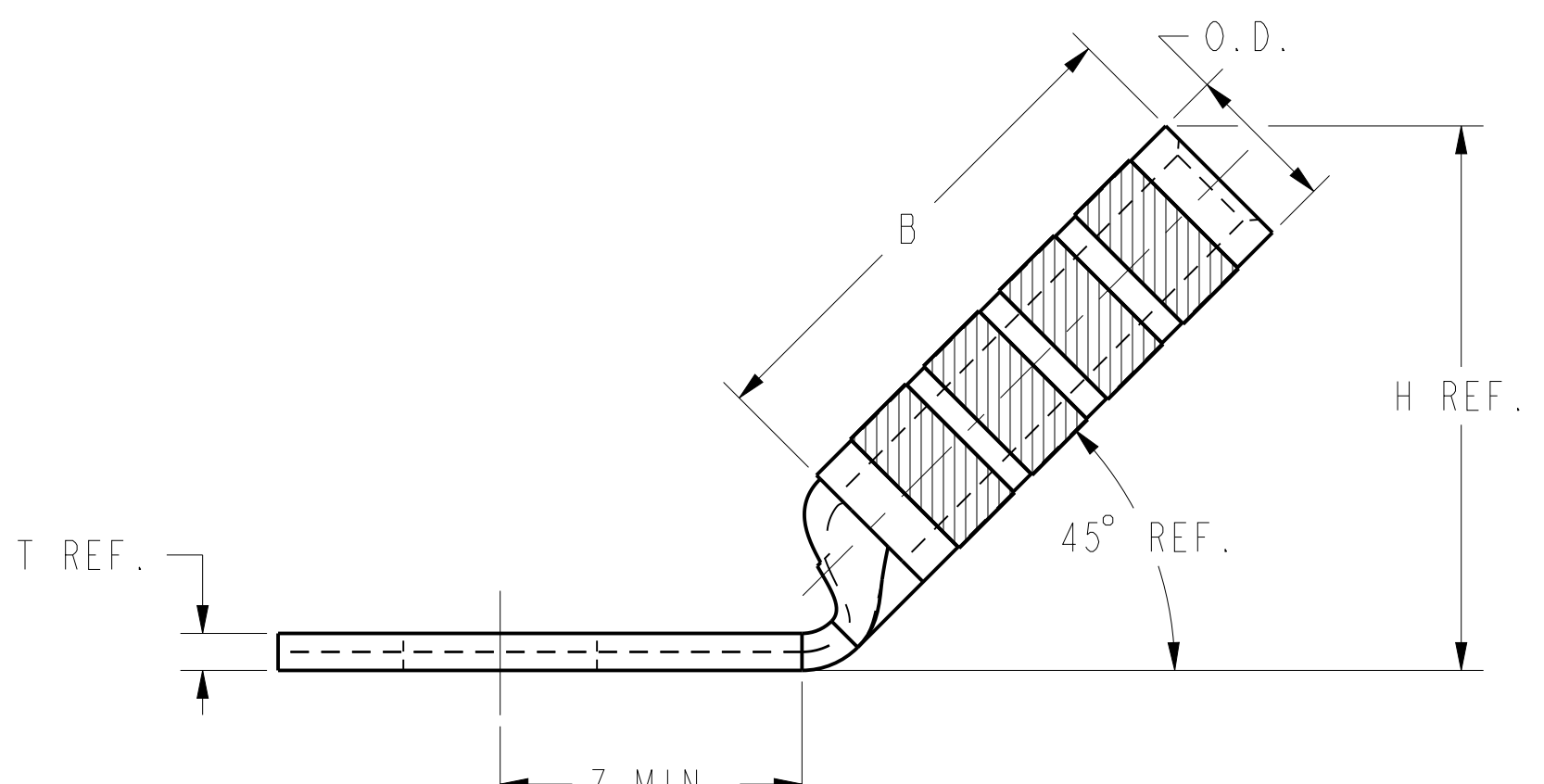
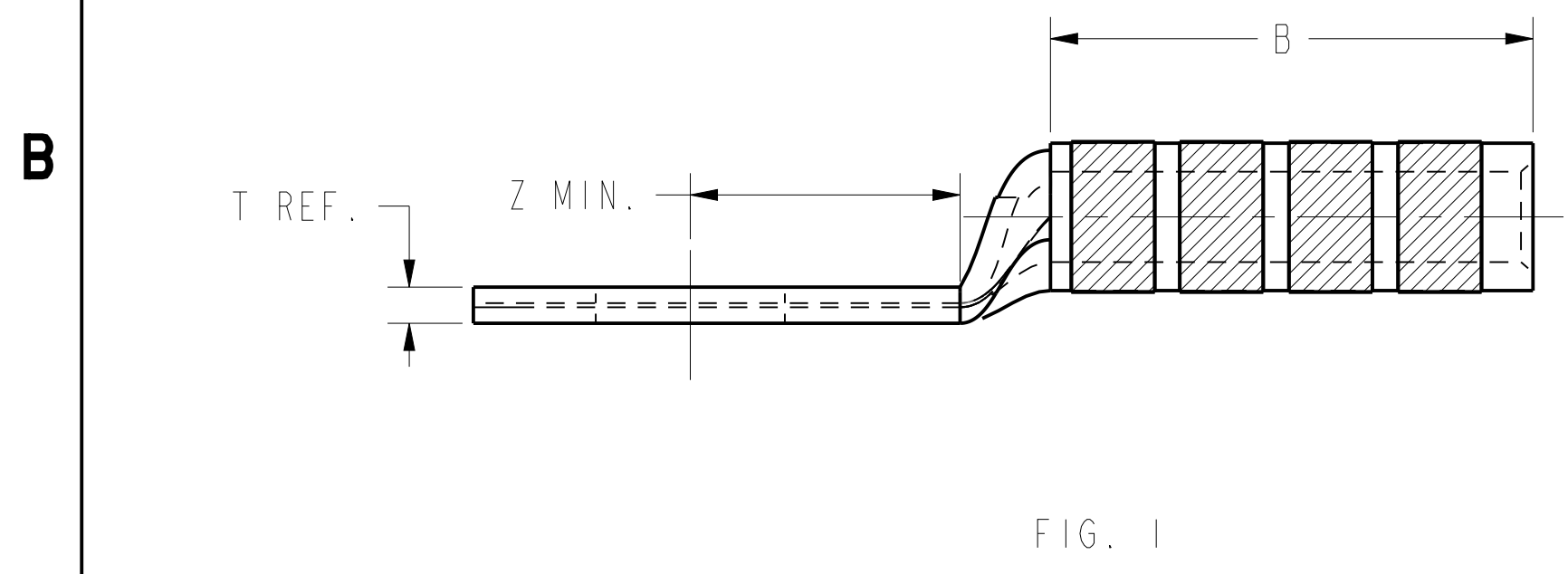
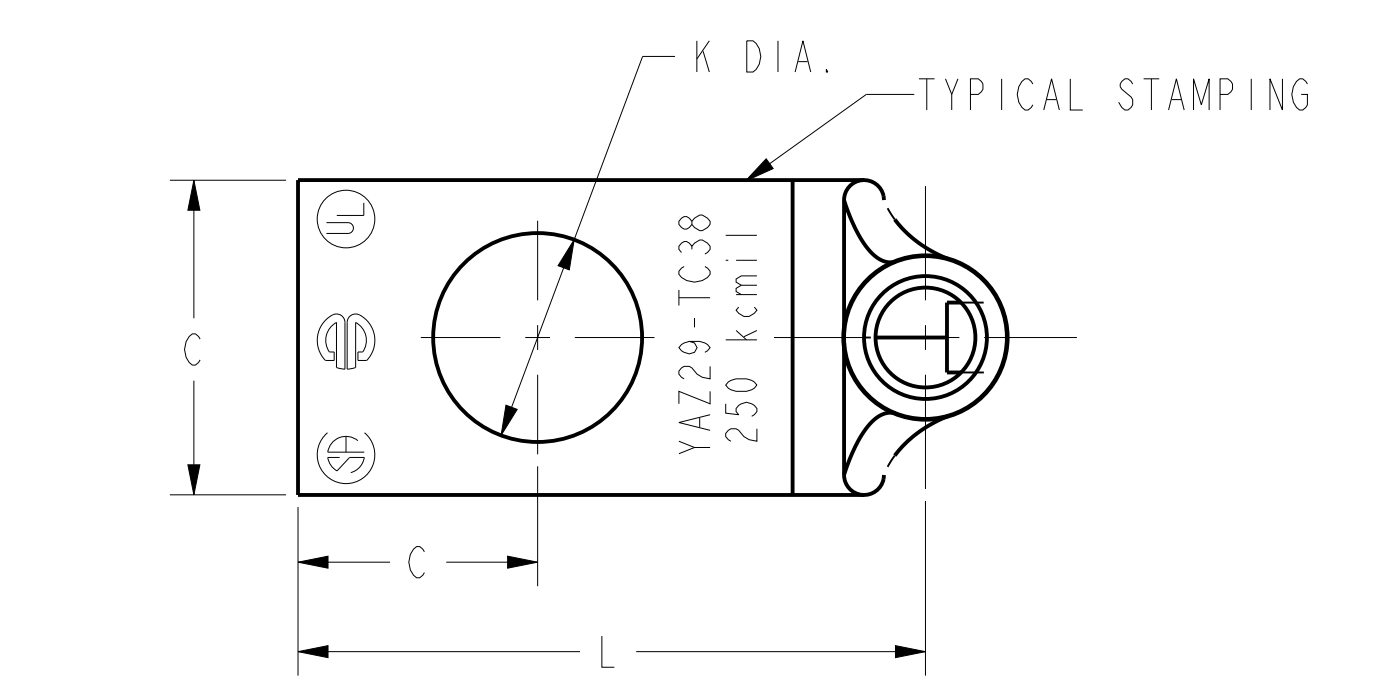
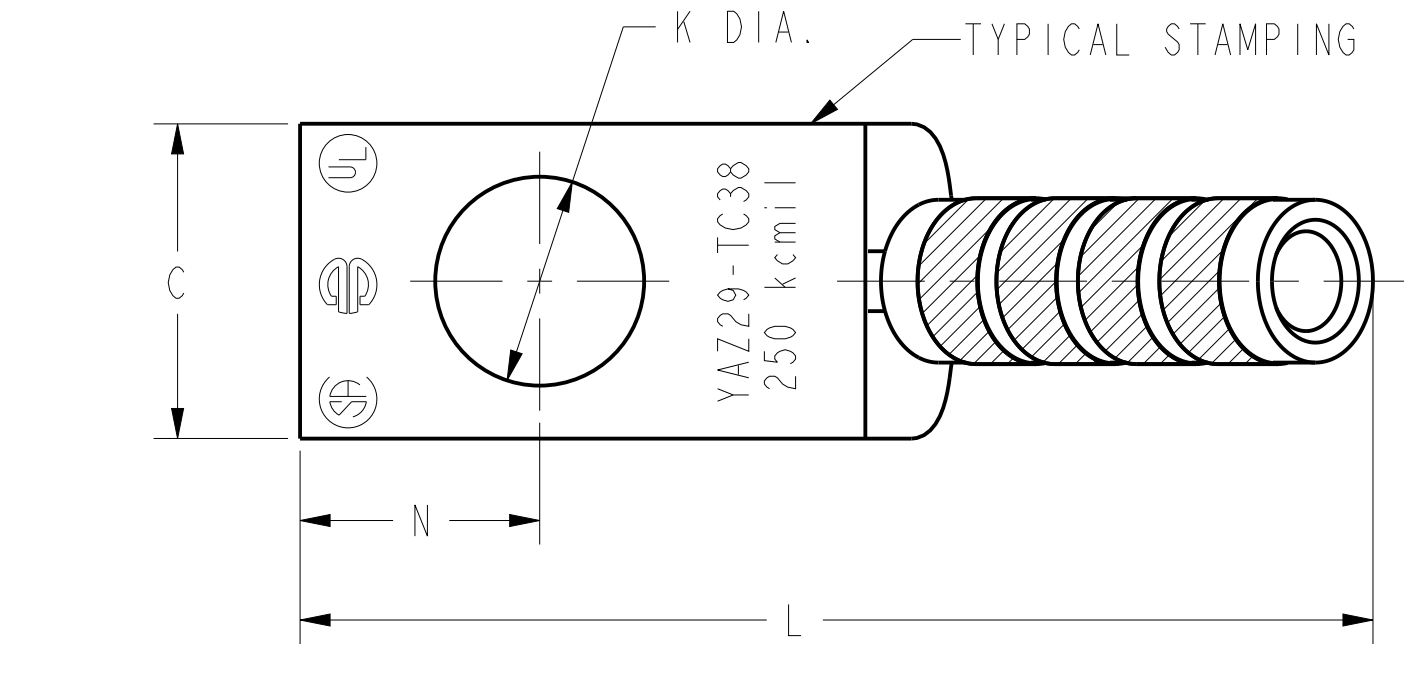
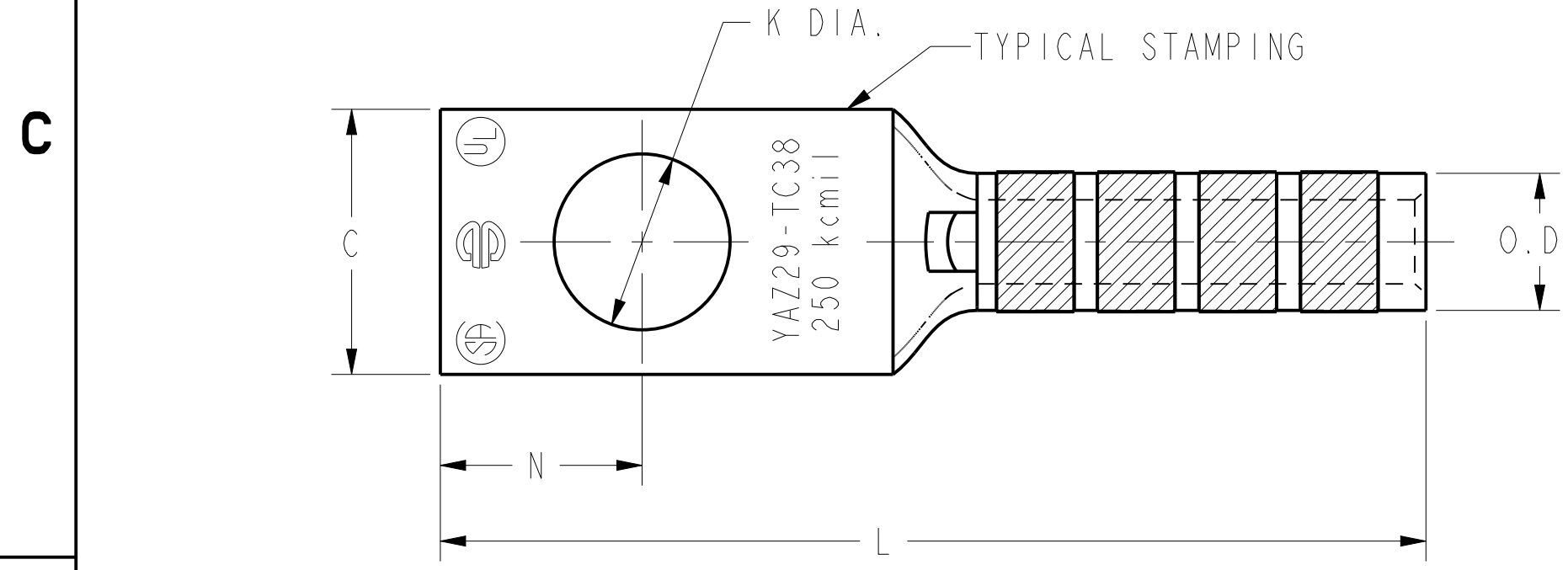

- NOTES:
- MATERIAL: COPPER TUBING.
 - FINISH: TIN PLATED
 - CATALOG # PT6515 ADAPTOR IS REQUIRED TO USE "U" DIES IN Y45 SERIES TOOLS.
 - CATALOG # PUADP-1 ADAPTOR IS REQUIRED TO USE "U" DIES IN Y46 SERIES TOOLS.
 - NAVY CABLE SIZE MAY BE OMITTED ON SOME SIZES BECAUSE OF SPACE LIMITATIONS.
 - FOR USE BY CUSTOMERS THAT HAVE THIS HYPRESS™. NO NEW Y34A HYPRESS™ TOOLS ARE BEING PROCESSED.
 - DIMENSIONS, METRIC WIRE, & METRIC BOLT SIZES IN BRACKETS [] ARE IN MILLIMETERS. DIMENSIONS ARE ROUNDED OFF TO THE NEAREST MILLIMETER, UNLESS OTHERWISE NOTED, AND ARE FOR REFERENCE ONLY.
 - OVERLAPPING CRIMPS ARE REQUIRED ON THESE SIZES.

TO ORDER BURNDY® PRODUCTS CALL		HYLUG™ (ONE HOLE CODE)	
UNITED STATES 1-800-346-4175 (LONDONDERRY, NH)		ITEM NO: NA	CAT. NO: YAZ29-TC- (TABLE)
CANADA: 1-800-361-6975 (QUEBEC) 1-800-387-6487 (ALL OTHER PROVINCES)		DRAWN BY: D. BOISVERT 02/03/2000	CHECKER: R. BOISVERT 01/10/2001
FOR PRODUCT INFO: http://www.burndy.com		DSN APPVL: J.MICHAUD 05/04/2000	MFG APPVL: N/A
		GA APPVL: S.BROWN	MKT APPVL: N/A
		PROD FAM: --	DRAWING NO: REV
		PROJECT #: --	SIZE: SE212356
		DOCUMENT TYPE: Sales	SHEET 21 OF 40
		REL LEVEL: Released	B