

REV	DATE	DESCRIPTION	ECO	BY	C.H.K.
B	05/08/2017 00:00:00 AM	LOGO UPDATE	46692	BK	MB

CATALOG NO.	CONDUCTOR		BOLT SIZE	FIG. NO.	DIMENSIONS									INSTALLATION TOOLING (# CRIMPS)																	
														DIE INDEX	COLOR CODE	HYDRAULIC					DIELESS (# CRIMPS)	WIRE STRIP LENGTH									
	Y750 Y35, BAT35 Y39, BAT750	Y46 4			Y45 3	Y48B	Y60B	Y644, Y644M BAT644M Y644MBH, Y1000 Y1000BH (1)																							
YAZ37TC12	650 kcmil [-----]	---	1/2 [M12]	1	B ±.09	C ±.06	H REF.	K DIA. ±.02	L ±.15	N ±.06	O.D. ±.01	T REF.	Z MIN.	23	ORANGE	U37RT (4)	U37RT (4)	U37RT (2)	C37R (2)	L37RT (2)	HYDRAULIC: Y644, Y644M BAT644M Y644MBH, Y1000 Y1000BH (1)	2-7/8									
YAZ37TC1245				2																			2.81 [71]	1.80 [46]	3.54 [90]	.52 [13]	4.31 [109]	.53 [13]	1.23 [31]	.27 [7]	.55 [14]
YAZ37TC1290				3																					4.15 [105]		1.89 [48]				

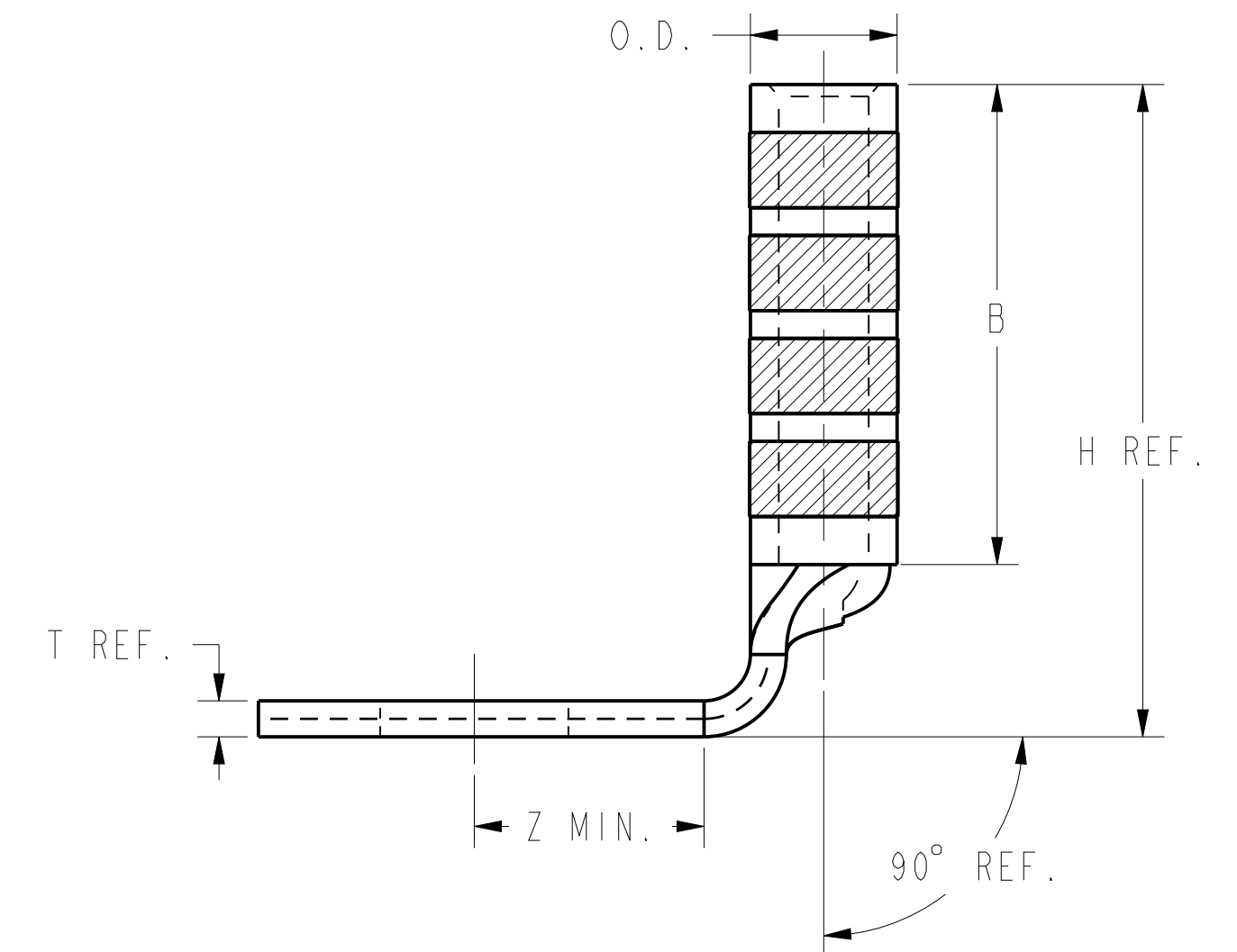
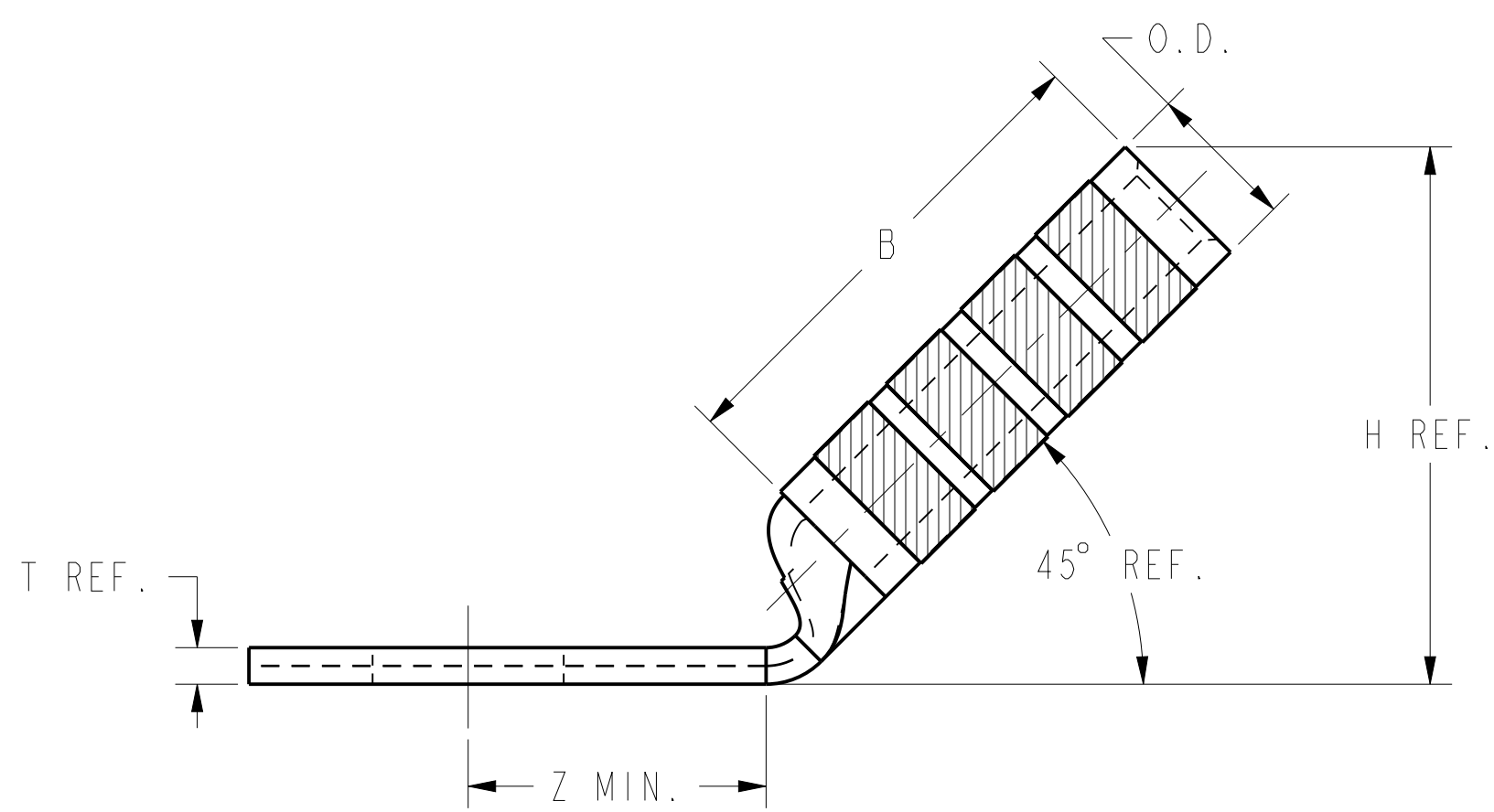
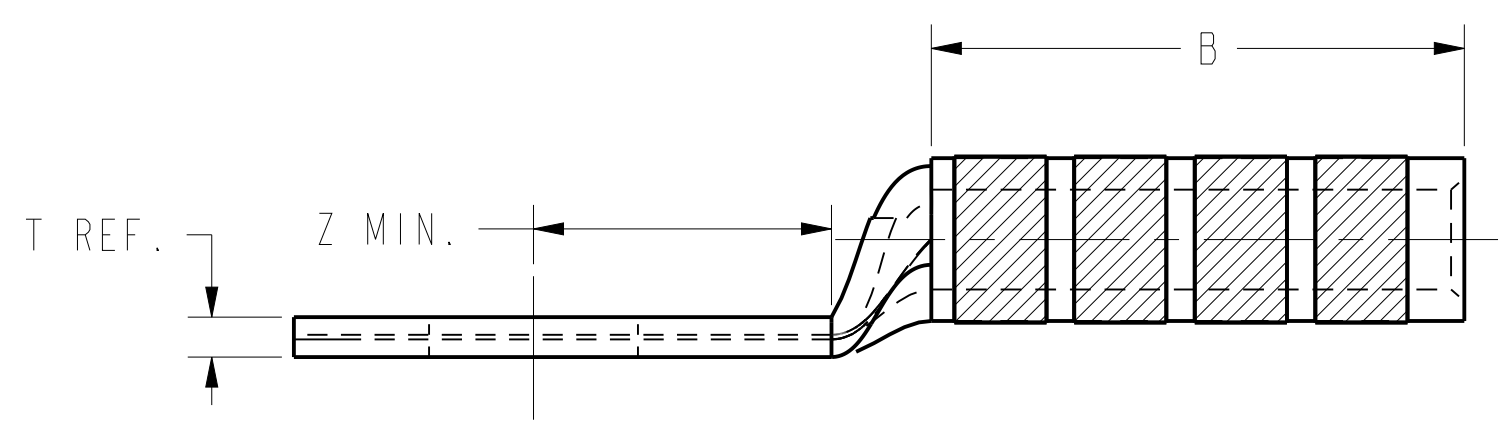
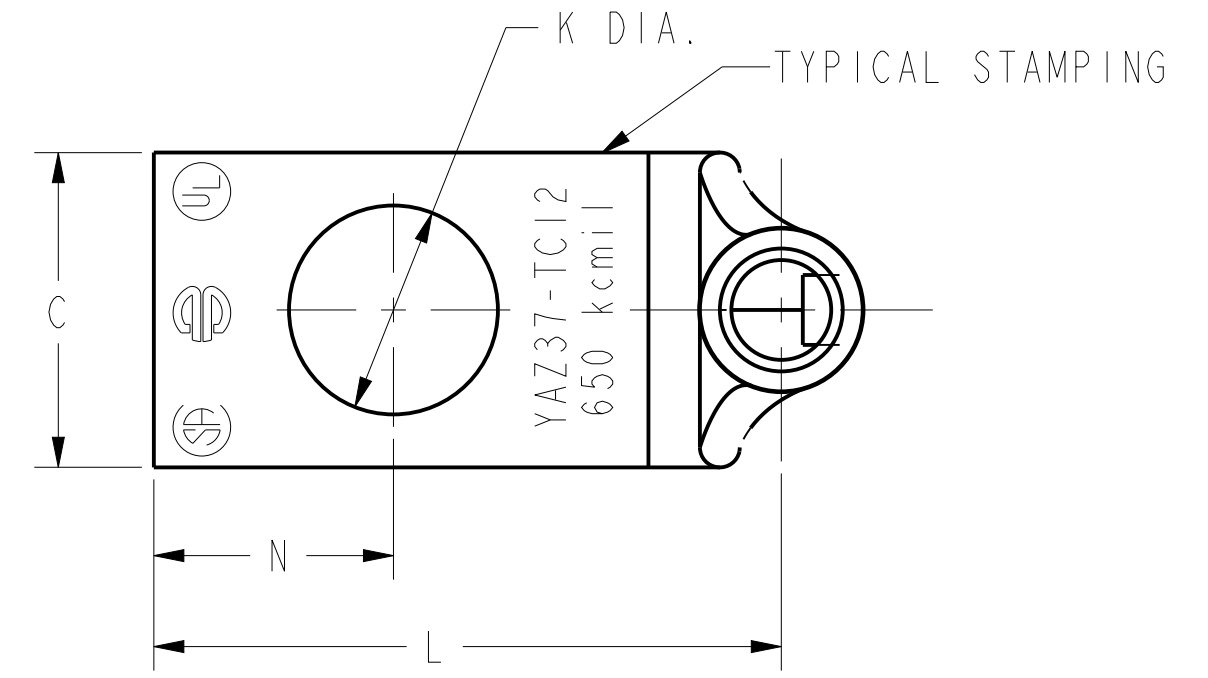
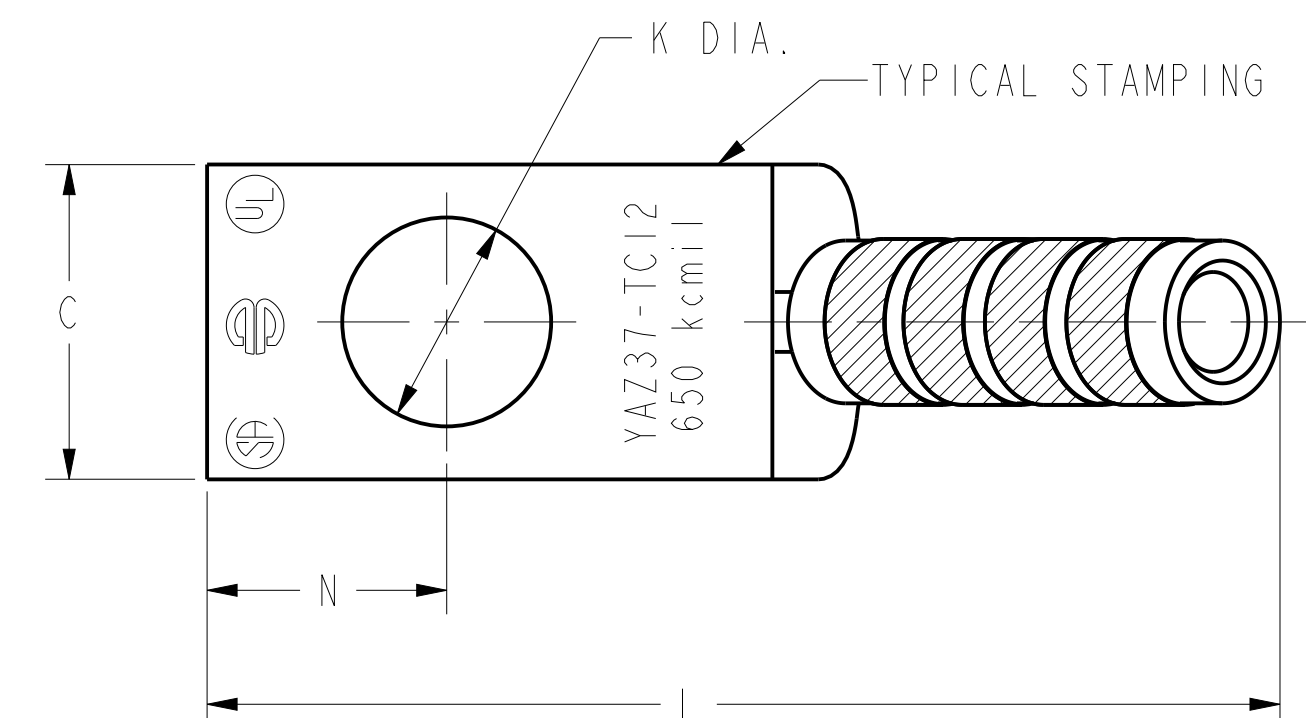
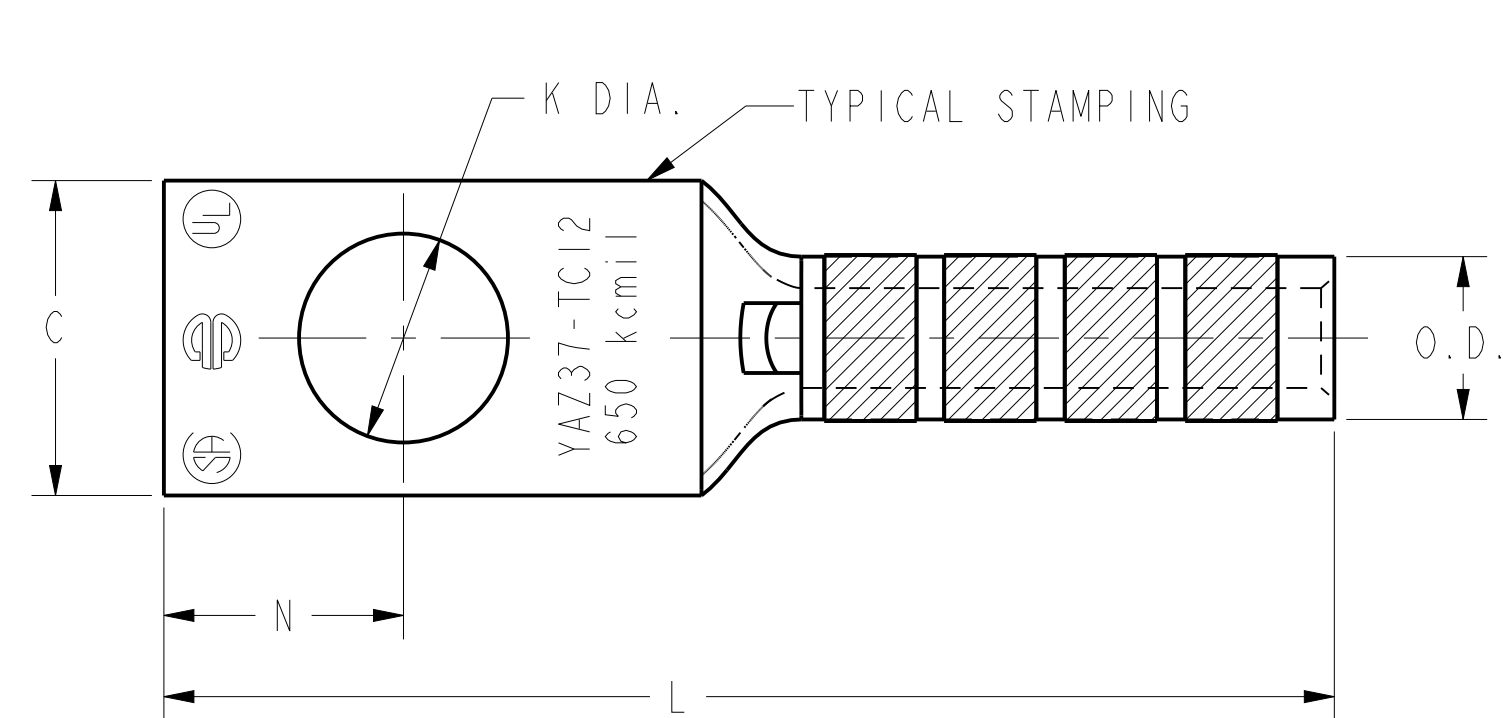

FIG. 1

FIG. 2

FIG. 3

NOTES:

- MATERIAL: COPPER TUBING.
- FINISH: TIN PLATED
- CATALOG # PT6515 ADAPTOR IS REQUIRED TO USE "U" DIES IN Y45 SERIES TOOLS.
- CATALOG # PUADP-1 ADAPTOR IS REQUIRED TO USE "U" DIES IN Y46 SERIES TOOLS.
- DIMENSIONS, METRIC WIRE, & METRIC BOLT SIZES IN BRACKETS [ ] ARE IN MILLIMETERS. DIMENSIONS ARE ROUNDED OFF TO THE NEAREST MILLIMETER, UNLESS OTHERWISE NOTED, AND ARE FOR REFERENCE ONLY.

TO ORDER BURNDY® PRODUCTS CALL		HYLUG™ (ONE HOLE CODE)	
UNITED STATES 1-800-346-4175 (LONDONDERRY, NH)		ITEM NO: NA	CAT. NO: YAZ37-TC- (TABLE)
CANADA: 1-800-361-6975 (QUEBEC) 1-800-387-6487 (ALL OTHER PROVINCES)		DRAWN BY: D. BOISVERT 02/03/2000	CHECKER: K. MCCARTHY 04/05/2000
FOR PRODUCT INFO: <a href="http://www.burndy.com">http://www.burndy.com</a>		DSN APPVL: J. MICHAUD 05/04/2000	MFG APPVL: N/A
		QA APPVL: S. BROWN	MKT APPVL: N/A
		PROD FAM: --	DRAWING NO: REV
		PROJECT #: --	SIZE: SE212356
		DOCUMENT TYPE: Sales	SHEET 29 OF 40
		REL LEVEL: Released	B

REV: PE0200

