

REV	DATE	DESCRIPTION	ECO	BY	C.H.K.
B	05/08/2017 00:00:00 AM	LOGO UPDATE	46692	BK	MB

CATALOG NO.	CONDUCTOR		BOLT SIZE	FIG. NO.	DIMENSIONS								INSTALLATION TOOLING (# CRIMPS)									
	CODE (AWG)	NAVY			B ±.09	C ±.06	H REF.	K DIA. ±.02	L ±.15	N ±.06	O.D. ±.01	T REF.	Z MIN.	DIE INDEX	COLOR CODE	HYDRAULIC					DIELESS (# CRIMPS)	WIRE STRIP LENGTH
																Y750 Y35, BAT35 Y39, BAT750	Y46 4	Y45 3	Y48B	Y60B		
YAZ39TC38	750 kcmil [-----]	---	1	2.88 [73]	1.91 [49]	--		4.81 [122]		1.30 [33]	.27 [7]		24	BLACK	U39RT (4)	U39RT (4)	U39RT (4)	C39R (2)	L39RT (2)	HYDRAULIC: Y644, Y644M BAT644M Y644MBH, Y1000 Y1000BH (1)	2-15/16	
YAZ39TC3845			2			3.68 [93]	.40 [10]	4.33 [110]	.50 [13]													
YAZ39TC3890			3			4.27 [108]		1.86 [47]														
YAZ39TC12			1			--	.52 [13]	4.87 [124]	.53 [13]		.55 [14]											
YAZ39TC1245			2			3.68 [93]		4.39 [112]														
YAZ39TC1290			3			1.91 [49]	4.27 [108]	1.92 [49]														
YAZ39NT12			1			--		4.87 [124]														
YAZ39NT1245			2			3.68 [93]		4.39 [112]														
YAZ39NT1290	750 kcmil [-----]	---	3	2.88 [73]	1.63 [41]	4.27 [108]	.52 [13]	1.92 [49]	.53 [13]	1.30 [33]	.27 [7]	.55 [14]	24	BLACK	U39RT (4)	U39RT (4)	U39RT (4)	C39R (2)	L39RT (2)		2-15/16	

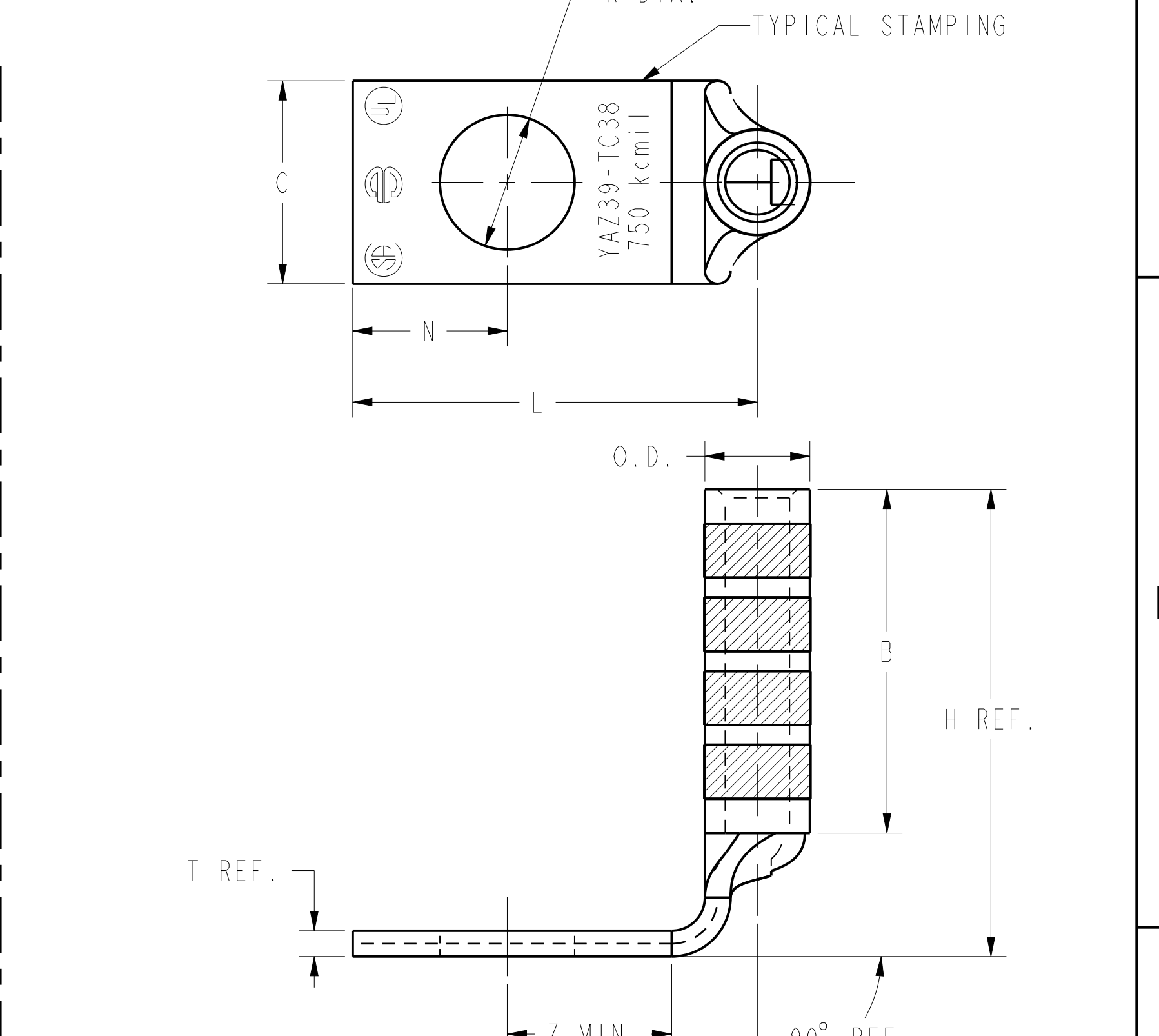
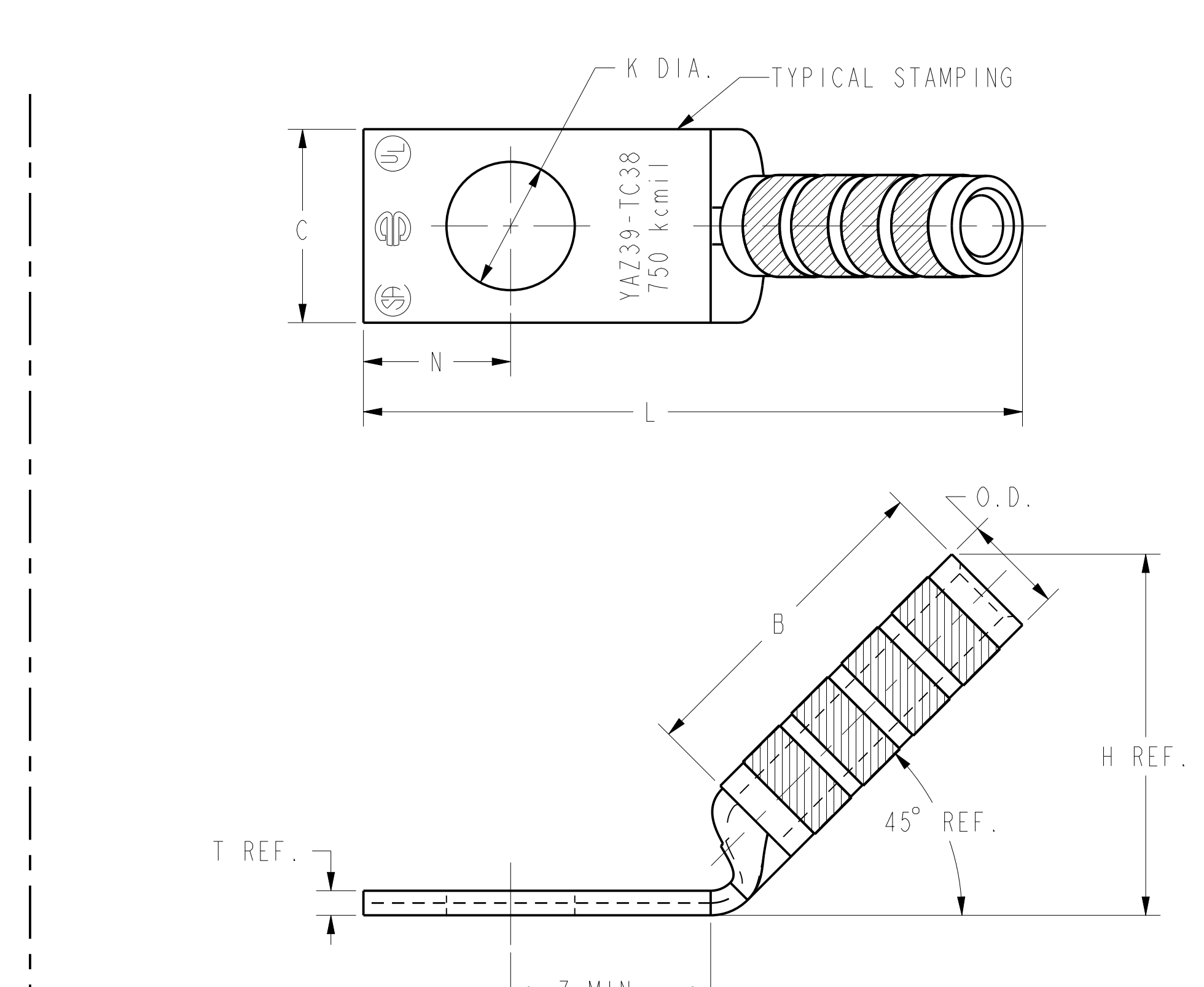
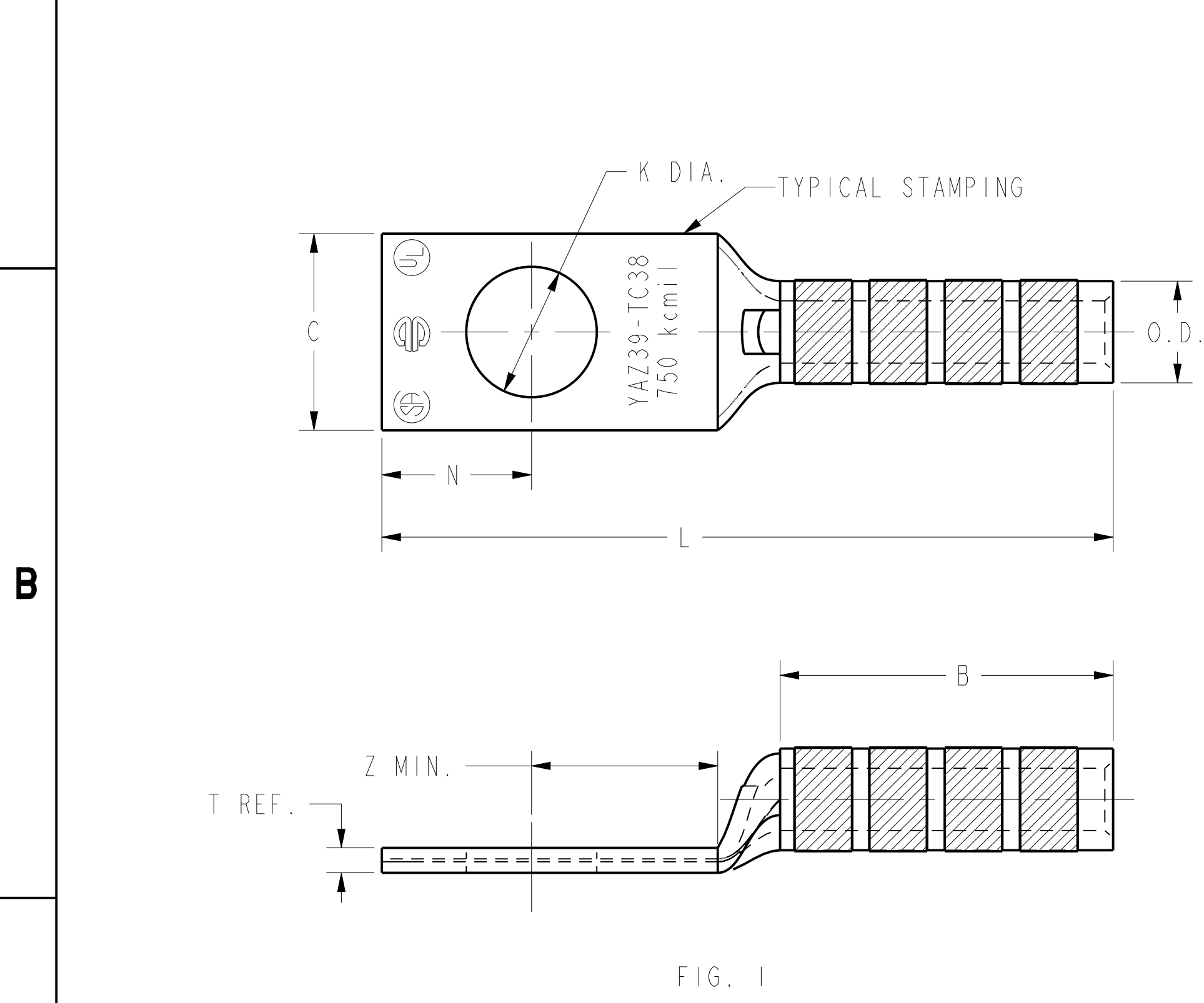

- NOTES:
- MATERIAL: COPPER TUBING.
 - FINISH: TIN PLATED
 - CATALOG # PT6515 ADAPTOR IS REQUIRED TO USE "U" DIES IN Y45 SERIES TOOLS.
 - CATALOG # PUADP-1 ADAPTOR IS REQUIRED TO USE "U" DIES IN Y46 SERIES TOOLS.
 - DIMENSIONS, METRIC WIRE, & METRIC BOLT SIZES IN BRACKETS [] ARE IN MILLIMETERS. DIMENSIONS ARE ROUNDED OFF TO THE NEAREST MILLIMETER, UNLESS OTHERWISE NOTED, AND ARE FOR REFERENCE ONLY.

TO ORDER BURNDY® PRODUCTS CALL		HYLUG™ (ONE HOLE CODE)	
UNITED STATES 1-800-346-4175 (LONDONDERRY, NH)		ITEM NO: NA	CAT. NO: YAZ39- (TABLE)
CANADA: 1-800-361-6975 (QUEBEC) 1-800-387-6487 (ALL OTHER PROVINCES)		DRAWN BY: D. BOISVERT 02/03/2000	CHECKER: K. MCCARTHY 04/05/2000
FOR PRODUCT INFO: http://www.burndy.com		DSN APPVL: J. MICHAUD 05/04/2000	MFG APPVL: N/A
		GA APPVL: S. BROWN	MKT APPVL: N/A
		PROD FAM: --	SCALE: NTS
		PROJECT #: --	DRAWING NO: SE212356
		DOCUMENT TYPE: Sales	REV: B
		REL LEVEL: Released	SHEET 31 OF 40