

REV	DATE	DESCRIPTION	ECO	BY	C.H.K.
B	05/08/2017 00:00:00 AM	LOGO UPDATE	46692	BK	MB

CATALOG NO.	CONDUCTOR		BOLT SIZE	FIG. NO.	DIMENSIONS									INSTALLATION TOOLING (# CRIMPS)							
	CODE (AWG)	NAVY			B ±.09	C ±.06	H REF.	K DIA. ±.02	L ±.15	N ±.06	O.D. ±.01	T REF.	Z MIN.	DIE INDEX	COLOR CODE	HYDRAULIC				DIELESS (# CRIMPS)	WIRE STRIP LENGTH
																Y46	Y45	Y48B	Y60B		
YAZ486TC12				1			--		7.34 [186]												
YAZ486TC1245	2500 kcmil [-----]	---	1/2 [M12]	2	4.69 [119]	3.46 [88]	6.28 [160]	.52 [13]	6.71 [170]	.53 [13]	2.38 [60]	.52 [13]	.55 [14]	--	---	---	---	L486RT (4)	---	4-3/4	
YAZ486TC1290				3			7.23 [184]		2.60 [66]												

C

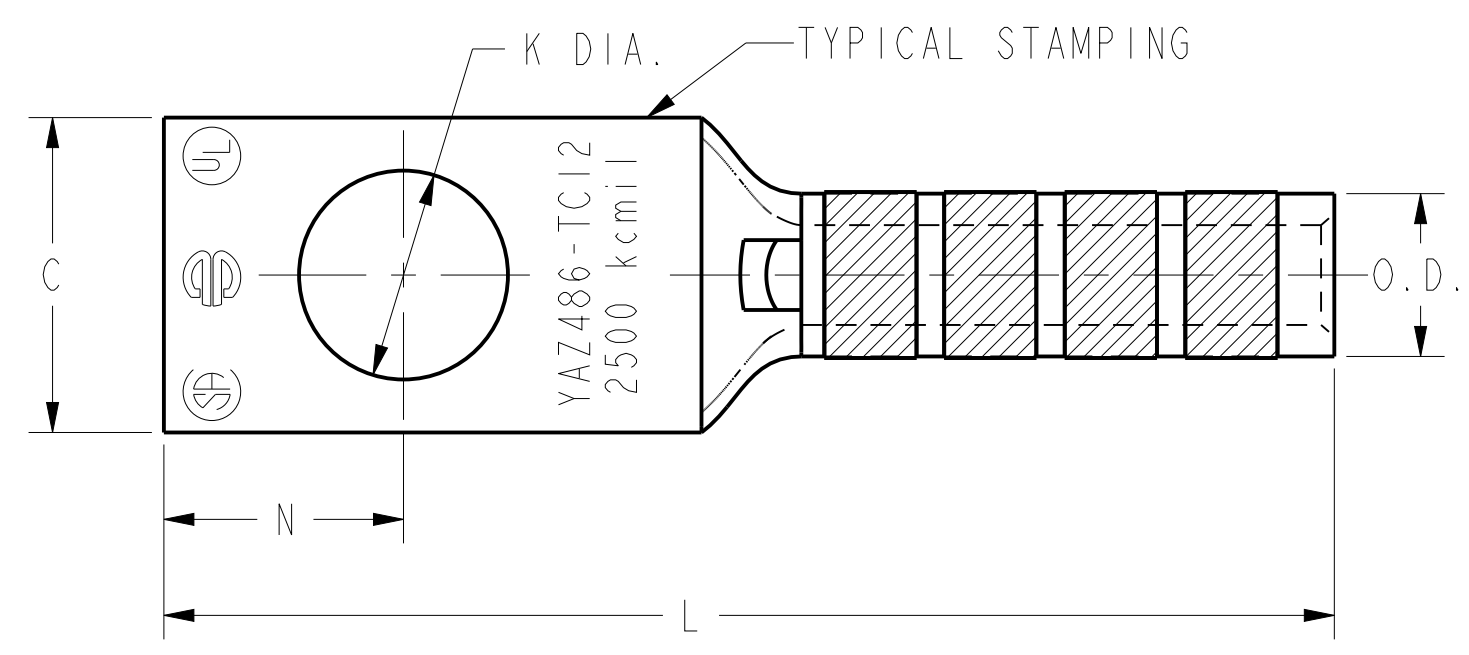

B

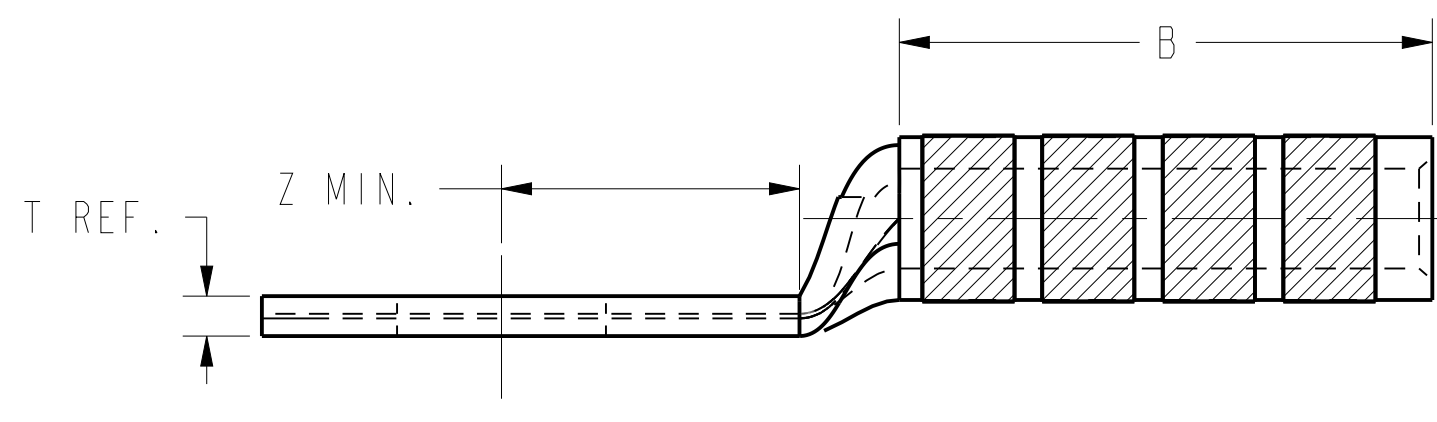

FIG. 1

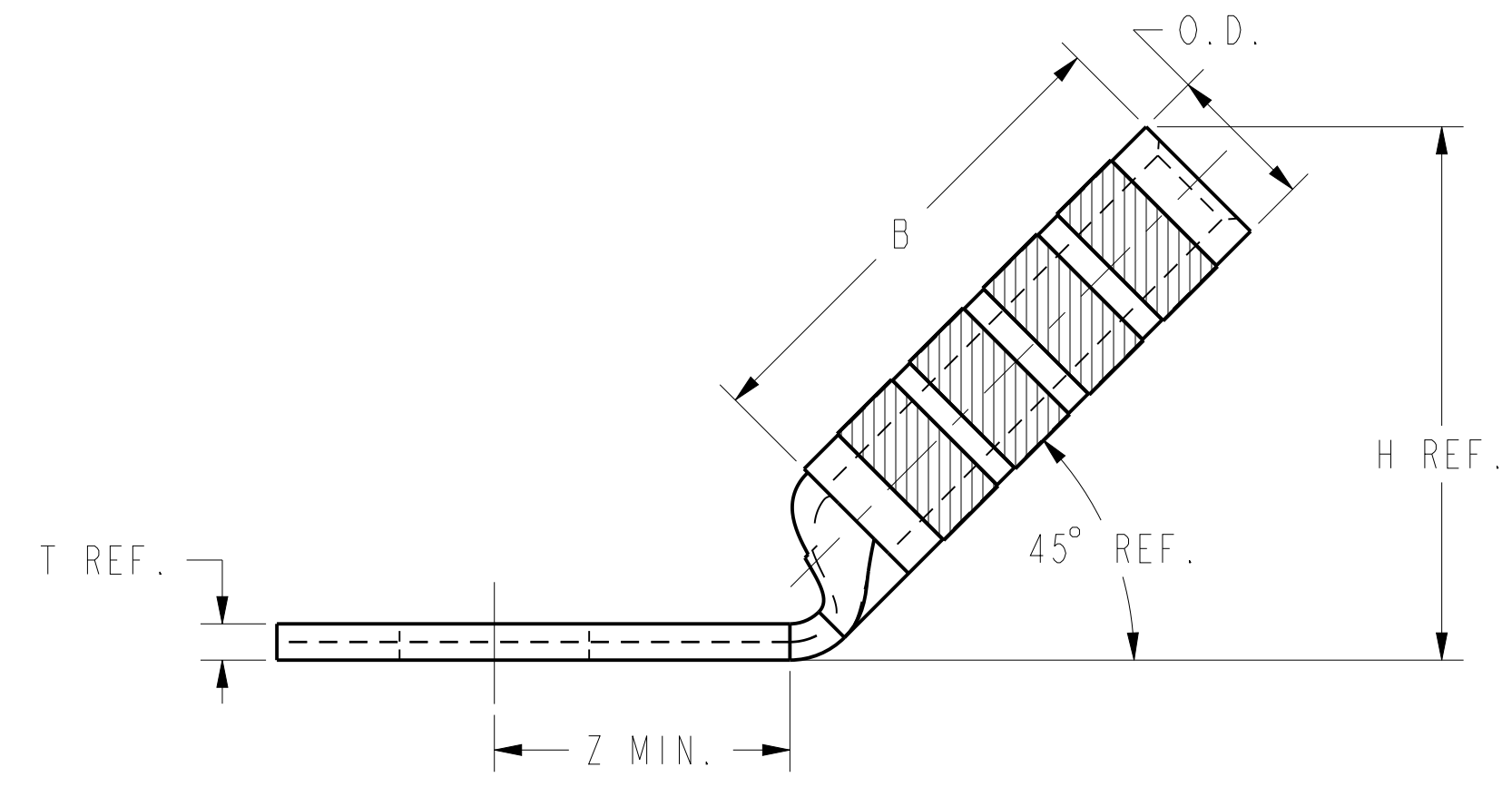
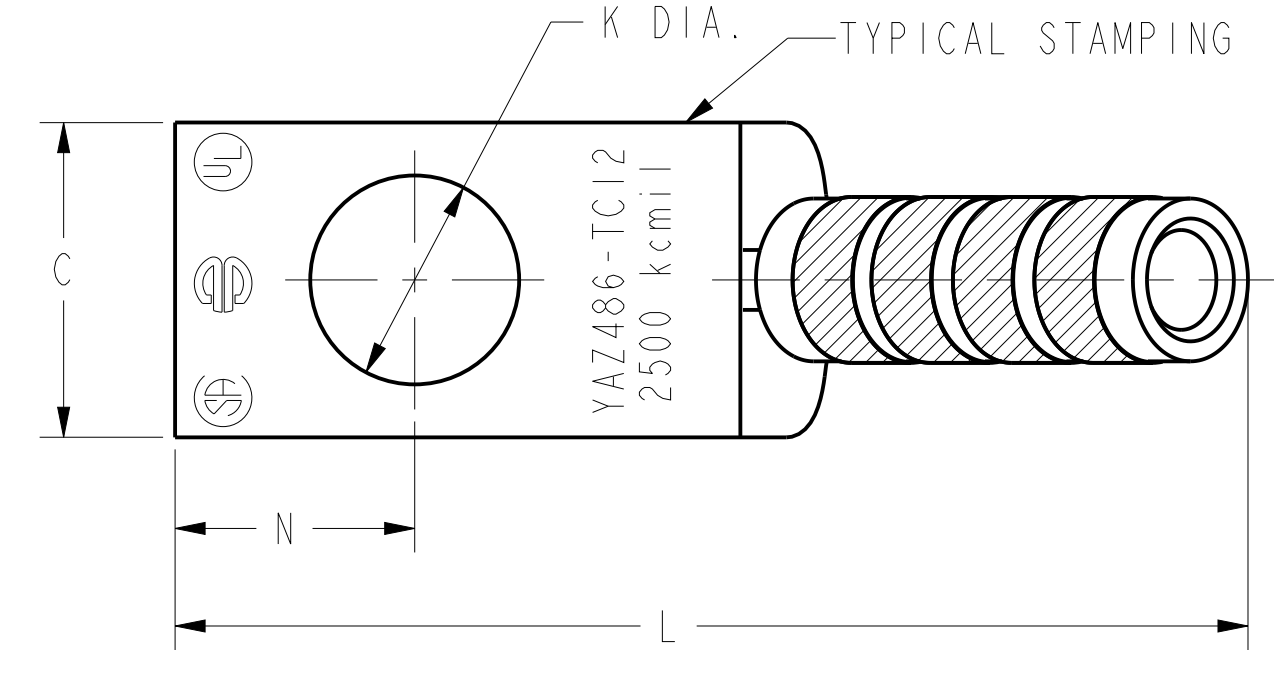

FIG. 2

D

C

B

A

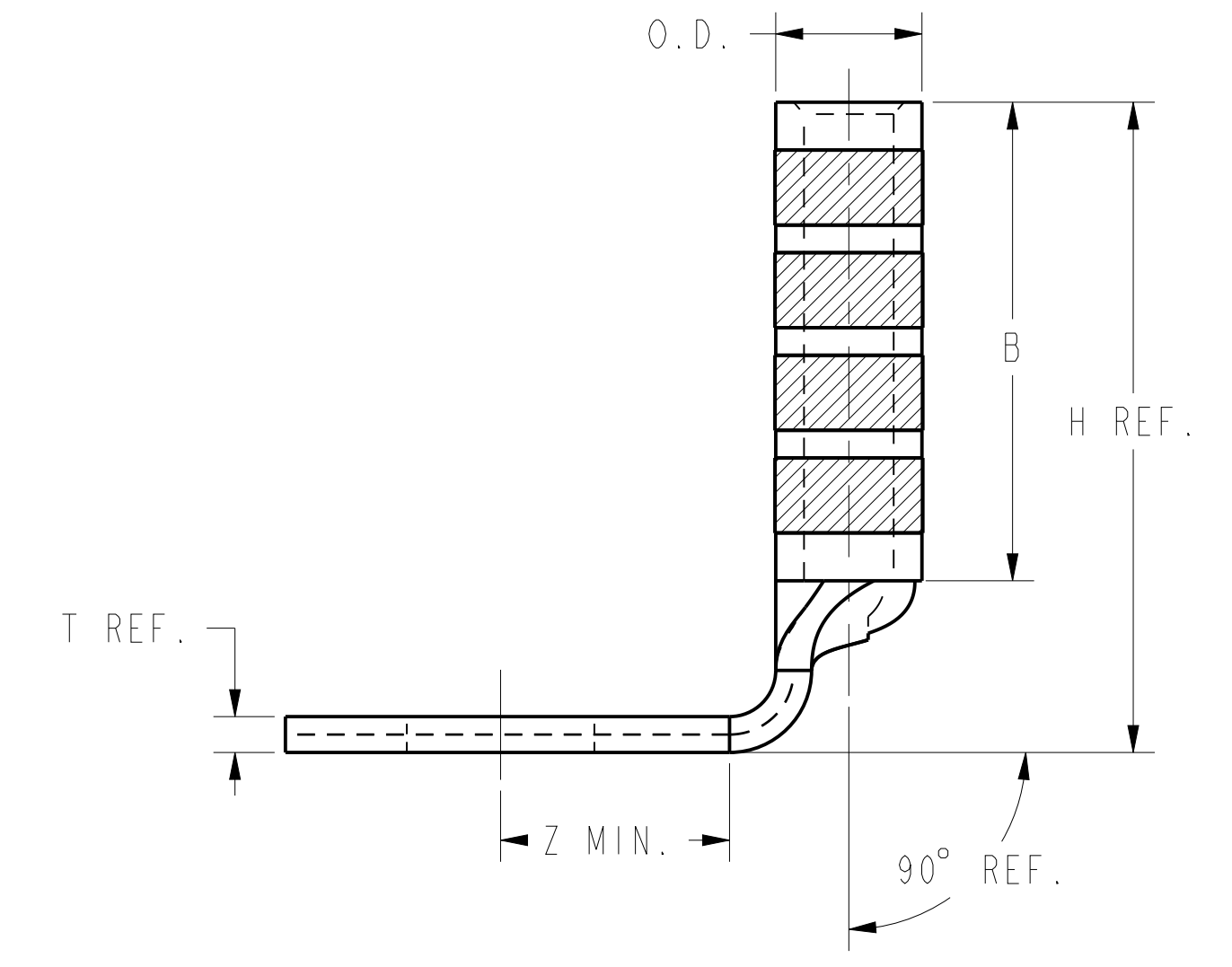
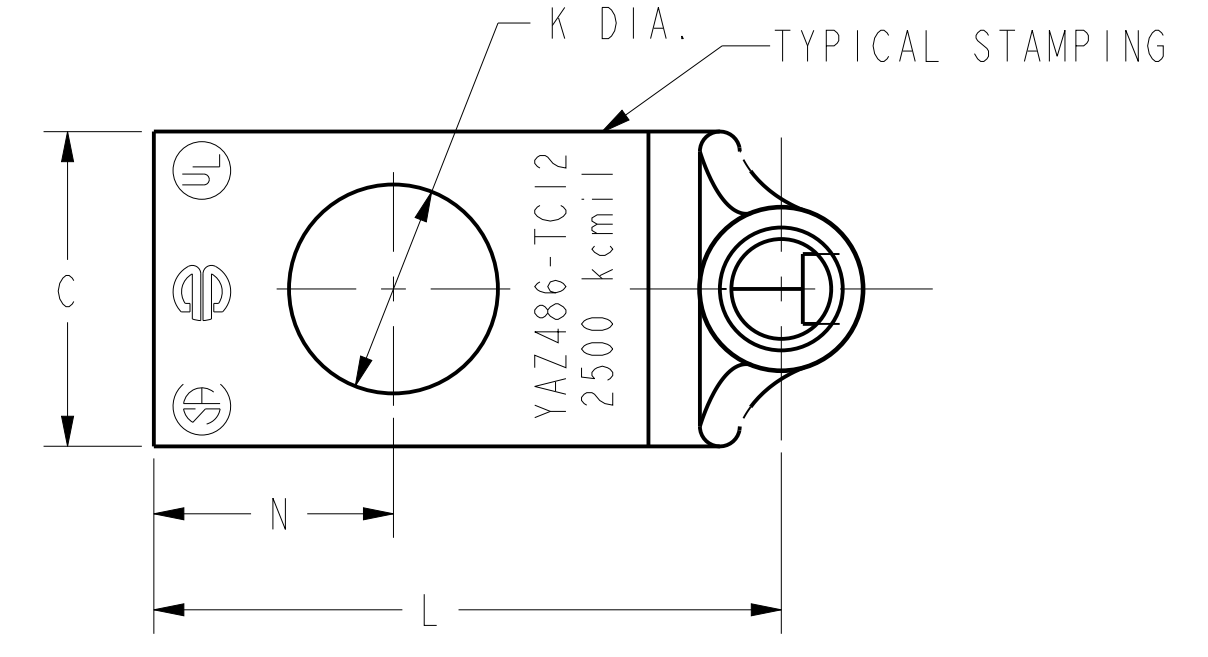

FIG. 3

NOTES:

- MATERIAL: COPPER TUBING.
- FINISH: TIN PLATED
- CATALOG # PT6515 ADAPTOR IS REQUIRED TO USE "U" DIES IN Y45 SERIES TOOLS.
- CATALOG # PUADP-1 ADAPTOR IS REQUIRED TO USE "U" DIES IN Y46 SERIES TOOLS.
- DIMENSIONS, METRIC WIRE, & METRIC BOLT SIZES IN BRACKETS [] ARE IN MILLIMETERS. DIMENSIONS ARE ROUNDED OFF TO THE NEAREST MILLIMETER, UNLESS OTHERWISE NOTED, AND ARE FOR REFERENCE ONLY.

TO ORDER BURNDY® PRODUCTS CALL		HYLUG™ (ONE HOLE CODE)	
UNITED STATES 1-800-346-4175 (LONDONDERRY, NH)		ITEM NO: NA	CAT. NO: YAZ486-TC- (TABLE)
CANADA: 1-800-361-6975 (QUEBEC) 1-800-387-6487 (ALL OTHER PROVINCES)		DRAWN BY: D. BOISVERT 02/03/2000	CHECKER: K. MCCARTHY 04/05/2000
FOR PRODUCT INFO: http://www.burndy.com		DSN APPVL: J. MICHAUD 05/04/2000	MFG APPVL: N/A
		QA APPVL: S. BROWN	MKT APPVL: N/A
		PROD FAM: --	SCALE: NTS
		PROJECT #: --	DRAWING NO
		DOCUMENT TYPE: Sales	REV
		REL LEVEL: Released	SE212356
			SHEET 40 OF 40

REV: PEG200