

D

C

B

A

D

C

B

A

CATALOG NO.	CONDUCTOR		BOLT SIZE	FIG. NO.	DIMENSIONS								INSTALLATION TOOLING (# CRIMPS)													
	CODE (AWG)	NAVY			B	C	H	K DIA.	L	N	O.D.	T REF.	Z MIN.	DIE INDEX	COLOR CODE	MECHANICAL			HYDRAULIC				DIELESS (# CRIMPS)	WIRE STRIP LENGTH		
					±.06	±.04	MAX.	±.02	±.15	±.06	±.01					MD7-34R MD6	OUR840	Y8MRB-1 Y2MR	BCT500 Y500CT	Y750 Y35,PAT35 Y39,PAT750	Y46	Y45				
YAZ8CTC10	8 AWG CLASS B,C G,H,I,K,M 8 AWG SOL 6 AWG SOL	23	#10 [M5]	1	.75 [19]	--		1.43 [36]						49	RED	W8CRT (2)	X8CRT (2)	RED (2)	W8CRT (2)	Y8CRT (2)	Y46 (2)	Y45 (2)	MECHANICAL: MY29- (1)	13/16		
YAZ8CTC1045				2		.41 [10]	.91 [23]	.21 [5]	1.37 [35]		.25 [6]						W8CVT (2)	W8CVT (2)								
YAZ8CTC1090				3				1.00 [25]		.74 [19]																
YAZ8CTC14	10 MM ² CLASS 2 & 5	23	1/4 [M6]	1		--		1.56 [40]											X8CRT (2)	W8CRT (2)	W8CVT (2)					
YAZ8CTC1445				2		.44 [11]	.90 [23]	.27 [7]	1.48 [38]		.31 [8]															
YAZ8CTC1490				3				1.00 [25]		.86 [22]																
YAZ8CTC38	8 AWG CLASS B,C G,H,I,K,M 8 AWG SOL 6 AWG SOL	23	3/8 [M10]	1		--		1.75 [44]																		
YAZ8CTC3845				2		.58 [15]	.90 [23]	.40 [10]	1.62 [41]		.41 [10]															
YAZ8CTC3890				3				1.00 [25]		1.04 [26]																
YAZ8CTC516	10 MM ² CLASS 2 & 5	23	5/16 [M8]	1		--		1.62 [41]																		
YAZ8CTC51645				2		.52 [13]	.90 [23]	.33 [8]	1.52 [39]		.34 [9]															
YAZ8CTC51690				3				1.00 [25]		.92 [23]																

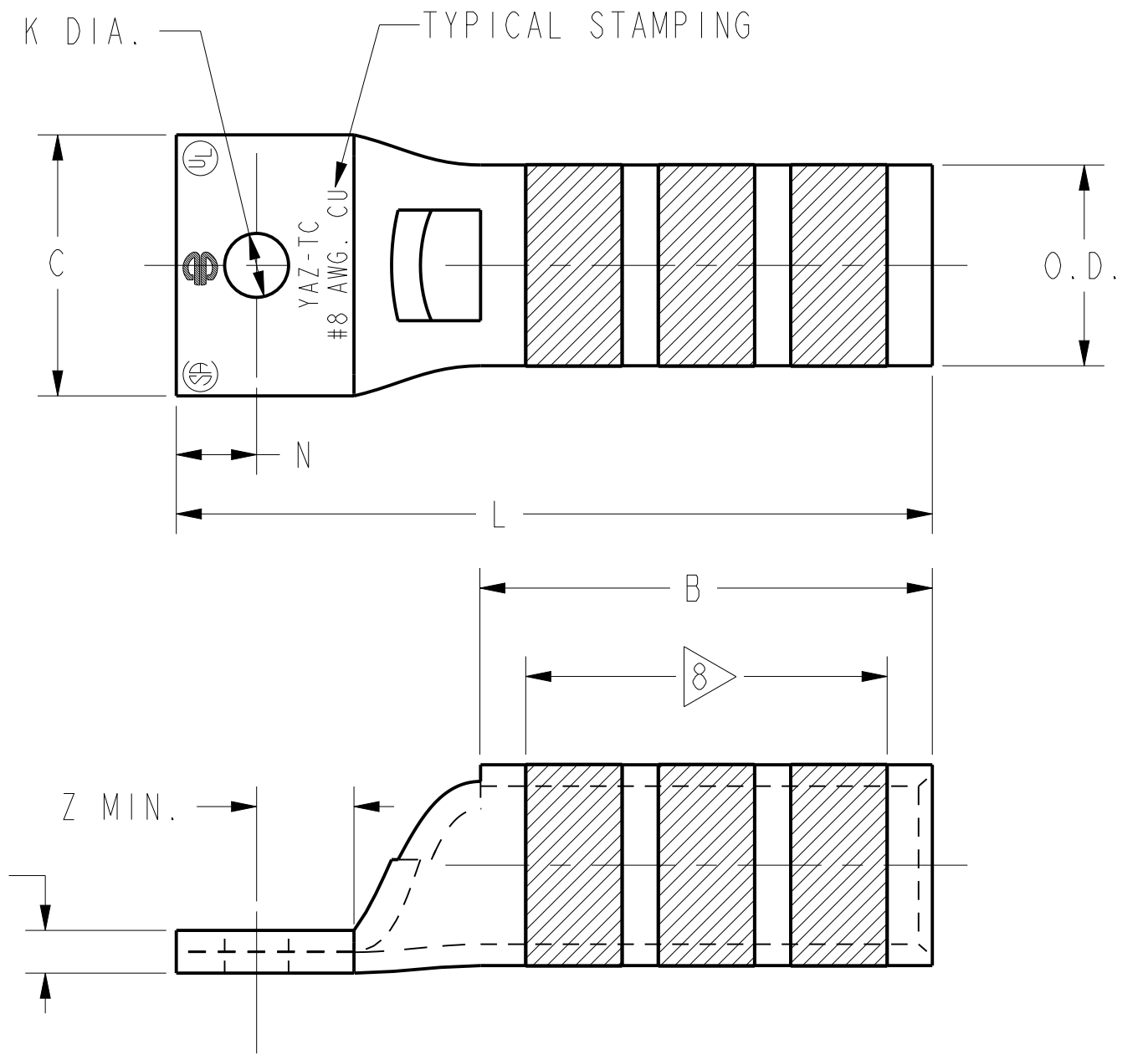

FIG. 1

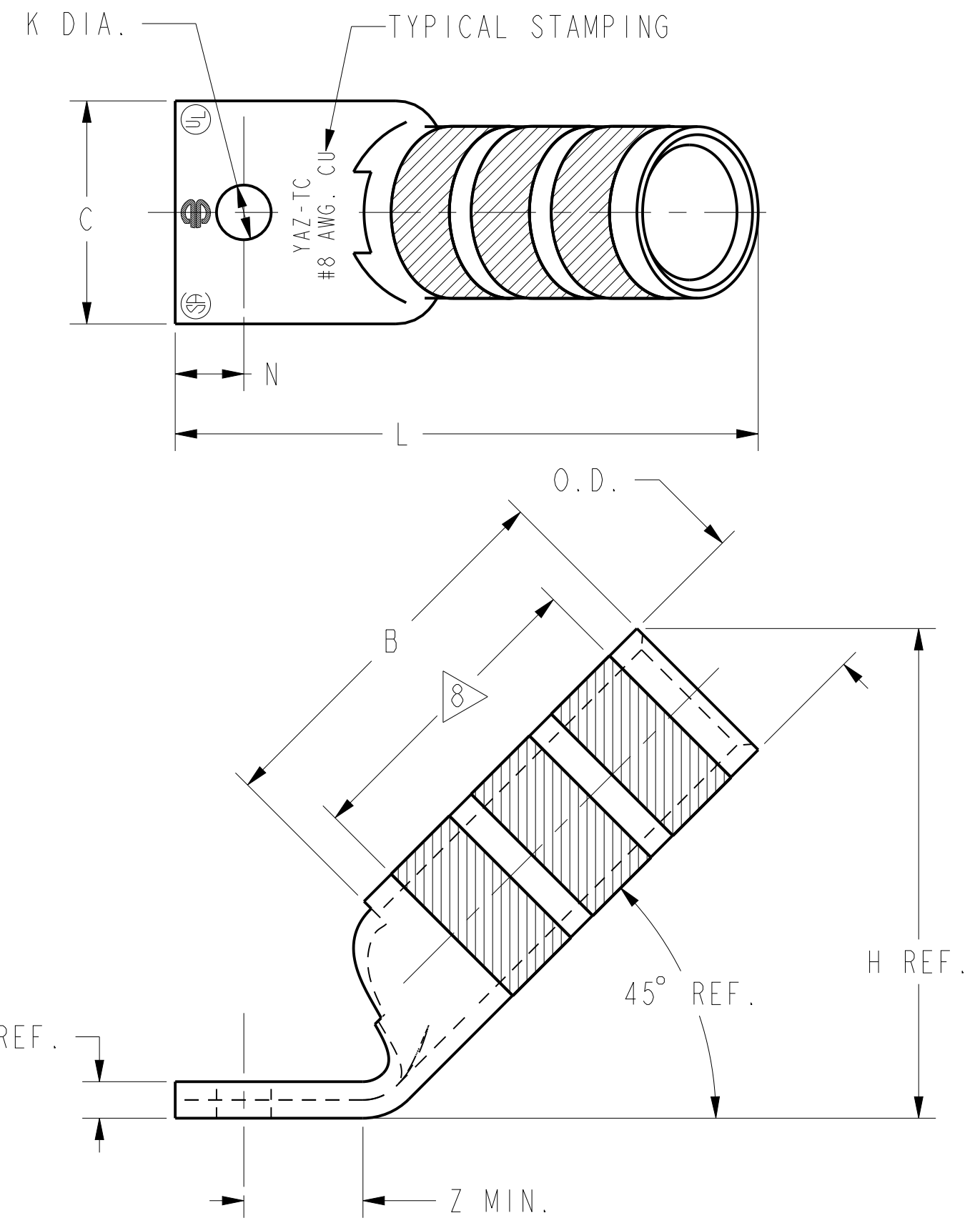

FIG. 2

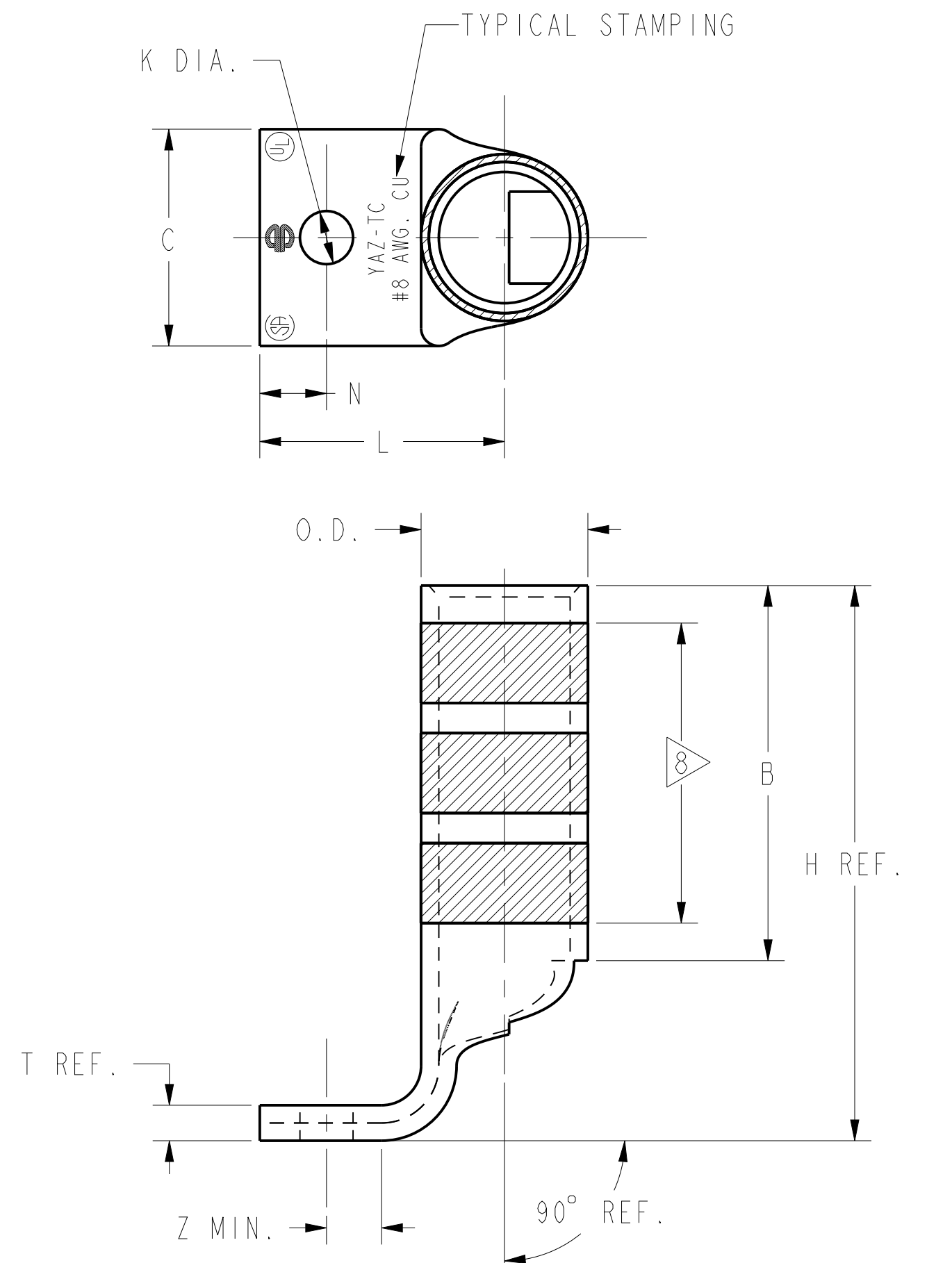

FIG. 3

NOTES:

- MATERIAL: COPPER TUBING.
- FINISH: TIN PLATED
- CATALOG # PT6515 ADAPTOR IS REQUIRED TO USE " U " DIES IN Y45 SERIES TOOLS.
- CATALOG # PUADP-1 ADAPTOR IS REQUIRED TO USE " U " DIES IN Y46 SERIES TOOLS.
- NAVY CABLE SIZE MAY BE OMITTED ON SOME SIZES BECAUSE OF SPACE LIMITATIONS.
- PERMANENT DIE IN TOOLING.
- DIMENSIONS IN BRACKETS [] ARE IN MILLIMETERS. DIMENSIONS ARE ROUNDED OFF TO THE NEAREST MILLIMETER, UNLESS OTHERWISE NOTED, AND ARE FOR REFERENCE ONLY.
- OVERLAP 2 CRIMPS AS NEEDED WITHIN THE LENGTH BETWEEN THE INK STAMPED CRIMPING AREA.
- UL LISTED AND CSA CERTIFIED CONNECTOR.
- THESE CATALOG NUMBERS CANNOT BE INSTALLED WITH U8CRT DIE.

TO ORDER BURNDY@PRODUCTS CALL UNITED STATES: 1-800-346-4175 (LONDONDERRY, NH) CANADA: 1-800-361-6975 (QUEBEC) 1-800-387-6487 (ALL OTHER PROVINCES) FOR PRODUCT INFO: http://www.burndy.com		HYLUGS™ (ONE HOLE FLEX) ITEM NO: --- CAT. NO: YAZ8C-TC- (TABLE) DRAWN BY: D. BOISVERT 08/22/00 CHECKER: J. MICHAUD 08/28/00 DSN APPVL: J. MICHAUD 08/21/00 MFG APPVL: T. THRELFALL QA APPVL: T. WATTS MKT APPVL: J. SYLVIA PROD FAM: CM&R COMPRESSION PROJECT #: --- DOCUMENT TYPE: Sales REL LEVEL: Released			
REV D DATE 2023-04-05 00:00:00 EDT DESCRIPTION UPDATED AS PER MARKUP ECO 230113026947 BY YR C'H'K. RA	SCALE: 1:1 DRAWING NO SE212448 SHEET 1 OF 16		D		

REV: CREO 08/10/21