

CATALOG NO.	CONDUCTOR		BOLT SIZE	FIG. NO.	DIMENSIONS								INSTALLATION TOOLING (# CRIMPS)												
	FLEX	CODE (AWG)			B	C	H	K DIA.	L	N	O.D.	T REF.	Z MIN.	DIE INDEX	COLOR CODE	MECHANICAL		HYDRAULIC			DIELESS (# CRIMPS)	WIRE STRIP LENGTH			
																MD7-34R	BCT500 Y500CT	Y750, PAT750 Y35, PAT35 Y39, PAT750	Y46	Y45					
YAZ34NT38FX	350 kcmil CLASS G,H,I K,M 373.3 DLO (924/24)	---	3/8 [M10]	1	2.25 [57]	--	.40 [10]	3.84 [98]	.41 [10]	1.06 [27]	.23 [6]	.42 [11]	19	BLUE	W32RT W32VT (4)	W32RT W32VT (4)	U32RT (4)	U32RT (4)	U32RT (4)	HYDRAULIC: Y644, Y644M Y644MBH PAT644 (1) Y81KFT-PAT81KFT-Y4PC-PAT4PC-SERIES (2)	2-5/16				
YAZ34NT38FX45				2		.96 [24]		2.94 [75]														3.49 [89]	.42 [11]		
YAZ34NT38FX90				3		3.41 [87]		1.53 [39]														1.06 [27]	.23 [6]	.42 [11]	
YAZ34TC38FX				1		--		3.84 [98]														.41 [10]	1.06 [27]	.23 [6]	.42 [11]
YAZ34TC38FXNK				1		--		3.84 [98]														.41 [10]	1.06 [27]	.23 [6]	.42 [11]
YAZ34TC38FXSV				1		--		3.84 [98]														.41 [10]	1.06 [27]	.23 [6]	.42 [11]
YAZ34TC38FX45				2		2.94 [75]		3.49 [89]														.42 [11]			
YAZ34TC38FX90				3		3.41 [87]		1.53 [39]														1.06 [27]	.23 [6]	.42 [11]	
YAZ34TC12FX				1		--		4.09 [104]														.53 [13]	1.06 [27]	.23 [6]	.55 [14]
YAZ34TC12FX45				2		2.94 [75]		3.74 [95]														.53 [13]	1.06 [27]	.23 [6]	.55 [14]
YAZ34TC12FX90				3		3.41 [87]		1.78 [45]														.53 [13]	1.06 [27]	.23 [6]	.55 [14]
YAZ34TC58FX				5/8 [M16]		--		4.34 [110]														.66 [17]	1.06 [27]	.23 [6]	.67 [17]
YAZ34NT12FX	1/2 [M12]	--	4.09 [104]	.53 [13]	1.06 [27]	.23 [6]	.55 [14]																		

REV	DATE	DESCRIPTION	ECO	BY	C'H'K.
G	2020-06-08 11:26:00 EDT	MU UPDATION	53690	SS	WP

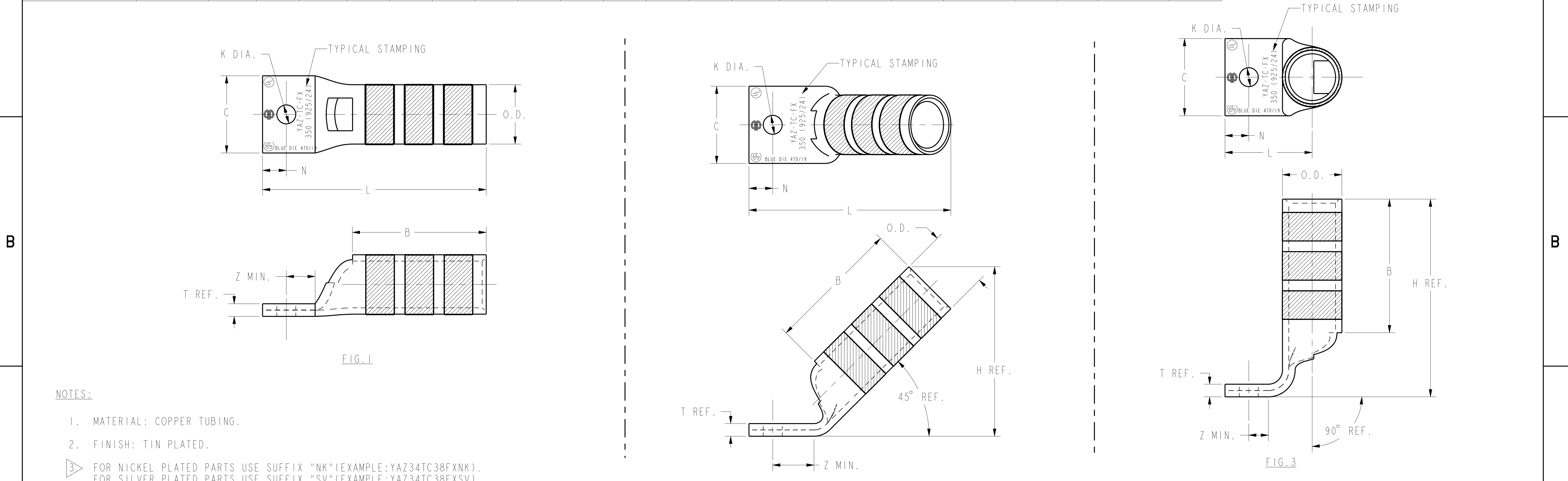

- NOTES:**
- MATERIAL: COPPER TUBING.
 - FINISH: TIN PLATED.
 - FOR NICKEL PLATED PARTS USE SUFFIX "NK"(EXAMPLE:YAZ34TC38FXNK). FOR SILVER PLATED PARTS USE SUFFIX "SV"(EXAMPLE:YAZ34TC38FXSV).
 - CATALOG # PT6515 ADAPTOR IS REQUIRED TO USE " U " DIES IN Y45 SERIES TOOLS.
 - CATALOG # PUADP-1 ADAPTOR IS REQUIRED TO USE " U " DIES IN Y46 SERIES TOOLS.
 - DIMENSIONS IN BRACKETS [] ARE IN MILLIMETERS. DIMENSIONS ARE ROUNDED OFF TO THE NEAREST MILLIMETER, UNLESS OTHERWISE NOTED, AND ARE FOR REFERENCE ONLY.
 - UL LISTED AND CSA CERTIFIED WIRE CONNECTOR.

TO ORDER BURNDY® PRODUCTS CALL		HYLUGS™ (ONE HOLE FLEX)	
UNITED STATES 1-800-346-4175 (LONDONDERRY, NH)		ITEM NO: ---	SCALE: 1:1
CANADA: 1-800-361-6975 (QUEBEC) 1-800-387-6487 (ALL OTHER PROVINCES)		CAT. NO: YAZ34- (TABLE)	DRAWING NO: SE212448
FOR PRODUCT INFO: http://www.burndy.com		DRAWN BY: D. BOISVERT 08/22/00	REV: G
		CHECKER: J. MICHAUD 08/28/00	
		DSN APPVL: J. MICHAUD 08/21/00	
		MFG APPVL: T. THRELFALL ---	
		GA APPVL: T. WATTS ---	
		MKT APPVL: J. SYLVIA ---	
		PROD FAM: CM&R COMPRESSION	SIZE: D
		DOCUMENT TYPE: Sales	SHEET 14 OF 16
		REL LEVEL: Released	