

REV	DATE	DESCRIPTION	ECO	BY	C'H'K.
D	2020-06-08 11:26:00 EDT	MU UPDATION	53690	SS	WP

CATALOG NO.	CONDUCTOR		BOLT SIZE	FIG. NO.	DIMENSIONS								INSTALLATION TOOLING (# CRIMPS)					WIRE STRIP LENGTH							
	FLEX	CODE (AWG)			B ±.09	C ±.06	H REF.	K DIA. ±.02	L ±.12	N ±.03	O.D. ±.01	T REF.	Z MIN.	DIE INDEX	COLOR CODE	Y750, Y35 PAT35, PAT750 Y39, PAT750	Y46		Y45	DIELESS (# CRIMPS)					
YAZ38NT38FX	500 KCMIL CLASS H, I, K 550 KCMIL CLASS G, H, I 535 KCMIL DLO	---	3/8 [M10]	1	2.81 [71]	--	.40 [10]	4.71 [120]	.50 [13]	1.25 [32]	.27 [7]	.52 [13]	L99	PINK	U38XRT UR4140WE (4)	U38XRT UR4140WE (4)	U38XRT UR4140WE (4)	HYDRAULIC: Y644, Y644M PAT644, Y644MBH (1) Y81K-SERIES (2)	2-7/8						
YAZ38NT38FX45				2		1.63 [41]	3.57 [91]	4.25 [108]	.50 [13]																
YAZ38NT38FX90				3		4.16 [106]	1.83 [46]	.50 [13]																	
YAZ38TC38FX				1	1.84 [47]	--	.40 [10]	4.71 [120]	.50 [13]	1.25 [32]	.27 [7]	.52 [13]													
YAZ38TC38FX45				2		3.57 [91]	4.25 [108]	.50 [13]																	
YAZ38TC38FX90				3		4.16 [106]	1.83 [46]	.50 [13]																	
YAZ38NT12FX				1	1/2 [M12]	--	.52 [13]	4.77 [121]	.53 [13]	1.25 [32]	.27 [7]	.55 [14]													
YAZ38NT12FX45				2		1.63 [41]	3.57 [91]	4.31 [109]	.53 [13]																
YAZ38NT12FX90				3		4.16 [106]	1.90 [48]	.53 [13]																	
YAZ38TC12FX				1	1/2 [M12]	--	.52 [13]	4.77 [121]	.53 [13]	1.25 [32]	.27 [7]	.55 [14]													
YAZ38TC12FX45				2		1.84 [47]	3.57 [91]	4.31 [109]	.53 [13]																
YAZ38TC12FX90				3		4.16 [106]	1.90 [48]	.53 [13]																	
YAZ38NT58FX				500 KCMIL CLASS H, I, K 550 KCMIL CLASS G, H, I 535 KCMIL DLO	---	5/8 [M16]	1	2.81 [71]	--	.69 [18]	5.02 [128]	.66 [17]			1.25 [32]	.27 [7]	.67 [17]			L99	PINK	U38XRT UR4140WE (4)	U38XRT UR4140WE (4)	U38XRT UR4140WE (4)	2-7/8
YAZ38NT58FX45							2		1.63 [41]	3.57 [91]	4.56 [116]	.66 [17]													
YAZ38NT58FX90							3		4.16 [106]	2.15 [55]	.66 [17]														
YAZ38TC58FX	1	1.84 [47]	--				.69 [18]		5.02 [128]	.66 [17]															

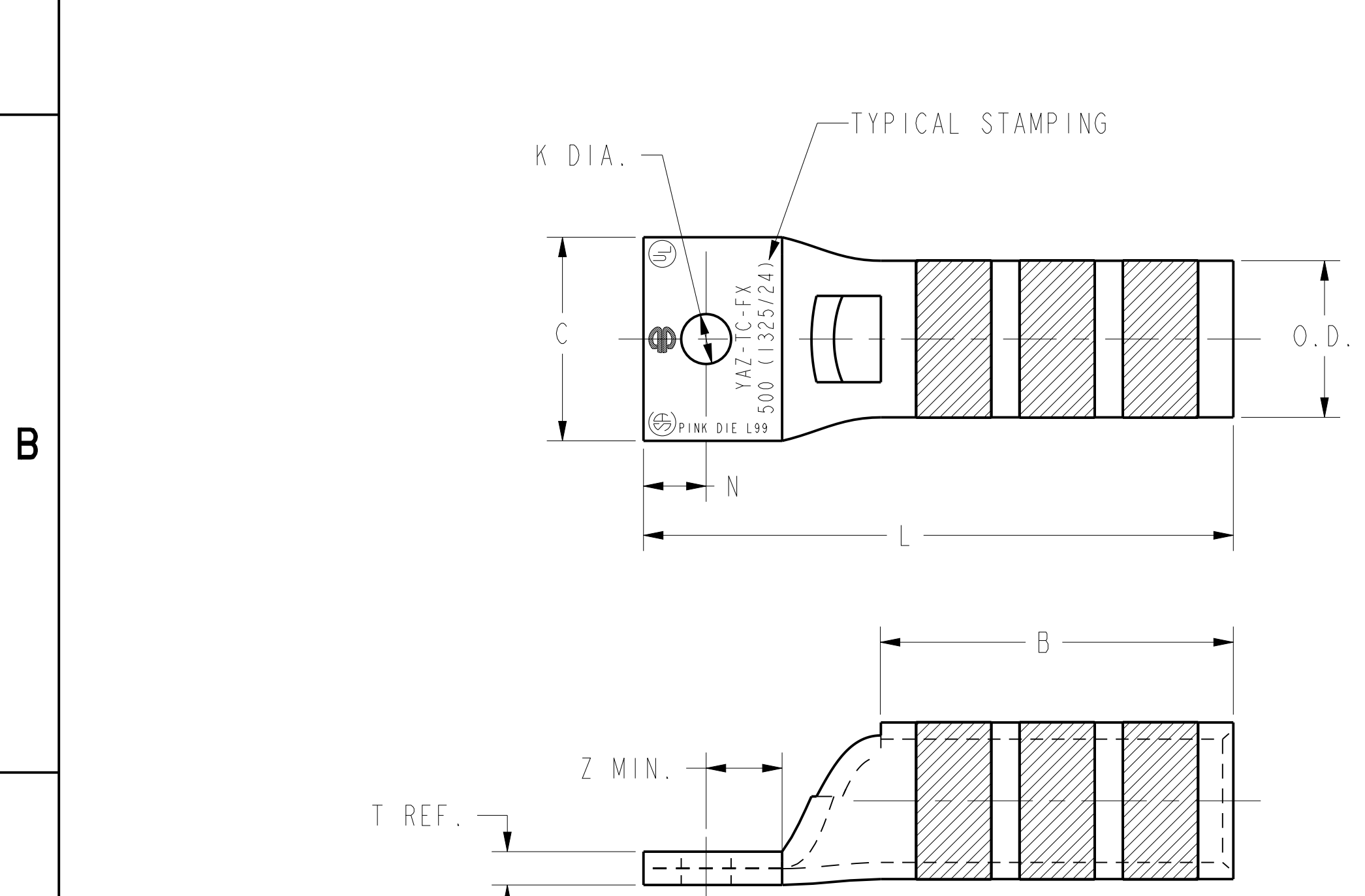

FIG. 1

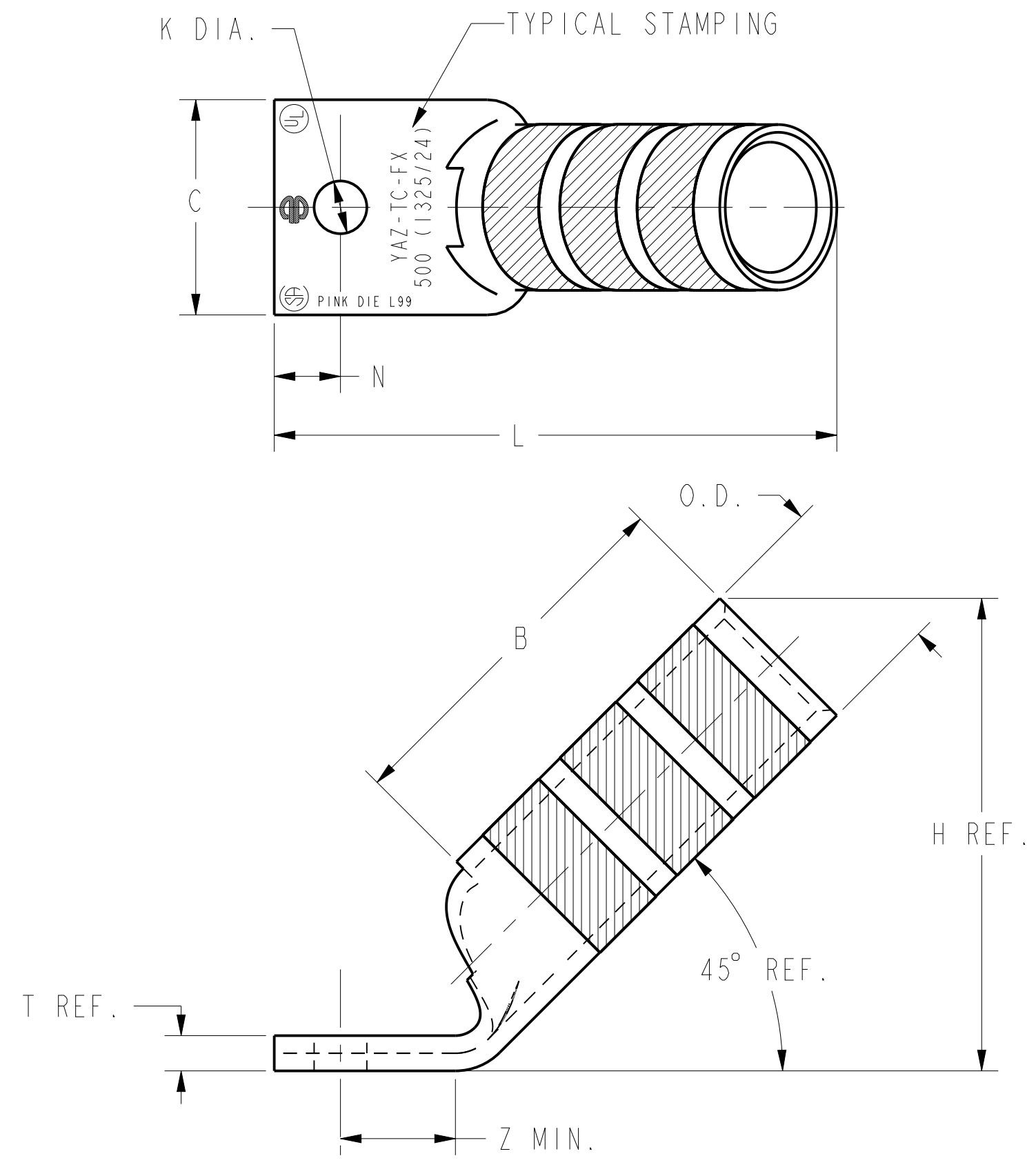

FIG. 2

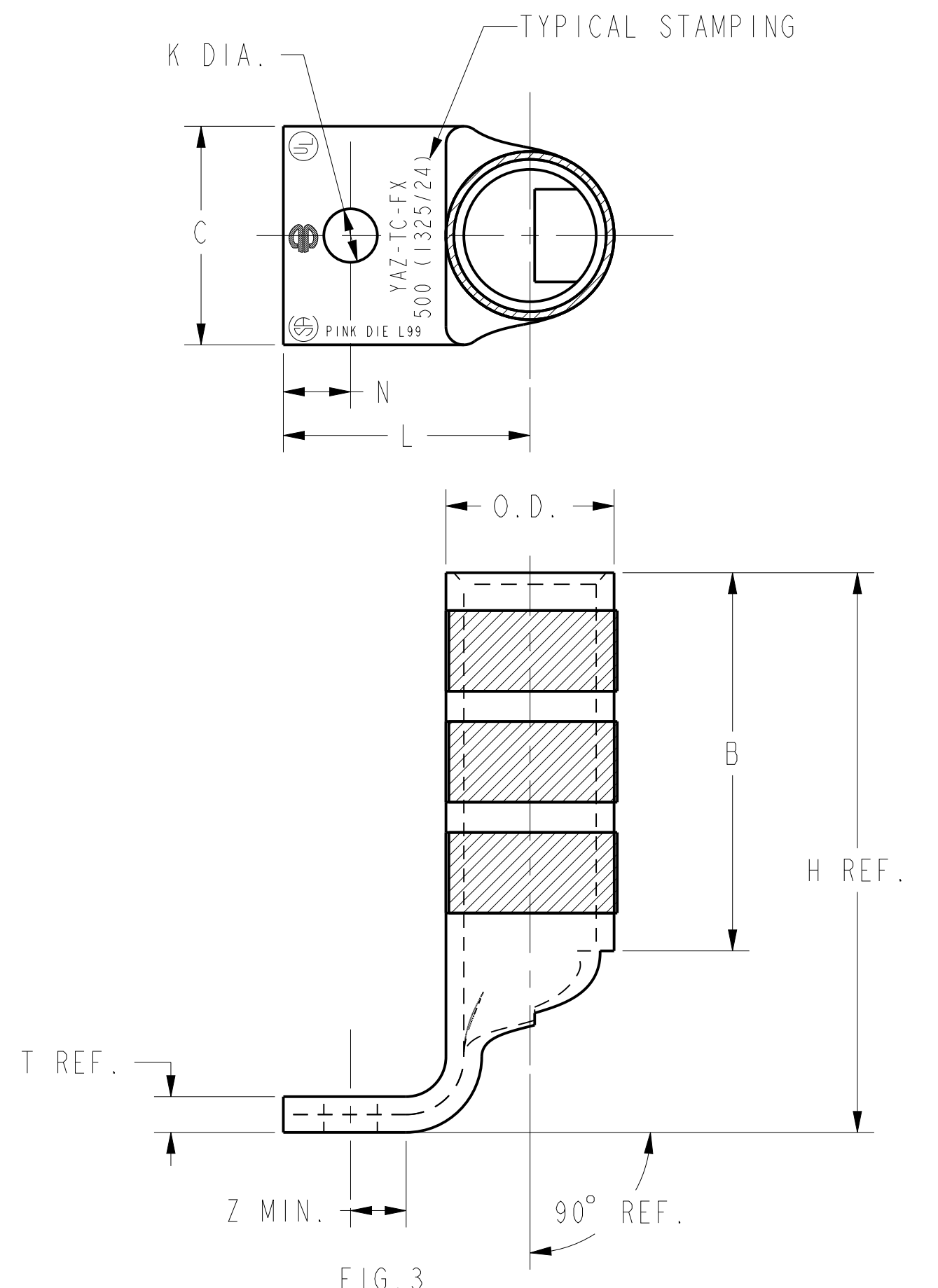

FIG. 3

NOTES:

- MATERIAL: COPPER TUBING.
- FINISH: TIN PLATED
- CATALOG # PT6515 ADAPTOR IS REQUIRED TO USE " U " DIES IN Y45 SERIES TOOLS.
- CATALOG # PUADP-1 ADAPTOR IS REQUIRED TO USE " U " DIES IN Y46 SERIES TOOLS.
- DIMENSIONS IN BRACKETS [] ARE IN MILLIMETERS. DIMENSIONS ARE ROUNDED OFF TO THE NEAREST MILLIMETER, UNLESS OTHERWISE NOTED, AND ARE FOR REFERENCE ONLY.
- UL LISTED AND CSA CERTIFIED CONNECTOR.

TO ORDER BURNDY® PRODUCTS CALL		HYLUGS™ (ONE HOLE FLEX)	
UNITED STATES 1-800-346-4175 (LONDONDERRY, NH)		ITEM NO: ---	
CANADA: 1-800-361-6975 (QUEBEC) 1-800-387-6487 (ALL OTHER PROVINCES)		CAT. NO: YAZ38- (TABLE)	
FOR PRODUCT INFO: http://www.burndy.com		DRAWN BY: D. BOISVERT 08/22/00	
		CHECKER: J. MICHAUD 08/28/00	
		DSN APPVL: J. MICHAUD 08/21/00	
		MFG APPVL: T. THRELFALL --	
		QA APPVL: T. WATTS --	
		MKT APPVL: J. SYLVIA --	
		SCALE: 1:1	
		PROD FAM: CM&R COMPRESSION	
		DRAWING NO: REV	
		PROJECT #: --	
		SIZE: D	
		SE212448	
		SHEET 16 OF 16	
		DOCUMENT TYPE: Sales	
		REL LEVEL: Released	

REV: PE0200