

STRANDED COPPER CONDUCTOR ACCOMMODATED			BOLT SIZE (METRIC)	DIE INFORMATION			INSTALLATION TOOLING (# CRIMPS)										DIELESS (# OF CRIMPS)	WIRE STRIP LENGTH	
CODE (AWG)	NAVY	METRIC SIZE		COLOR CODE	DIE INDEX	TYPE	MECHANICAL (# OF CRIMPS)					HYDRAULIC (# OF CRIMPS)							
							Y1MRTC	OUR840	MD6 MD7	MD6--R2 MD7-34R	PATMD6 PAT600	Y34A Y34B Y34BH	Y35, Y39 Y750, BAT35 PAT750	Y46, PAT46	Y45	Y48B			Y60BHU
#4 AWG	40	---	1/2 (M12)	GRAY	8 OR 346	GRAY DIE SET	GRAY (4)	X4CRT (2)	X4CRT (2) W4CRT (2) W4CVT (2)	X4CRT (2) W4CRT (2) W4CVT (2)	X4CRT (2) W4CRT (2) W4CVT (2)	---	U4CRT (2) U6CABT (2)	U4CRT (2) U6CABT (2)	U4CRT (2) U6CABT (2)	---	---	MECHANICAL: MY29-3 (2), MY29-11 (2), MRC -840 (4) HYDRAULIC: Y644 (1) Y81KFT(1) YY4PC834 (1)	1 -3/16"
						NEST INDENTOR	---	---	---	---	---	B4CD (1) A4CD (1) Y34PR	U4CD-1 (1) Y34PR	U4CD-1 (1) Y34PR	U4CD-1 (1) Y34PR	---	---		

REV	DATE	DESCRIPTION	EC	BY	C'H'K.
B	06/27/2022	UPDATED DIMENSIONS.	220617021301	WP	DD

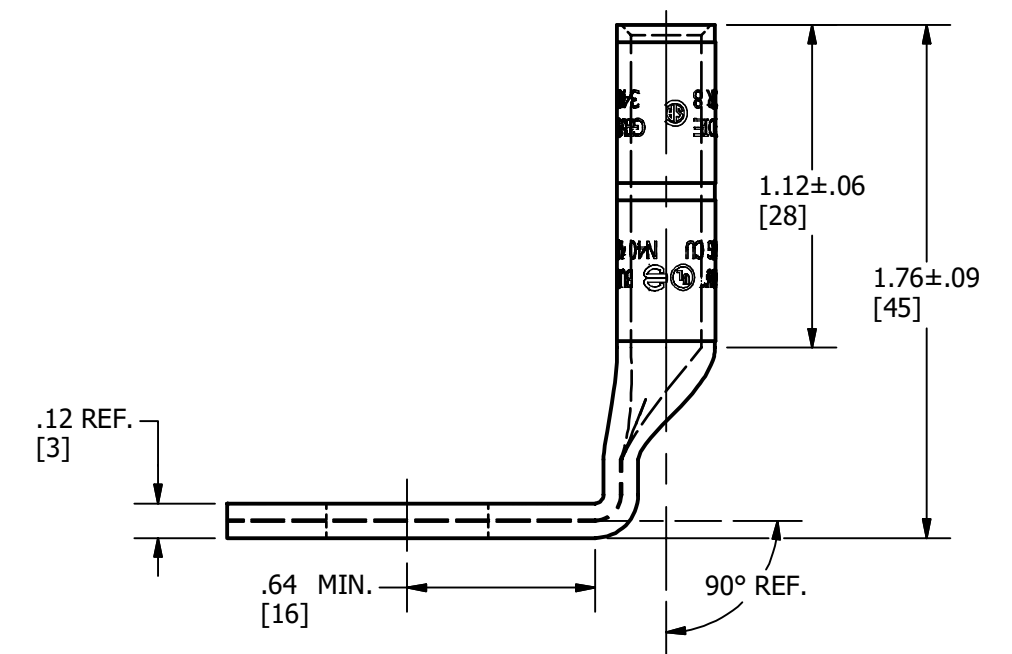
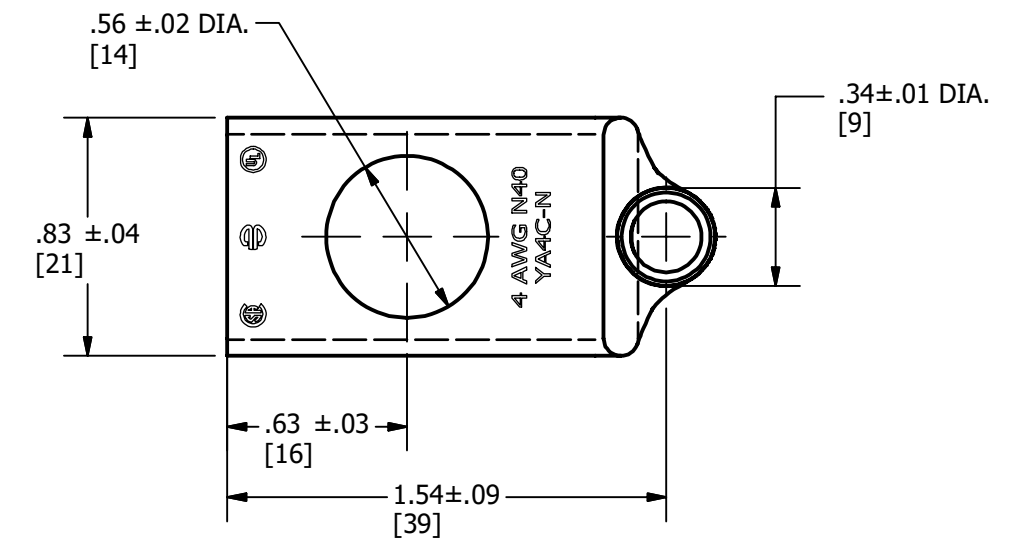

NOTES:

- MATERIAL: COPPER TUBING.
- FINISH: SILVER PLATED.
- CATALOG # PT6515 ADAPTOR IS REQUIRED TO USE "U" DIES IN Y45 SERIES TOOLS.
- CATALOG # PUADP-1 ADAPTOR IS REQUIRED TO USE "U" DIES IN Y46 SERIES TOOLS.
- Y35P3 INDENTOR ADAPTOR REQUIRED FOR Y34PR INDENTOR.
- PERMANENT DIE IN TOOLING.
- DIMENSIONS IN BRACKETS [] ARE IN MILLIMETERS ROUNDED OFF TO THE NEAREST MILLIMETER, UNLESS OTHERWISE SPECIFIED AND ARE FOR REFERENCE ONLY.
- FOR USE BY CUSTOMERS THAT HAVE THIS HYPRESS™ NO NEW Y34A HYPRESS™ TOOLS ARE BEING PROCESSED. Y34A USES A--D TYPE NEST DIES.
- UL LISTED AND CSA CERTIFIED WIRE CONNECTOR.
- "X", "W-RT", "W-VT", "U" & "L" DIE SETS ARE COLOR CODED. "A", "B" AND "C" DIES ARE NOT COLOR CODED. NESTS AND INDENTOR TYPE ARE NOT COLOR CODED.

TO ORDER BURNDY® PRODUCTS CALL		HYLUG™	
UNITED STATES 1-800-346-4175 (LONDONDERRY, NH)		ITEM NO: 50255X CAT. NO: YA4CN90	
CANADA: 1-800-387-6487		DRAWN BY: P.WINSON 06/24/2022 CHECKER: D.DHEENA 06/28/2022 DSN APRVL: J.MICHAUD 06/30/2022 MFG APRVL: T.FOEHRING 08/01/2022 QA APRVL: T.WATTS 06/29/2022 MKT APRVL: --	
FOR PRODUCT INFO: http://www.burndy.com		PROJ #:	SIZE
		DOCUMENT TYPE: SALES	B
		REL LEVEL: Released	
		DRAWING NO	REV
		SE208571-01	B
		SHEET 1 OF 1	