

CATALOG NUMBER	STRANDED COPPER CONDUCTOR ACCOMMODATED			BOLT SIZE	METRIC BOLT SIZE	FIG. NO.	DIMENSIONS								
	CODE (AWG)	NAVY	METRIC SIZE (CLASS 2)				B	C	H REF.	K DIA.	L	N	O.D.	T REF.	Z MIN.
YA4CL445	#4 AWG	40	-----	3/8	-----	1	.81 [21]	.58 [15]	.87 [22]	.40 [10]	1.68 [43]	.41 [10]	.34 [9]	.08 [2]	.42 [11]
2						.58 [15]	1.23 [31]	.40 [10]	1.08 [27]	.41 [10]	.08 [2]	.42 [11]			
1				1/2	M12	.71 [18]	1.03 [26]	.53 [13]	2.02 [51]	.53 [13]	.06 [2]	.55 [14]			
2						.81 [21]	.71 [18]	1.19 [30]	.53 [13]	1.32 [34]	.53 [13]	.06 [2]	.55 [14]		

REV	DATE	DESCRIPTION	ECO	BY	CHK.
C	2023-01-06 00:00:00 EST	UPDATED AS PER MU	221219026524	YR	RA

CONNECTOR SIZE	TOLERANCES					
	B	C	K DIA.	L	N	O.D.
-8C THRU -25	±.06	±.04	±.02	±.09	±.03	±.01
-26 THRU -34	±.08	±.04	±.02	±.12	±.03	±.01
-35 AND UP	±.09	±.06	±.02	±.15	±.06	±.01

TOLERANCE BLOCK

D

D

INSTALLATION TOOLING (# CRIMPS)

CATALOG NO.	COLOR CODE	DIE INFORMATION		MECHANICAL RATCHET				HYDRAULIC						DIELESS (# CRIMPS)	WIRE STRIP LENGTH	
		DIE INDEX	TYPE	YIMRTC	OUR840	MD6 MD7	MD6--R2 MD7-34R	PATMD6 PAT600	Y34A Y34B Y34BH	Y35, Y39 Y750, PAT750	Y46 PAT46	Y45	Y48B			Y60BHU
YA4CL445	GRAY	8 346	GRAY DIE SET	GRAY(2)	X4CRT(1)	X4CRT(1) W4CRT(1) W4CVT(1)	X4CRT(1) W4CRT(1) W4CVT(1)	X4CRT(1) W4CRT(1) W4CVT(1)	-----	U4CRT(1) U6CABT(1)	U4CRT(1) U6CABT(1)	U4CRT(1) U6CABT(1)	-----	-----	MECHANICAL: MY29-3(1) MY29-11(1) MRC840(1)	7/8"
YA4CL490			NEST	-----	-----	-----	-----	-----	B4CD(1) A4CD(1)	U4CD-1(1)	U4CD-1(1)	U4CD-1(1)	-----	-----	HYDRAULIC: Y644(1) Y81KFT(1) Y4PC834(1)	
YA4CL645			INDENTOR	-----	-----	-----	-----	-----	-----	Y34PR	Y34PR	Y34PR	Y34PR	-----	-----	
YA4CL690			-----	-----	-----	-----	-----	-----	-----	-----	-----	-----	-----	-----	-----	

C

C

NOTES:

- MATERIAL : COPPER TUBING.
- FINISH: ELECTRO-TIN PLATED.
- CATALOG # PT6515 ADAPTOR IS REQUIRED TO USE "U" DIES IN Y45 SERIES TOOLS.
- CATALOG # PUADP-1 ADAPTOR IS REQUIRED TO USE "U" DIES IN Y46 SERIES TOOLS.
- Y35P3 INDENTOR ADAPTOR REQUIRED FOR Y34PR INDENTOR.
- PERMANENT DIE IN TOOLING.
- DIMENSIONS IN BRACKETS [] ARE IN MILLIMETERS ROUNDED OFF TO THE NEAREST MILLIMETER, UNLESS OTHERWISE NOTED, AND ARE FOR REFERENCE ONLY.
- FOR USE BY CUSTOMERS THAT HAVE THIS HYPRESS™. NO NEW Y34A HYPRESS™ TOOLS ARE BEING PROCESSED. Y34A USES A--D NEST DIES ONLY.
- CONNECTORS ARE UL LISTED; UNDRILLED VERSIONS ARE NOT UL LISTED.
- CONNECTORS ARE CSA CERTIFIED; UNDRILLED VERSIONS ARE NOT CSA CERTIFIED.
- FOR UNDRILLED VERSIONS ADD SUFFIX "-U" TO END OF CATALOG NUMBER. FOR UNDRILLED VERSIONS, USE D MIN. = N MAX. + Z MIN.
- "X", "W-RT", "W-VT", "U", & "L" DIE SETS ARE COLOR CODED. "A", "B", AND "C" DIES ARE NOT COLOR CODED. NESTS AND INDENTOR TYPE ARE NOT COLOR CODED.
- ADD SUFFIX "LD" = LEAD PLATING, "TZ" = TIN-ZINC, "SV" = SILVER, "NK" = NICKEL PLATING.

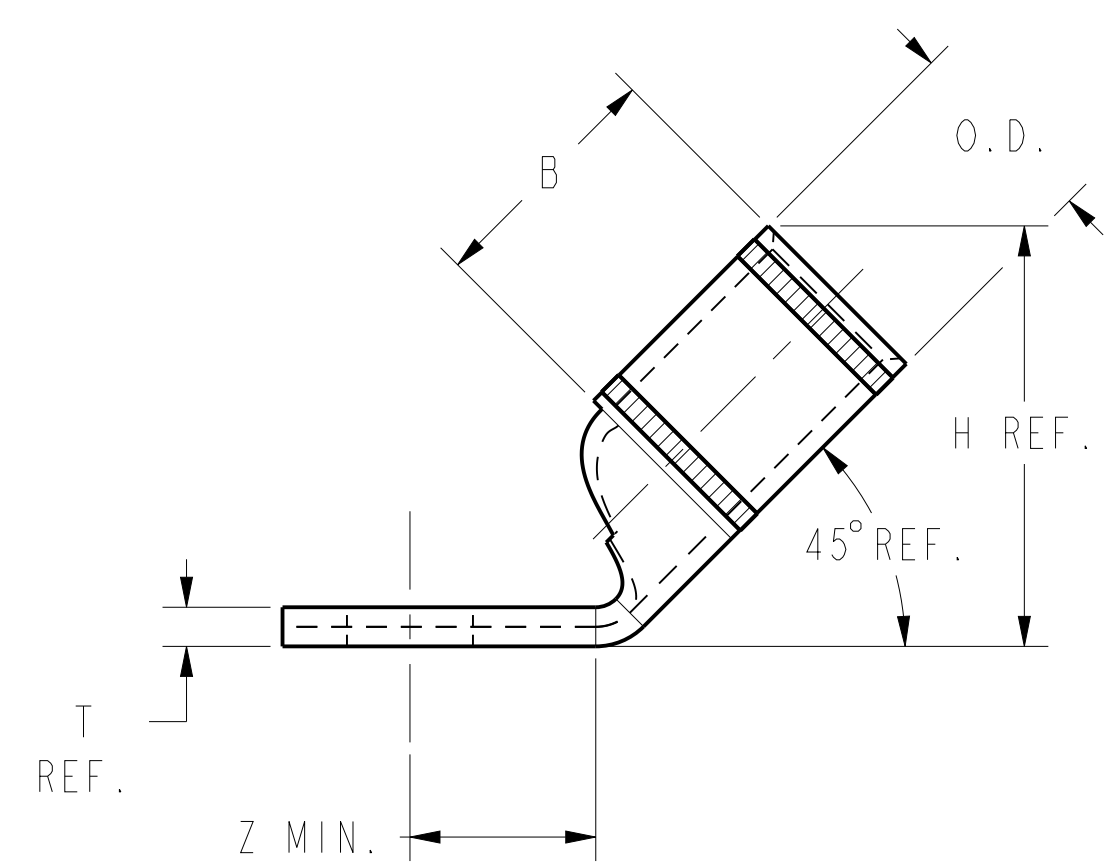
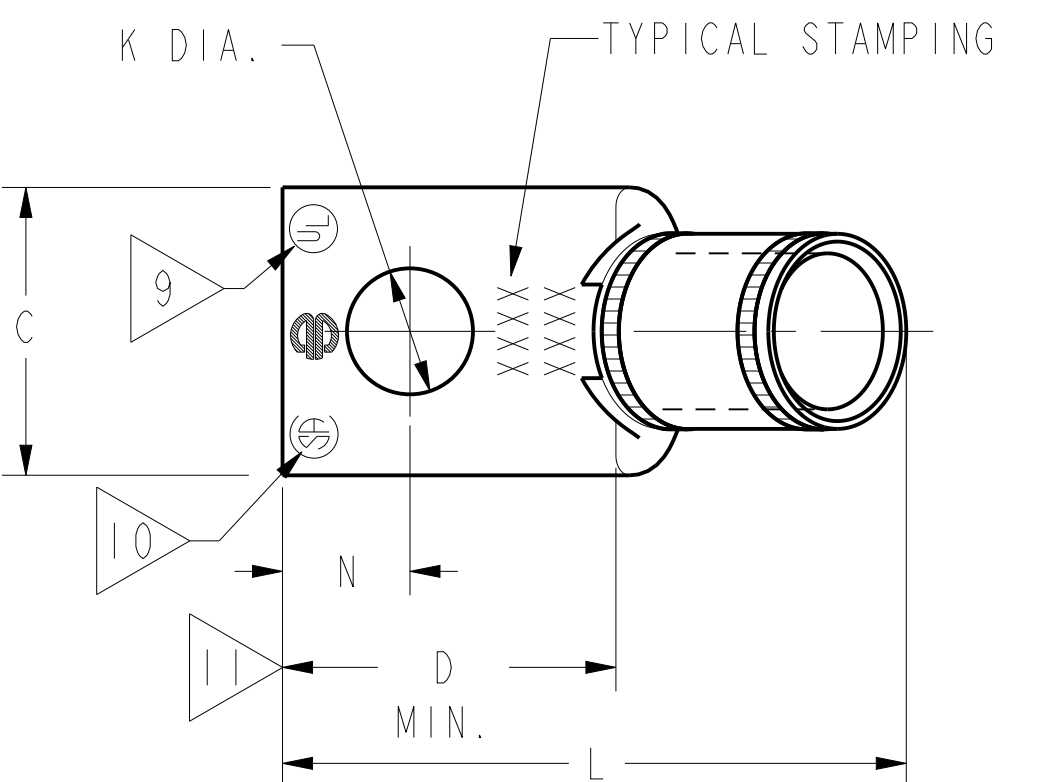

FIG. 1

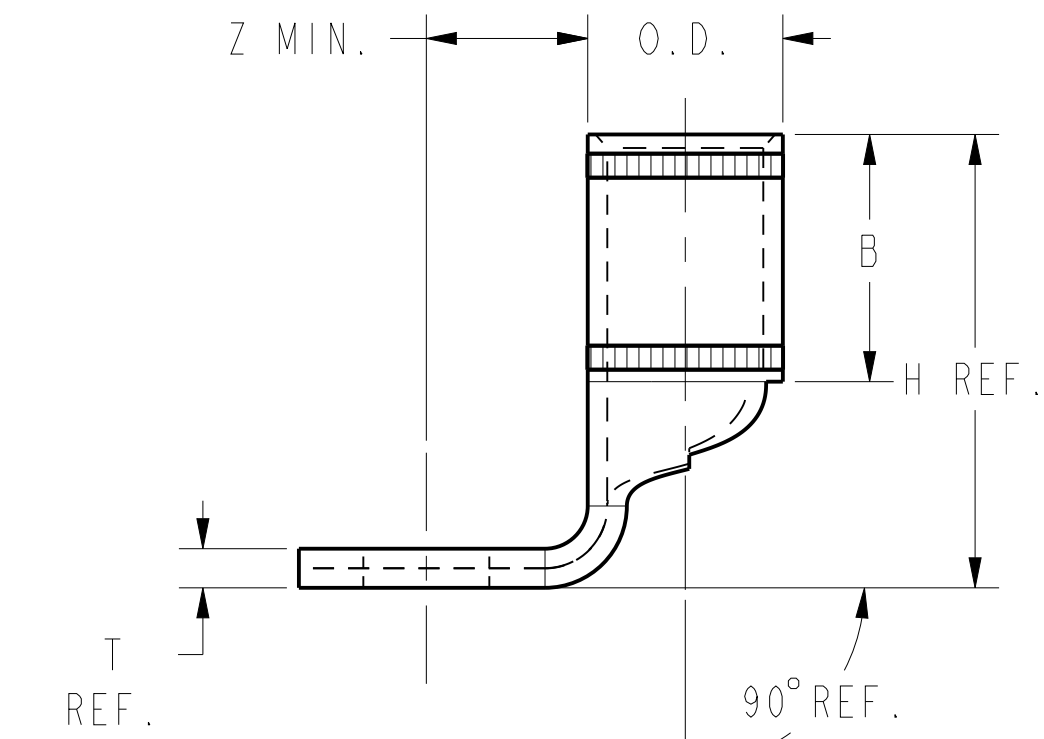
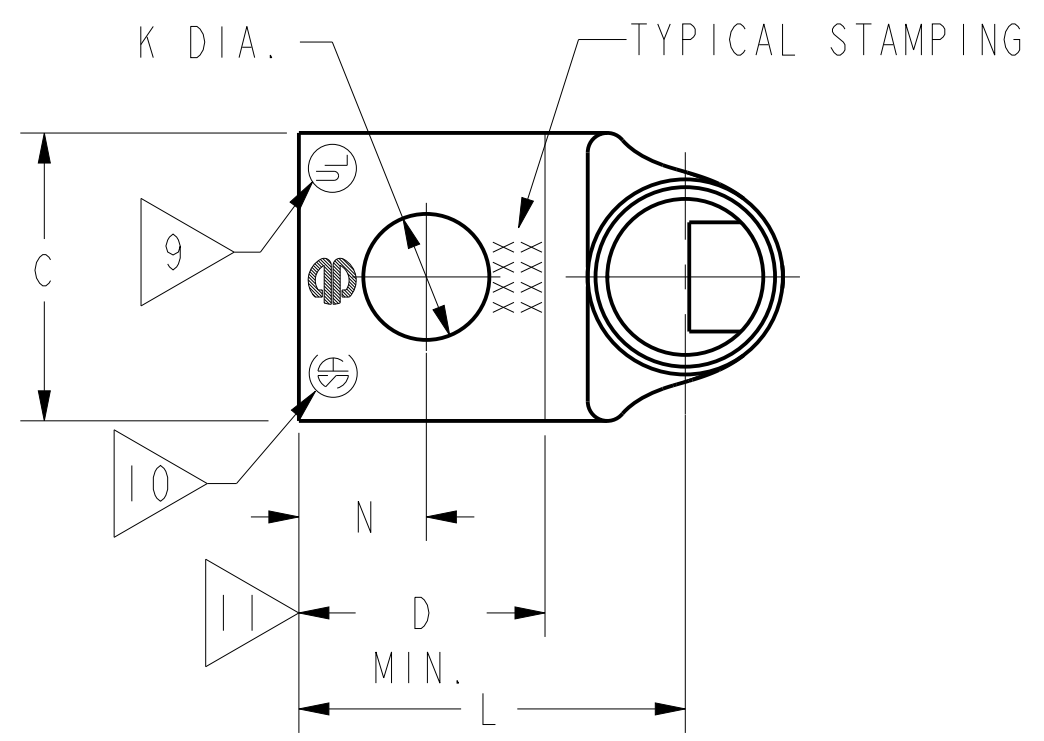

FIG. 2

REFERENCE: SD079848

A

A

TO ORDER BURNDY@PRODUCTS CALL		HYPRESS™ COPPER	
UNITED STATES: 1-800-346-4175 (LONDONDERRY, NH)		ITEM NO: N/A	CAT. NO: YA4CL-L-- (TABLE)
CANADA: 1-800-361-6975 (QUEBEC) 1-800-387-6487 (ALL OTHER PROVINCES)		DRAWN BY: J MICHAUD 12/08/94	CHECKER: D FELLION 12/08/94
FOR PRODUCT INFO: http://www.burndy.com		DSN APPVL: C PALAGI 12/08/94	MFG APPVL: --
		QA APPVL: C ACKERMAN 12/23/94	MKT APPVL: T NELSON 12/15/94
		PROD FAM: CM&R COMPRESSION	DRAWING NO: SE209240
		PROJECT #: --	SIZE: D
		DOCUMENT TYPE: Sales	REL LEVEL: Released
		SCALE: 1:1	
		SHEET 6 OF 38	

REV: CREO_08/10/21