

DRAWING NO. SE209240	7			6		5		4		3		2		1												
	STRANDED COPPER CONDUCTOR ACCOMMODATED			BOLT SIZE	METRIC BOLT SIZE	FIG. NO.	DIMENSIONS								REV	DATE	DESCRIPTION	ECO	BY	C'H'K.						
CATALOG NUMBER	CODE (AWG)	NAVY	METRIC SIZE (CLASS 2)				B	C	H REF.	K DIA.	L	N	O.D.	T REF.	Z MIN.	E	08/12/2013 00:00:00 AM	HEIGHT DIMENSION UPDATED.	32819	BD	MA					
YA25L245	1/0 AWG	100	-----	1/4	M6	1	.88 [22]	.75 [19]	1.28 [32]	.27 [7]	1.76 [45]	.25 [6]	.51 [13]	.12 [3]	.33 [8]											
YA25L290						2																				
YA25L45				5/16	M8	1																				
YA25L90						2																				
YA25L445				3/8	M10	1																				
YA25L490						2	.88 [22]	.75 [19]	1.46 [37]	.41 [10]	1.19 [30]	.41 [10]					.51 [13]	.12 [3]	.33 [8]							

CONNECTOR SIZE	TOLERANCES					
	B	C	K DIA.	L	N	O.D.
-8C THRU -25	±.06	±.04	±.02	±.09	±.03	±.01
-26 THRU -34	±.08	±.04	±.02	±.12	±.03	±.01
-35 AND UP	±.09	±.06	±.02	±.15	±.06	±.01

TOLERANCE BLOCK

INSTALLATION TOOLING (# CRIMPS)																		
CATALOG NO.	COLOR CODE	DIE INFORMATION		MECHANICAL						HYDRAULIC						DIELESS (# CRIMPS)	WIRE STRIP LENGTH	
		DIE INDEX	TYPE	6 YIMRTC	OUR840	MD6 MD7	MD6--R2 MD7-34R	PATMD6 PAT600	Y500CT BCT500 PAT600	8 Y34A Y34B Y34BH	5 Y35, Y39 Y750, PAT750	5 4 Y46 PAT46	5 3 Y45	Y48B	Y60BHU			
YA25L45	PINK	12 348	PINK DIE SET	-----	X25RT(2)	X25RT(2)	X25RT(2)	X25RT(2)	X25RT(2)	X25RT(2)	A25R(1)	U25RT(1)	U25RT(1)	U25RT(1)	-----	-----	MECHANICAL: MY29-3(1) MY29-11(1) MRC840(2)  HYDRAULIC: Y644(1) Y81KFT(1) Y4PC834(1)	15/16"
YA25L90			NEST INDENTOR	-----	-----	-----	-----	-----	-----	-----	B25D(1) A25D(1)	U25D-1(1)	U25D-1(1)	U25D-1(1)	Y34PR	Y34PR		

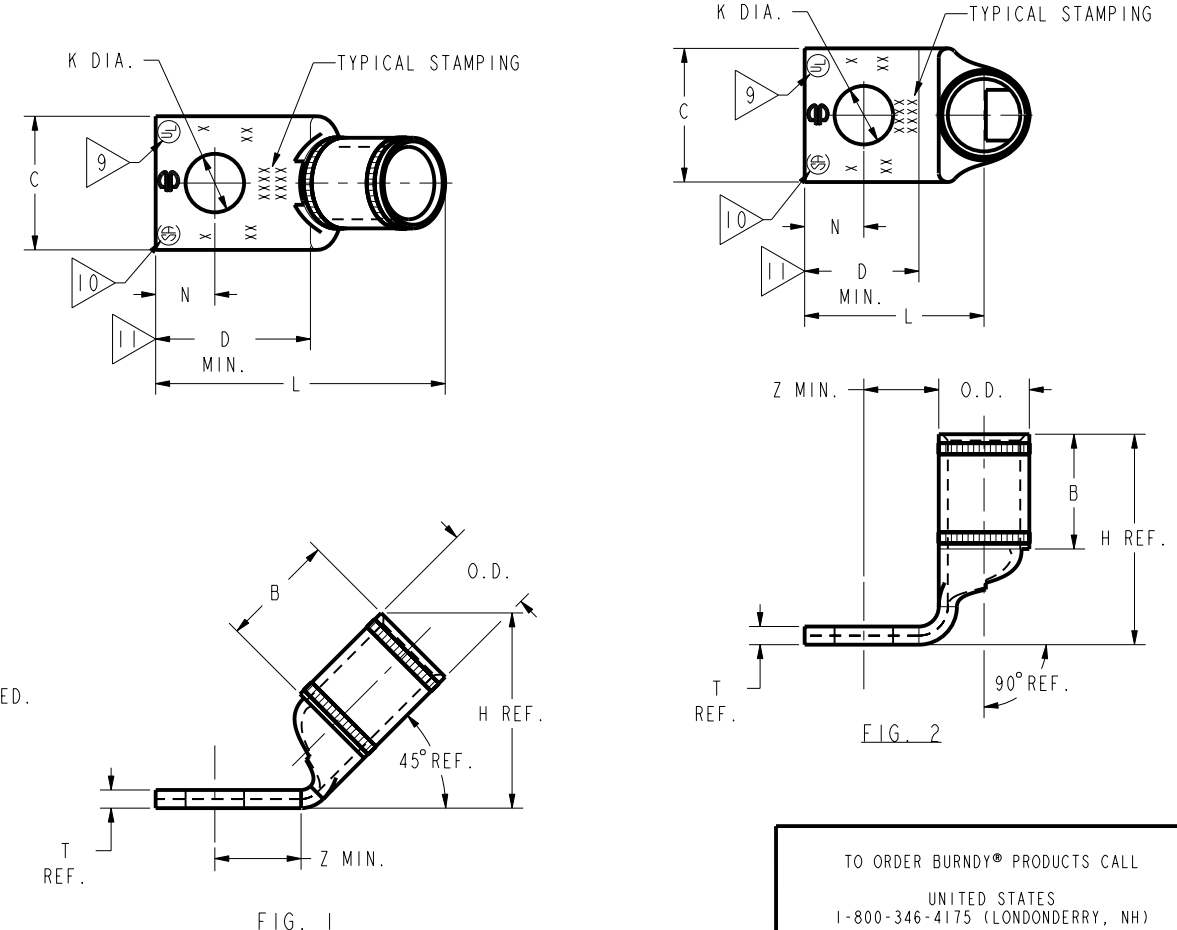

- NOTES:
- MATERIAL : COPPER TUBING.
  - FINISH: TIN PLATED.
  - CATALOG # PT6515 ADAPTOR IS REQUIRED TO USE "U" DIES IN Y45 SERIES TOOLS.
  - CATALOG # PUADP-1 ADAPTOR IS REQUIRED TO USE "U" DIES IN Y46 SERIES TOOLS.
  - Y35P3 INDENTOR ADAPTOR REQUIRED FOR Y34PR INDENTOR.
  - PERMANENT DIE IN TOOLING.
  - DIMENSIONS IN BRACKETS [ ] ARE IN MILLIMETERS ROUNDED OFF TO THE NEAREST MILLIMETER, UNLESS OTHERWISE NOTED, AND ARE FOR REFERENCE ONLY.
  - FOR USE BY CUSTOMERS THAT HAVE THIS HYPRESS™. NO NEW Y34A HYPRESS™ TOOLS ARE BEING PROCESSED. Y34A USES A--D NEST DIES ONLY.
  - CONNECTORS ARE UL LISTED; UNDRILLED VERSIONS ARE NOT UL LISTED.
  - CONNECTORS ARE CSA CERTIFIED; UNDRILLED VERSIONS ARE NOT CSA CERTIFIED.
  - FOR UNDRILLED VERSIONS ADD SUFFIX "-U" TO END OF CATALOG NUMBER. FOR UNDRILLED VERSIONS, USE D MIN. = N MAX. + Z MIN.
  - "X", "W-RT", "W-VT", "U", & "L" DIE SETS ARE COLOR CODED. "A", "B", AND "C" DIES ARE NOT COLOR CODED. NESTS AND INDENTOR TYPE ARE NOT COLOR CODED.

REFERENCE: SD079848

TO ORDER BURNDY® PRODUCTS CALL		HYLUG™ COPPER	
UNITED STATES 1-800-346-4175 (LONDONDERRY, NH)		ITEM NO: N/A	CAT. NO: YA25-L-- (TABLE)
CANADA: 1-800-361-6975 (QUEBEC) 1-800-387-6487 (ALL OTHER PROVINCES)		DRAWN BY: J MICHAUD 12/08/94	CHECKER: D FELLION 12/08/94
FOR PRODUCT INFO: <a href="http://www.burndy.com">http://www.burndy.com</a>		DSN APPVL: C PALAGI 12/08/94	MFG APPVL: --
		QA APPVL: C ACKERMAN 12/23/94	MKT APPVL: T NELSON 12/15/94
		PROD FAM: CM&R COMPRESSION	DRAWING NO: SE209240
		PROJECT #: --	SCALE: 1:1
		DOCUMENT TYPE: Sales	SHEET 12 OF 38
		REL LEVEL: Released	REV: E

REV: PE0200