

REV.	DATE	DESCRIPTION	ECO	BY	C'K'D.
A	02/06/13	UPDATE NOTE PER M/U.	30266	RB	PW

CUTTING CAPACITY
DO NOT CUT ACSR OR ENERGIZED LINE

CU - 1000 KCMIL
AL - 1200 KCMIL
MAX INSUL. DIA. - 1.90 IN. [48.0]

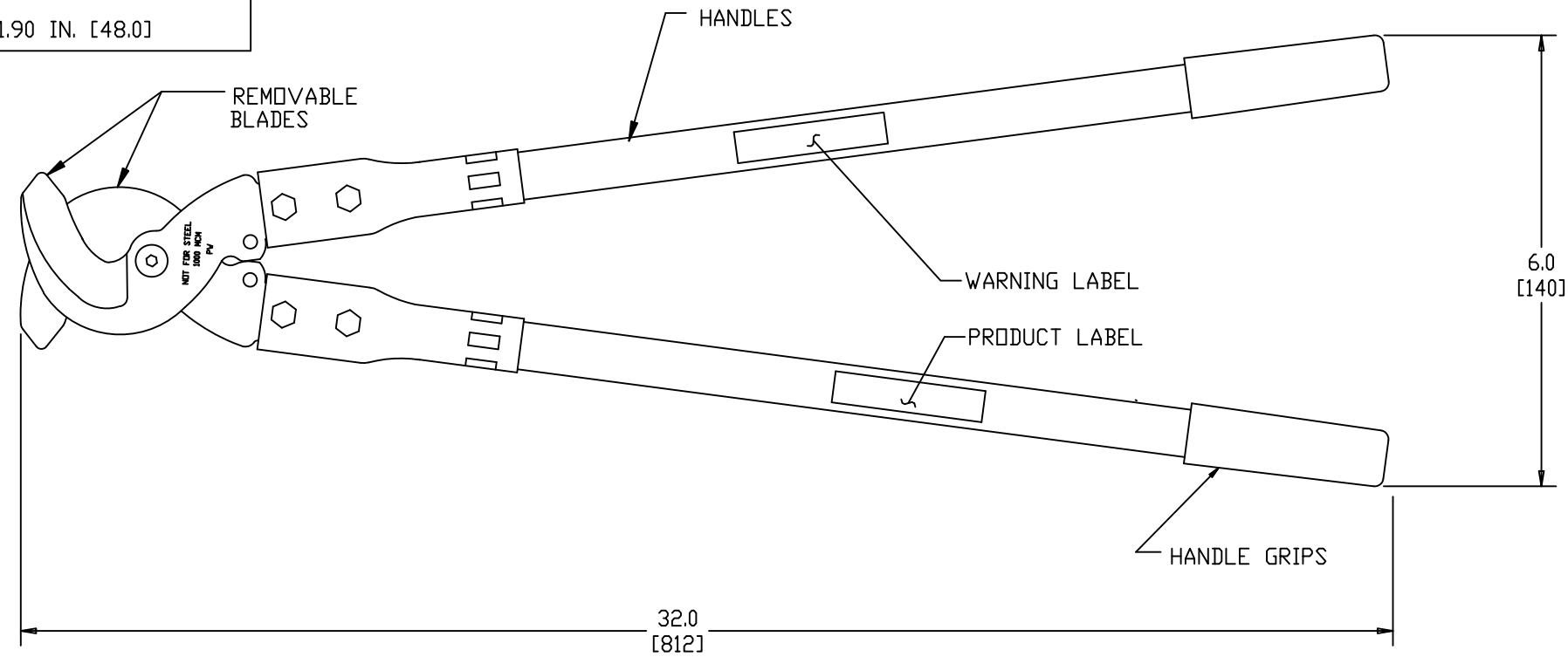

NOTES:

READ AND FOLLOW ALL INSTRUCTIONS PROVIDED BY THE OPERATOR'S MANUAL AND WARNING LABELS BEFORE USING THIS TOOL.

DIMENSIONS IN [] ARE IN MILLIMETERS ROUNDED OFF TO THE NEAREST MILLIMETER, UNLESS OTHERWISE SPECIFIED. METRIC DIMENSIONS ARE FOR REFERENCE ONLY.

SPECIFICATIONS

WEIGHT: 9.0 LBS. [4.0 KG].

JAWS:
PATENTED HIGH STRENGTH STEEL, AND REPLACEABLE (CAT. NO.: MCC1000BLADESET. INCLUDES TWO BLADES), YIELDING MINIMUM CONDUCTOR DISTORTION.

HANDLES:
FIBERGLASS WITH COMFORT GRIP DESIGN AND ERGONOMIC HANDLE ENDS PROVIDES A POSITIVE ANTI-SLIP GRIP.

FIBERGLASS HANDLE MATERIAL MEETS OR EXCEEDS ASTM F711. (100 kv/ft. DIELECTRIC STRENGTH)

TO ORDER BURNDY® PRODUCTS CALL
UNITED STATES:
1-800-346-4175 (LONDONDERRY, NH)
CANADA:
1-800-361-6975 (QUEBEC)
1-800-387-6487 (ALL OTHER PROVINCES)
FOR PRODUCT INFO: <http://www.burndy.com>

MANUAL CABLE CUTTER TOOL

ITEM NO: ---		<table border="1"> <tr> <th>DRAWING NO</th> <th>REV</th> </tr> <tr> <td>SE211277</td> <td>A</td> </tr> <tr> <td colspan="2">SHEET 1 OF 1</td> </tr> </table>	DRAWING NO	REV	SE211277	A	SHEET 1 OF 1	
DRAWING NO			REV					
SE211277			A					
SHEET 1 OF 1								
CAT NO: MCC1000								
SCALE: NTS								
DRAWN BY: D. DOBRINSKI 03/18/98								
CHECKER: D. DOBRINSKI 03/18/98								
DSN APPVL: G. HESKEY 03/04/98								
MFG APPVL: S. GRAY 03/04/98								
QC APPVL: B. HARDGROVE 03/04/98								
MKT APPVL: ---								
PROD FAM: ---								
PROJECT #: ---	SIZE							
DOCUMENT TYPE: Sales	D							
REL LEVEL: AutoCAD								