

REV	DATE	DESCRIPTION	ECO	BY	C'H'K.
B	02/01/2016 09:30:00 AM	NOTE 9 ADDED	41185	BSB	RG

CATALOG. NO.	CONDUCTOR		BOLT SIZE	FIG. NO.	DIMENSIONS										INSTALLATION TOOLING (# CRIMPS)												
	CODE (AWG)	NAVY			B	C	E	H	K DIA.	L	N	O.D.	T REF.	Y MIN.	DIE INDEX	COLOR CODE	MECHANICAL			HYDRAULIC				DIELESS (# CRIMPS)	WIRE STRIP LENGTH		
					±.06	±.04	±.02	MAX.	±.02	±.09	±.04	±.01					MD7-34R MD6	OUR840	Y8MRB-1 Y2MR	BC1500 Y500CT	Y750 Y35, BAT35 Y39, BAT750	Y46	Y45				
YAZ8C2TC10	#8 AWG [10mm <sup>2</sup> STR]	23	#10 [M5]	1	.75 [19]	.41 [10]		----	.21 [5]	2.07 [52]	.25 [6]	.27 [7]	.08 [2]		49	RED			RED (2)						MECHANICAL: MY29-11 (1)	7/8	
YAZ8C2TC1045				2		.62 [16]	.91 [23]			2.00 [51]									W8CRT (2)		U8CRT (2)	U8CRT (2)	U8CRT (2)				
YAZ8C2TC1090				3			1.00 [25]			1.37 [35]										W8CRT (2)		U8CRT (2)	U8CRT (2)	U8CRT (2)			
YAZ8C2TC10E2				1			----			2.19 [56]										W8CVT (2)		U8CRT (2)	U8CRT (2)	U8CRT (2)			
YAZ8C2TC10E245				2	#10 [M5]		.75 [19]	.91 [23]			2.12 [54]					1.03 [26]				W8CVT (2)		U8CRT (2)	U8CRT (2)	U8CRT (2)			
YAZ8C2TC10E290	#8 AWG [10mm <sup>2</sup> STR]	23	#10 [M5]	3	.75 [19]	.41 [10]			.21 [5]	1.50 [38]	.25 [6]	.27 [7]	.08 [2]	49	RED			RED (2)	X8CRT (2)	U8CRT (2)	U8CRT (2)	U8CRT (2)		7/8			

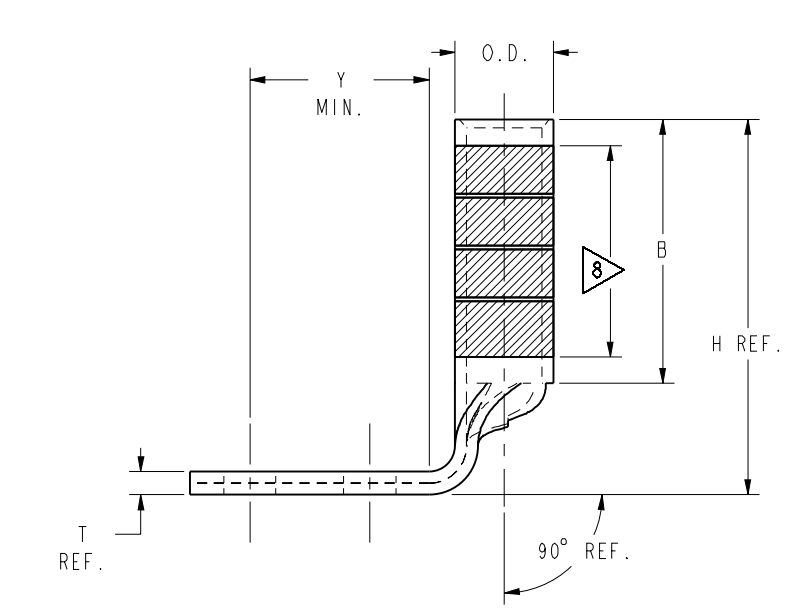
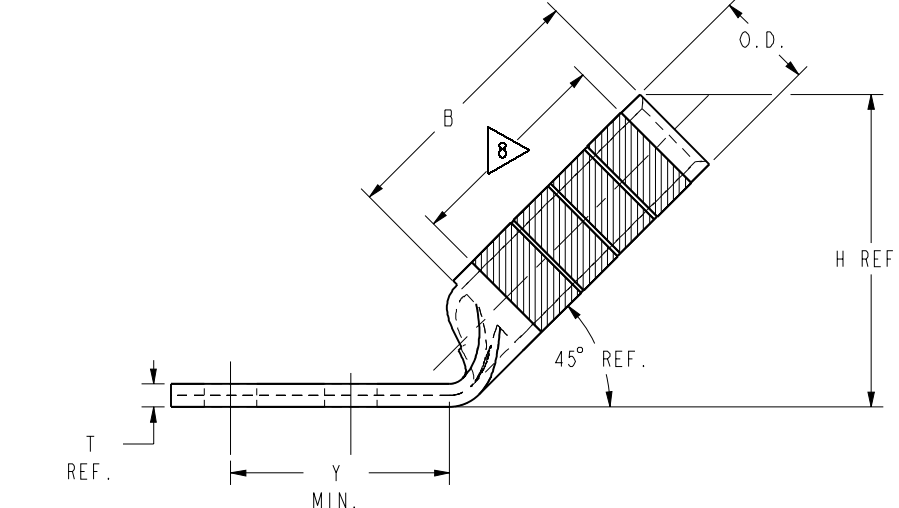
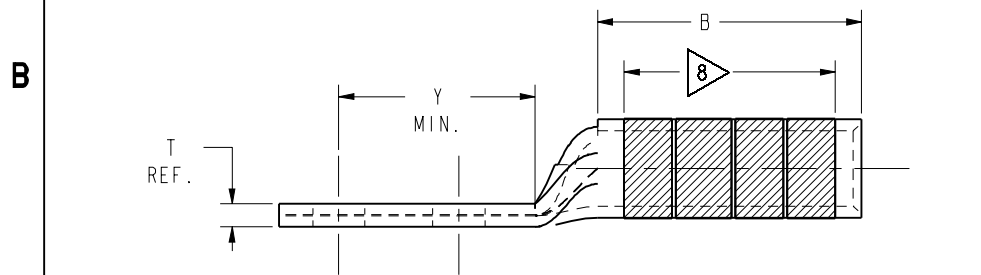
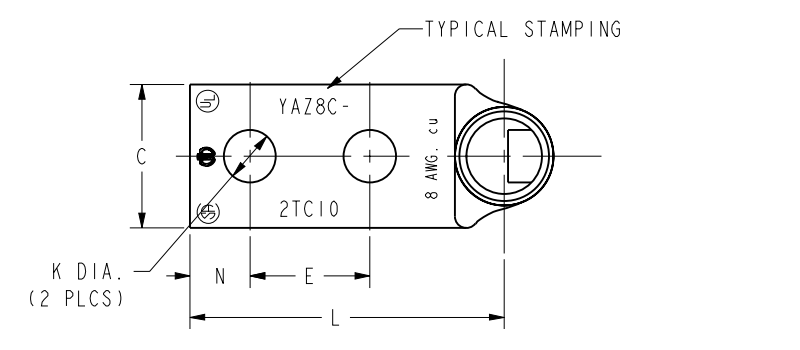
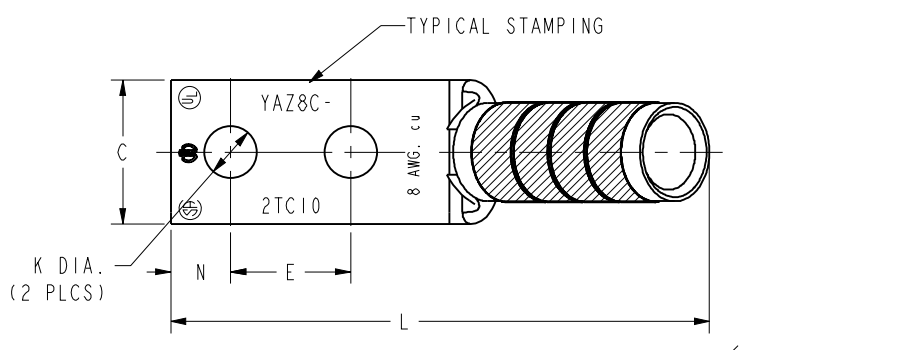
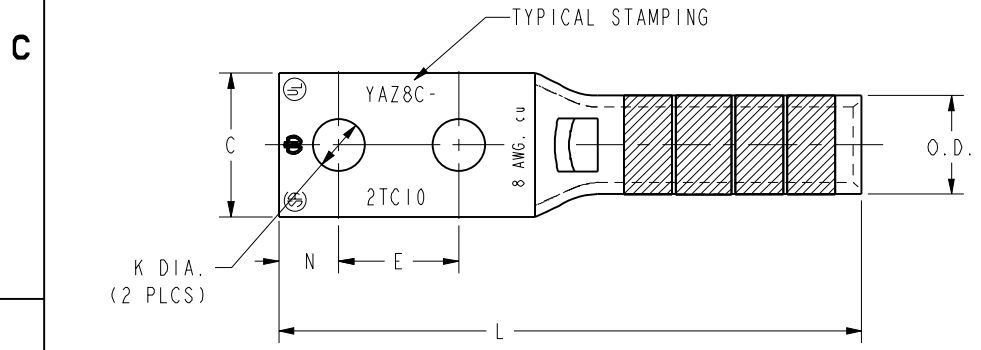

- NOTES:
- MATERIAL: COPPER TUBING.
  - FINISH: TIN PLATED
  - CATALOG # PT6515 ADAPTOR IS REQUIRED TO USE "U" DIES IN Y45 SERIES TOOLS.
  - CATALOG # PUADP-1 ADAPTOR IS REQUIRED TO USE "U" DIES IN Y46 SERIES TOOLS.
  - NAVY CABLE SIZE MAY BE OMITTED ON SOME SIZES BECAUSE OF SPACE LIMITATIONS.
  - PERMANENT DIE IN TOOLING.
  - DIMENSIONS, METRIC WIRE, & METRIC BOLT SIZES IN BRACKETS [ ] ARE IN MILLIMETERS. DIMENSIONS ARE ROUNDED OFF TO THE NEAREST MILLIMETER, UNLESS OTHERWISE NOTED, AND ARE FOR REFERENCE ONLY.
  - OVERLAP 2 CRIMPS AS NEEDED WITHIN THE LENGTH BETWEEN THE INK STAMPED CRIMPING AREA.
  - THESE CATALOG NUMBERS CANNOT BE INSTALLED WITH U8CRT DIE.

TO ORDER BURNDY® PRODUCTS CALL		HYLUG™ (TWO HOLE CODE)	
UNITED STATES 1-800-346-4175 (LONDONDERRY, NH)		ITEM NO: N/A	CAT. NO: YAZ8C-2TC- (TABLE)
CANADA: 1-800-361-6975 (QUEBEC) 1-800-387-6487 (ALL OTHER PROVINCES)		DRAWN BY: D. BOISVERT 11/10/98	CHECKER: K. HENRY 12/03/98
FOR PRODUCT INFO: <a href="http://www.burndy.com">http://www.burndy.com</a>		DSN APPVL: B. MACDONALD 12/02/98	MFG APPVL: N/A
		GA APPVL: S. GARY 11/30/98	MKT APPVL: B. HARGROVE 11/25/98
		PROD FAM: --	SCALE: 4:1
		PROJECT #: --	DRAWING NO: SE211915
		DOCUMENT TYPE: Sales	REV: B
		REL LEVEL: Released	SHEET 2 OF 36