

DRAWING NO.
SE212273

7

6

5

4

3

2

1

REV	DATE	DESCRIPTION	ECO	BY	C'H'K.
C	07/19/2016 00:00:00 AM	CONDUCTOR SIZE UPDATED IN TABLE	44415	DD	NJS

CATALOG NO.	CONDUCTOR		BOLT SIZE	FIG. NO.	DIMENSIONS										INSTALLATION TOOLING (# CRIMPS)											
	FLEX	CODE (AWG)			B	C	E	H REF.	K DIA.	L	N	O.D.	T REF.	Y MIN.	DIE INDEX	COLOR CODE	MECHANICAL			HYDRAULIC			DIELESS (# CRIMPS)	WIRE STRIP LENGTH		
																	MD7-34R	OUR840	BCT500 Y500CT	Y750 Y35 Y39	Y46	Y45				
YAZV272TC14FX	3/0 AWG CLASS G, H I, K, M DLO (450/24)	3/0 AWG CLASS B, C 95mm ² CLASS 5	1/4 [M6]	1	1.50 [38]	1.03 [26]	.62 [16]	---	.27 [7]	3.23 [82]	.31 [8]	.70 [18]	.14 [4]	.96 [24]	14	ORANGE	6	6	6	6	6	6	MECHANICAL: MY29-11 (1) HYDRAULIC: Y644, Y644M Y644MBH, (1)	1-9/16		
YAZV272TC14FX45				2	1.84 [47]			2.96 [75]		14					ORANGE	6	6	6	6							
YAZV272TC14FX90				3	2.16 [55]			1.69 [43]		14					ORANGE	6	6	6	6							
YAZV272TC14E2FX				1	---	3.36 [85]	.31 [8]	.70 [18]	.14 [4]	1.09 [28]	14	ORANGE	W27VT X27RT W27RT (4)	X27RT W27VT (4)	W27VT X27RT W27RT (4)	U27RT (2)	U27RT (2)	U27RT (2)								
YAZV272TC14E2FX45				2	1.84 [47]	3.08 [78]													14	ORANGE	6	6			6	6
YAZV272TC14E2FX90				3	2.16 [55]	1.82 [46]													14	ORANGE	6	6			6	6

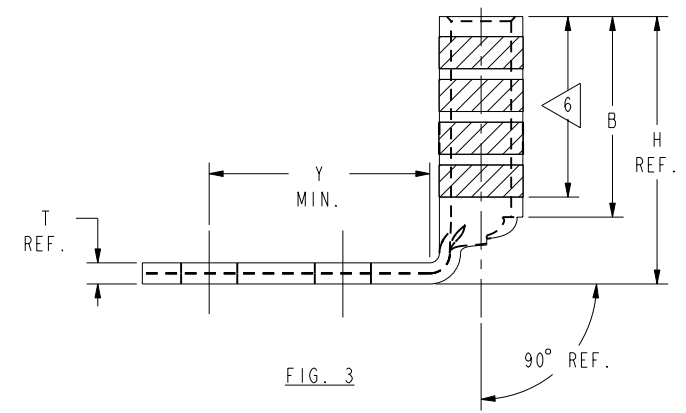
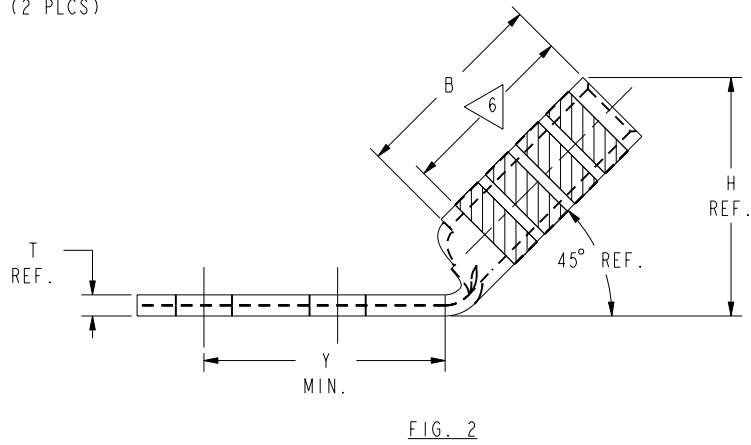
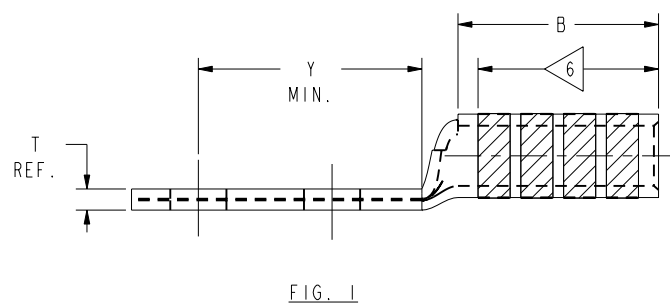
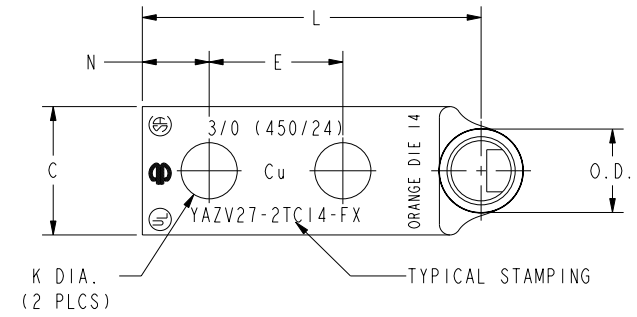
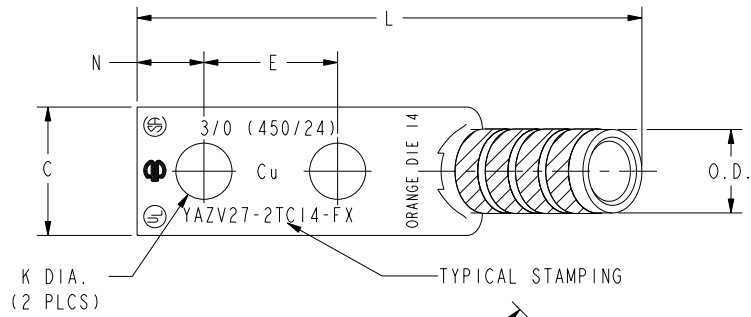
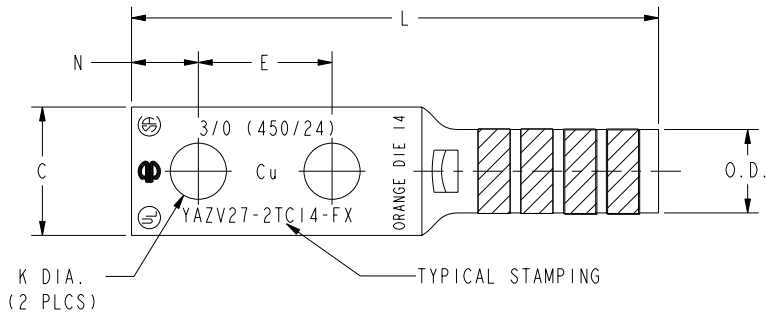

NOTES:

- MATERIAL: COPPER TUBING.
- FINISH: TIN PLATED.
- CATALOG # PT6515 ADAPTOR IS REQUIRED TO USE "U" DIES IN Y45 SERIES TOOLS.
- CATALOG # PUADP-1 ADAPTOR IS REQUIRED TO USE "U" DIES IN Y46 SERIES TOOLS.
- DIMENSIONS IN BRACKETS [] ARE IN MILLIMETERS ROUNDED OFF TO THE NEAREST MILLIMETER, UNLESS OTHERWISE NOTED, AND ARE FOR REFERENCE ONLY.
- CRIMP (# OF CRIMPS PER TABLE) WITHIN THE LENGTH BETWEEN THE INK STAMPED CRIMPING AREA.

TO ORDER BURNDY® PRODUCTS CALL		HYLUG™ (TWO HOLE FLEX)	
UNITED STATES 1-800-346-4175 (LONDONDERRY, NH)		ITEM NO: N/A	CAT. NO: YAZV27- (TABLE)
CANADA: 1-800-361-6975 (QUEBEC) 1-800-387-6487 (ALL OTHER PROVINCES)		DRAWN BY: B MICHAUD 8/25/99	CHECKER: K HENRY 8/26/99
FOR PRODUCT INFO: http://www.burndy.com		DSN APPVL: RR TEAM 9/28/99	MFG APPVL: --
		QA APPVL: J BRODEUR 10/6/99	MKT APPVL: R ROBICHEAU 10/5/99
		PROJ #: --	SCALE: NTS
		SIZE: D	DRAWING NO: SE212273
		DOCUMENT TYPE: Sales	REV: C
		REL LEVEL: Released	SHEET 27 OF 48

REV: PE0200

8

7

6

5

4

3

2

1