

REV	DATE	DESCRIPTION	ECO	BY	C'H'K.
C	01/20/2014 00:00:00 AM	BOLT SIZE MODIFIED ON SHEET NO. 44	34686	BSB	MA

CATALOG NO.	CONDUCTOR		BOLT SIZE	FIG. NO.	DIMENSIONS										INSTALLATION TOOLING (# CRIMPS)							
	FLEX	CODE (AWG)			B ±.09	C ±.06	E ±.02	H REF.	K DIA. ±.02	L ±.15	N ±.06	O.D. ±.01	T REF.	Y MIN.	DIE INDEX	COLOR CODE	HYDRAULIC			DIELESS (# CRIMPS)	WIRE STRIP LENGTH	
																	Y750 Y35, BAT35 Y39, BAT750	Y46 ◁ 4	Y45 ◁ 3			
YAZ402TC38FX	646 kcmil 1600/24 600 kcmil FLEX	---	3/8 [M10]	1	2.94 [75]	1.98 [50]	1.00 [25]	---	.40 [10]	.50 [13]	1.35 [34]	.30 [8]	1.43 [36]	24	BLACK	◁ 7	◁ 7	◁ 7	HYDRAULIC: Y644, Y644M Y644MBH, (1)	3		
YAZ402TC38FX45				2				3.78 [96]								6.89 [175]	6.89 [175]	U39RT (4)			U39RT (4)	U39RT (4)
YAZ402TC38FX90				3				4.40 [112]								6.89 [175]	6.89 [175]	U39RT (4)			U39RT (4)	U39RT (4)
YAZ402NNTFX	646 kcmil 1600/24 600 kcmil FLEX	---	1/2 [M12]	1	2.94 [75]	1.63 [41]	1.75 [44]	---	.56 [14]	.62 [16]	1.35 [34]	.30 [8]	2.40 [61]	24	BLACK	U39RT (4)	U39RT (4)	U39RT (4)	HYDRAULIC: Y644, Y644M Y644MBH, (1)	3		
YAZ402NNTFX45				2				3.78 [96]								6.89 [175]	6.89 [175]	U39RT (4)			U39RT (4)	U39RT (4)
YAZ402NNTFX90				3				4.40 [112]								6.89 [175]	6.89 [175]	U39RT (4)			U39RT (4)	U39RT (4)

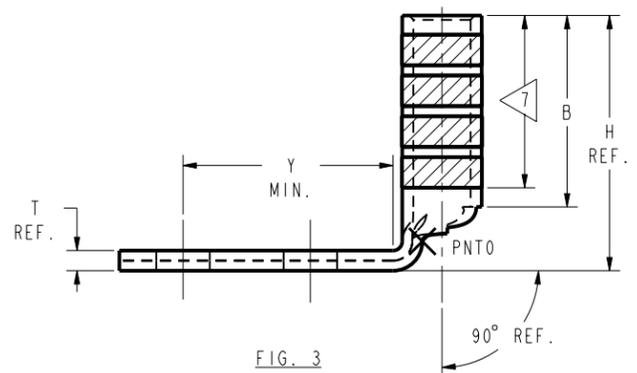
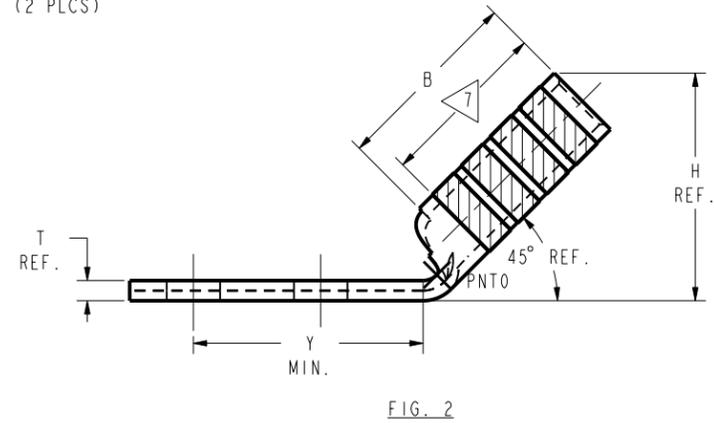
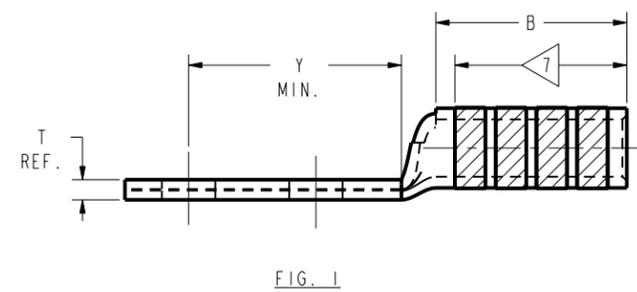
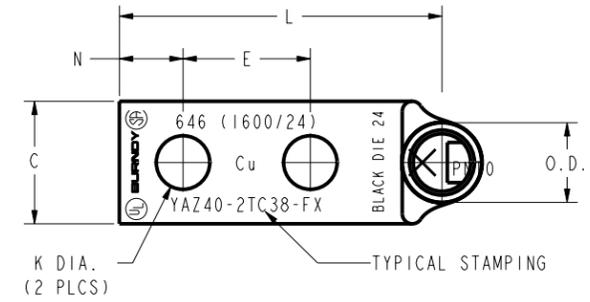
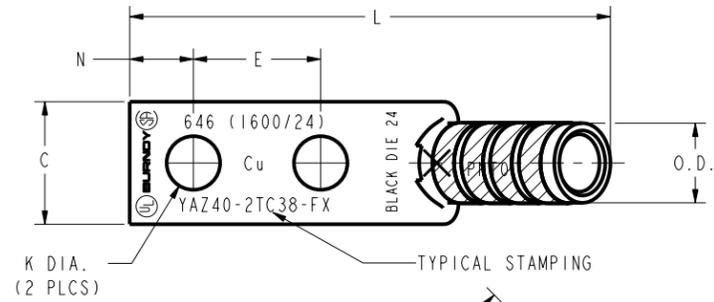
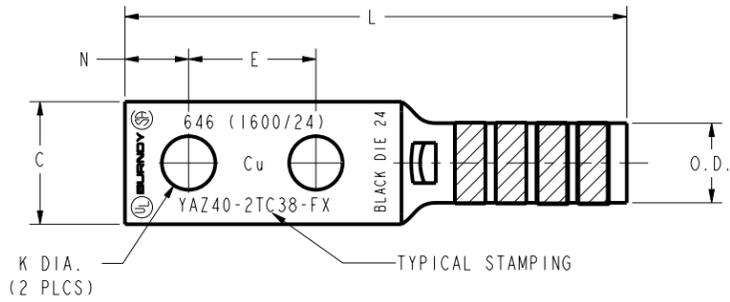

NOTES:

- MATERIAL: COPPER TUBING.
- FINISH: TIN PLATED.
- ◁ 3 CATALOG # PT6515 ADAPTOR IS REQUIRED TO USE "U" DIES IN Y45 SERIES TOOLS.
- ◁ 4 CATALOG # PUADP-1 ADAPTOR IS REQUIRED TO USE "U" DIES IN Y46 SERIES TOOLS.
- ◁ 5 PERMANENT DIE IN TOOLING.
- DIMENSIONS IN BRACKETS [ ] ARE IN MILLIMETERS ROUNDED OFF TO THE NEAREST MILLIMETER, UNLESS OTHERWISE NOTED, AND ARE FOR REFERENCE ONLY.
- ◁ 7 CRIMP (# OF CRIMPS PER TABLE) WITHIN THE LENGTH BETWEEN THE INK STAMPED CRIMPING AREA.

TO ORDER BURNDY® PRODUCTS CALL  UNITED STATES 1-800-346-4175 (LONDONDERRY, NH)  CANADA: 1-800-361-6975 (QUEBEC) 1-800-387-6487 (ALL OTHER PROVINCES)  FOR PRODUCT INFO: <a href="http://www.burndy.com">http://www.burndy.com</a>	HYLUG™ (TWO HOLE FLEX)	
	ITEM NO:	N/A
	CAT. NO:	YAZ40--- (TABLE)
	DRAWN BY:	B MICHAUD 8/25/99
	CHECKER:	D BOISVERT 8/26/99
	DSN APPVL:	RR TEAM 9/28/99
	MFG APPVL:	---
	QA APPVL:	J BRODEUR 10/6/99
	MKT APPVL:	R ROBICHEAU 10/5/99
	PROD FAM:	---
PROJECT #:	---	
DOCUMENT TYPE:	Sales	
REL LEVEL:	Released	
SCALE:	NTS	
DRAWING NO:	SE212273	
REV:	C	
SHEET:	44 OF 48	

REV: PE0200