

TRANSFORMER SPECIFICATIONS	
PRIMARY VOLTAGE(S)	230/400/460/575
SECONDARY VOLTAGE(S)	95/115/125
RATED V.A.	3000
RATED FREQUENCY	50/60
INSULATION CLASS	180°C @ MAX RISE 115°C
AGENCY APPROVALS	UL, CUL
ESTIMATED WEIGHT	89 LBS

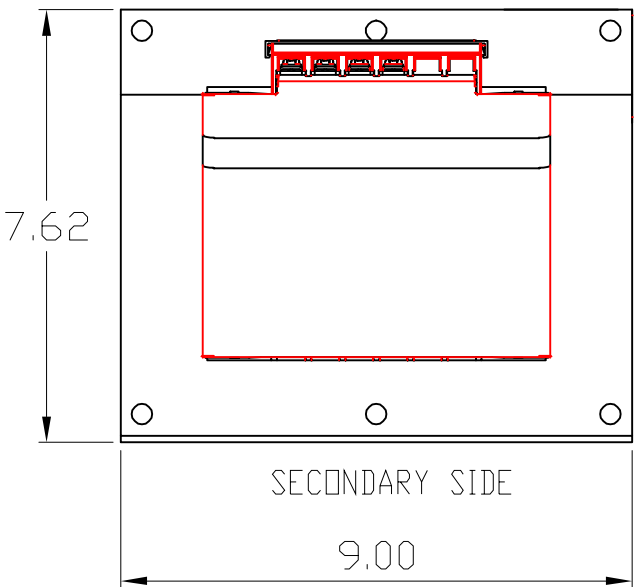

SECONDARY SIDE

PRIMARY SIDE

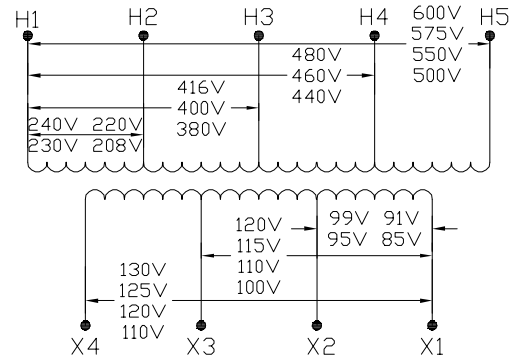
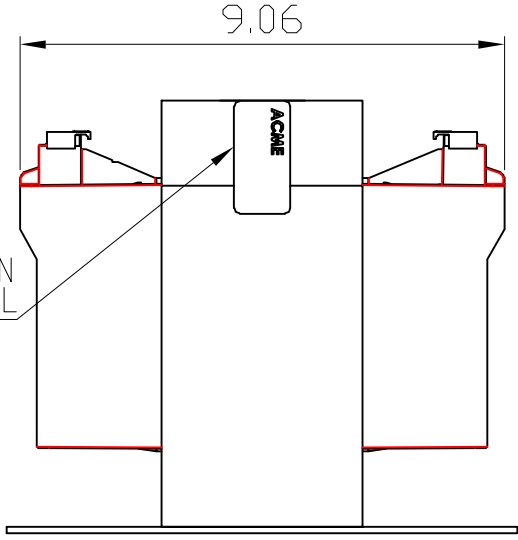

CONNECTION DIAGRAM

DIMENSIONS ARE IN INCHES TOLERANCES: .XX ± .03 .XXX ± .010 ANGULAR: ± 1°	NAME	DATE	
	DRAWN BY: VS	08/06/2020	
SOURCE	PROPRIETARY AND CONFIDENTIAL THE INFORMATION CONTAINED IN THIS DRAWING IS THE SOLE PROPERTY OF ACME ELECTRIC. ANY REPRODUCTION IN PART OR AS A WHOLE WITHOUT THE WRITTEN PERMISSION OF ACME ELECTRIC IS PROHIBITED.		
MATERIAL			
FINISH			DESCRIPTION:
DO NOT SCALE DRAWING			3000 VA
	SIZE DWG. NO.	TB3000N007	
	WEIGHT:	LBS.	SHEET 1 OF 1