

S.NO	CATALOG NUMBER	L
1	SBA15-50HD	1.50 [38]
2	SBA17-50HD	1.75 [44]
3	SBA20-50HD	2.00 [51]
4	SBA225-50HD	2.25 [57]
5	SBA25-50HD	2.50 [64]
6	SBA30-50HD	3.00 [76]
7	SBA35-50HD	3.50 [89]
8	SBA40-50HD	4.00 [102]

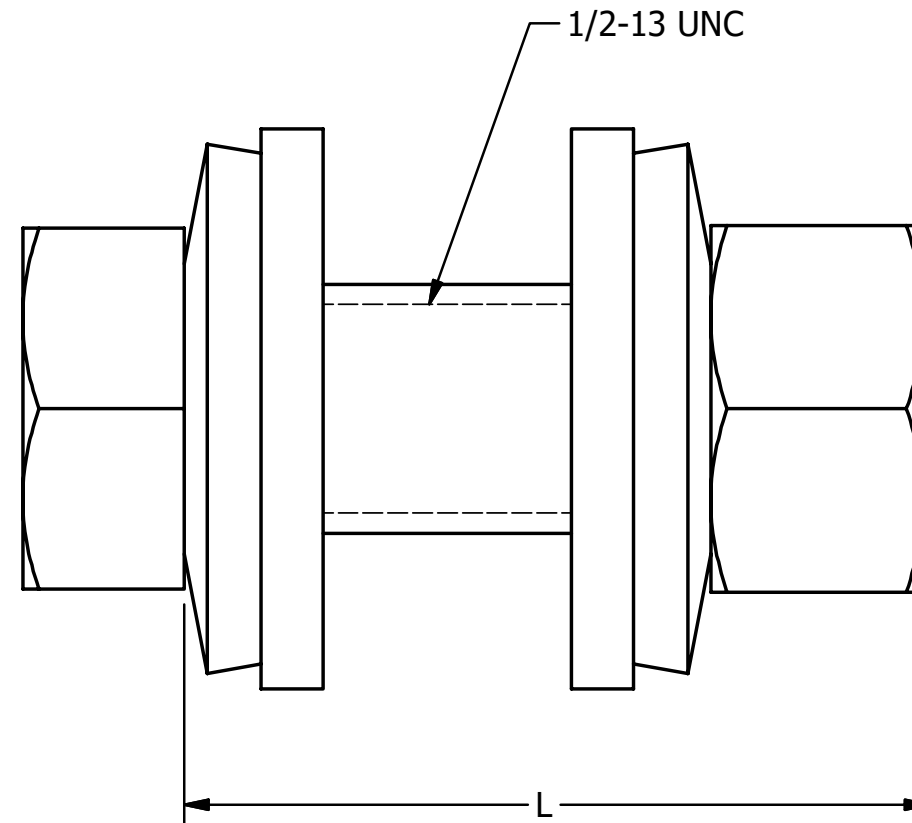

					TO ORDER CMC PRODUCTS CALL 1-513-860-4455  FOR PRODUCT INFO: <a href="http://www.cmclugs.com">http://www.cmclugs.com</a>	DRAWN BY: <b>TS</b> 12/18/18	NAME OF PART: <b>BOLT ASSEMBLY</b>	CAT. NO.: <b>SEE TABLE</b>
						CHECKED BY:	DWG NO: <b>U08492008HD-S (CHARTED)</b>	<b>A</b>
<b>A</b>	NEW DRAWING CREATED		12/18/18	TS		DRAWING NOT TO SCALE		SHEET NO: 1 OF 1
REV.	DESCRIPTION	ECN	DATE	INIT.				

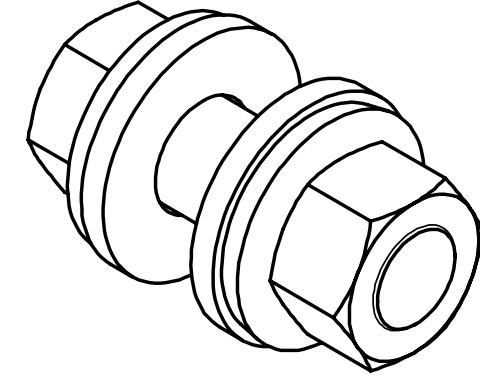