

M-8601

6

LIST OF PARTS

DESCRIPTION	MATERIAL	FINISH
BOX	STEEL .0625 THK	PRE-GALV.
FL. HD. ADJ. SCREW	STEEL	ZINC PL.
RD. HD. MTG. SCREW	STEEL	ZINC PL.
HOLD DOWN	ALUMINUM	
HEX LOCK NUT	STEEL	ZINC PL.
COVER	STEEL	PAINTED PRE-GALV.

DIMENSION SHEET FOR CAT. NO. SEE TABLE

REPAIRABLE

NON-REPAIRABLE

B

M-8601

6

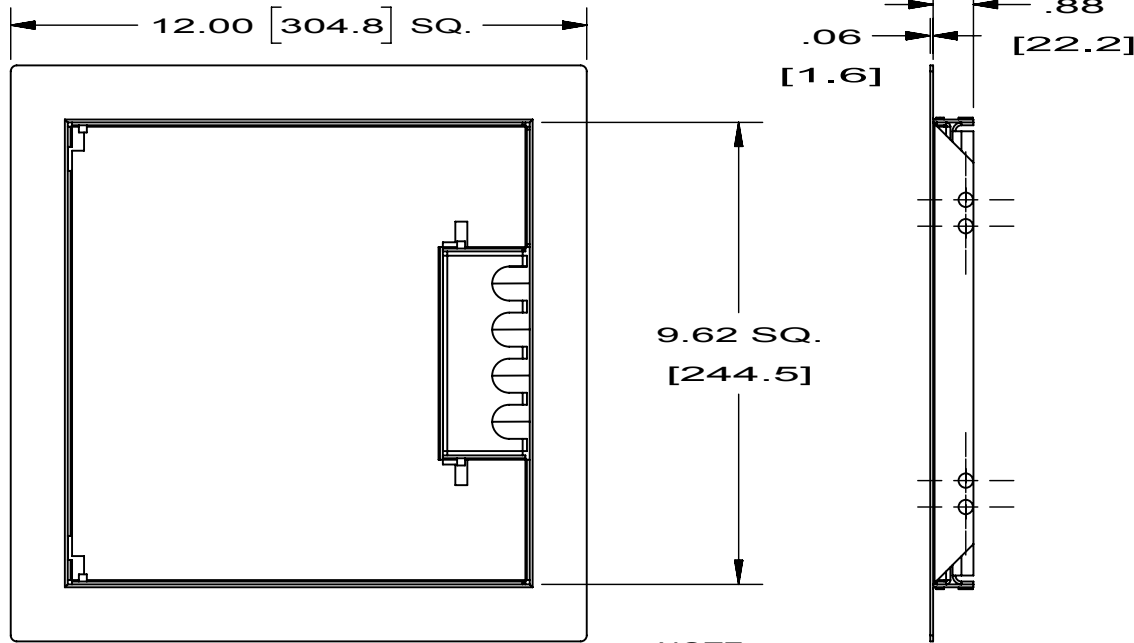

VIEW "A" COVER

NOTE:
SEE DRAWING M-8607 FOR COMPLETE COVER DIMENSIONS AND DETAILS

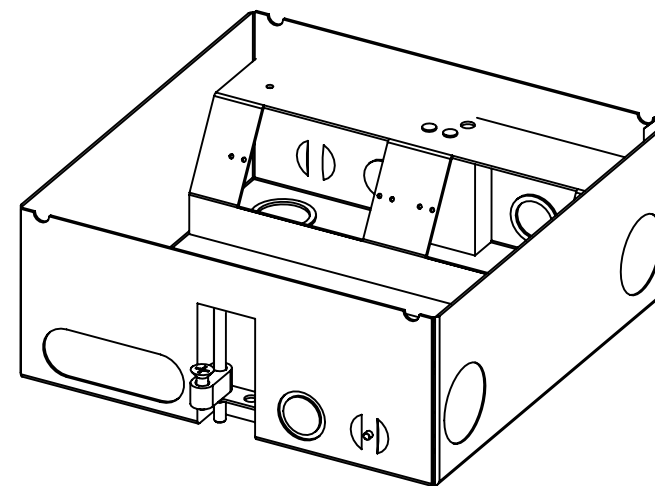
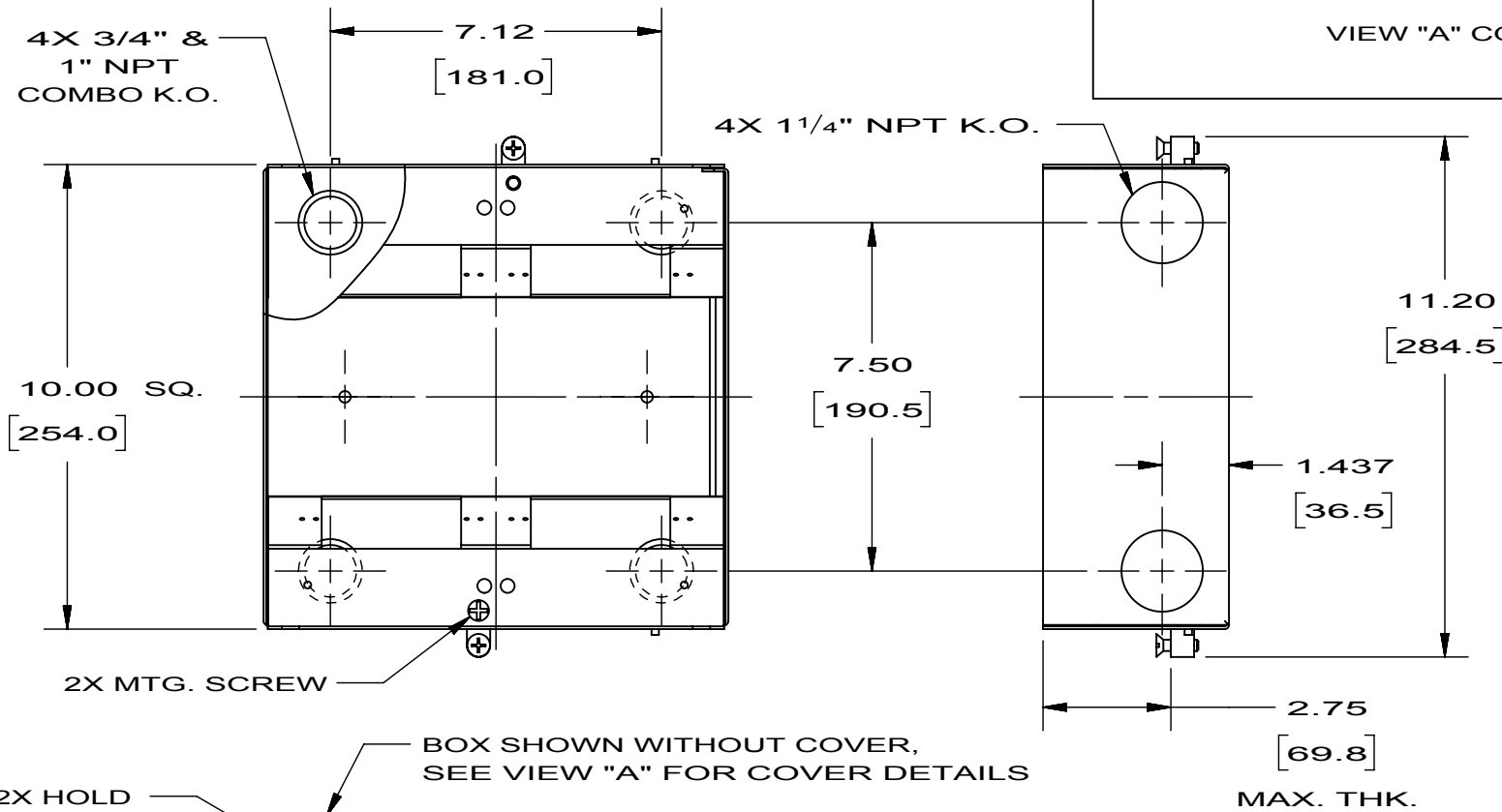
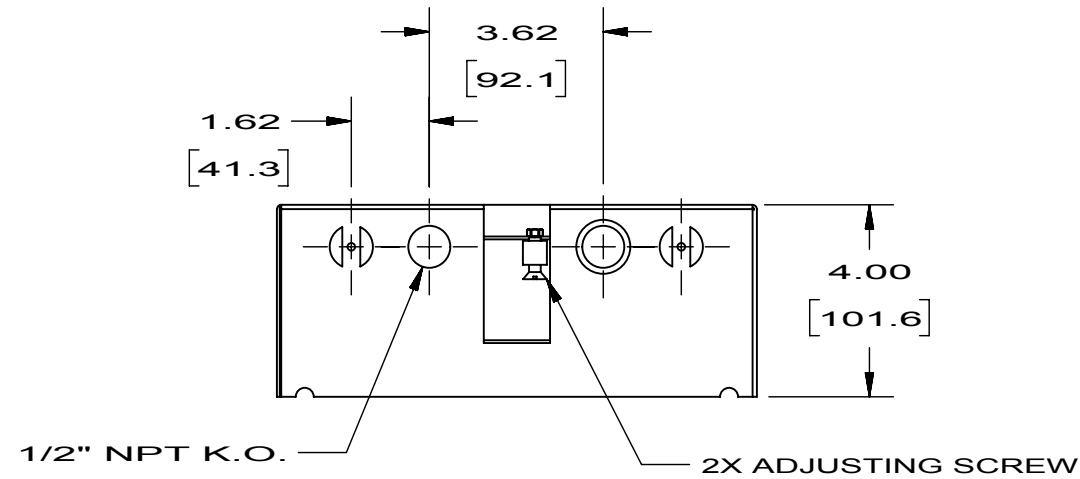

ISOMETRIC VIEW
SCALE: 1:4
(COVER NOT SHOWN)

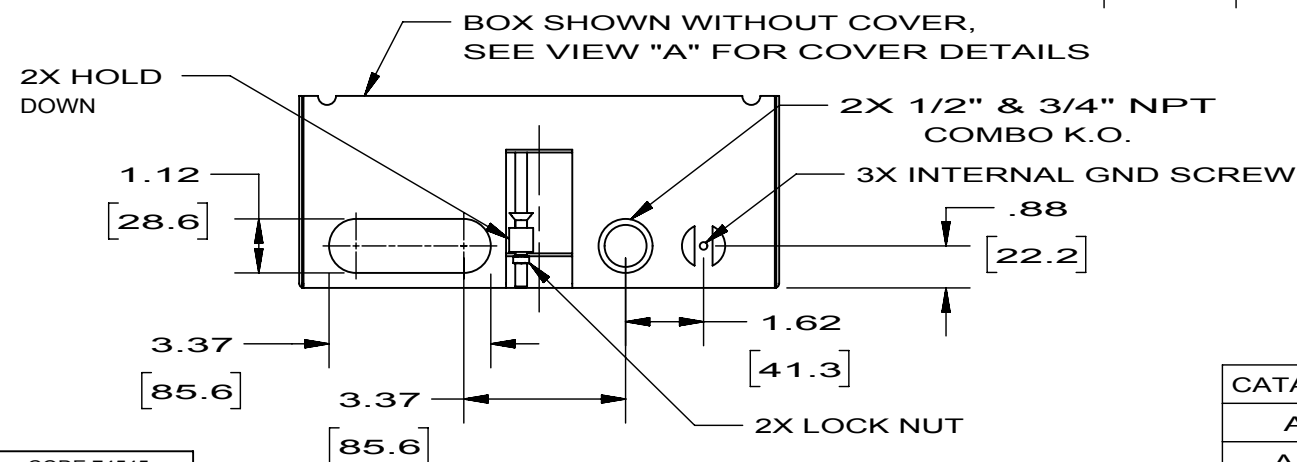

CATALOG NUMBER	COLOR OF COVER
AFB301BK	BLACK
AFB301GNT	GRANITE

DIM'S. INCHES
[MM]

SYM	REVISIONS	APP	DATE
6	COVER VIEW: 9.62 SQ [244.5] WAS [244.3], .06 [1.6] WAS [1.5], .88 [22.2] WAS .84 [21.3], ADDED NOTE, ADDED PICTORIAL VIEW OF SLOTS. PER DCN 24033 RM	DDL	5/3/18
5	ADDED ISOMETRIC VIEW; DIMS & SIDE VIEW RELOCATED; REMOVED NOTES PER DCN 14344 RCM	DJP	10/31/07
4	ADDED VIEW "A" WITH DETAILS. ADDED CALLOUT "BOX SHOWN WITHOUT COVER, SEE VIEW "A" FOR COVER DETAILS". REMOVED NOTE 4. ADDED TABLE. UPDATED TITLE. PER DCN 13324 SPN	JPP	8/14/06
3	REVISED VIEW OF BOX SHOWING NEW DESIGN: ADDED & RELOCATED K.O.'S; REMOVED NOTE 1; REVISED NOTE 4 PER DCN 13264 RCM	JPP	7/27/06
2	CHANGED KO SIZE FROM DECIMAL TO FRACTION. CHANGED NOTE-1 REMOV. HUBBELL CANADA #9171	JVD	12-18-01 PAC
1	INITIAL RELEASE #8998		9-20-01

THE DESIGN AND DIMENSIONS OF THE PRODUCT SHOWN ON THIS DRAWING ARE SUBJECT TO CHANGE WITHOUT NOTICE

TITLE
RAISED ACCESS FLOOR BOX & COVER
STAMPED STEEL, 4 GANG, DEEP

TOLERANCES UNLESS OTHERWISE SPECIFIED	WIRING DEVICE-KELLEMS HUBBELL INCORPORATED SHELTON, CT		
.XX = ± .01	DR. BY	PAC	APP. BY
.XXX = ± .005	TR. BY	JVD	SCALE 1:4
ANGLES = ± 2°	CHK. BY	JVD	DATE 9-20-01