

M-12492 1

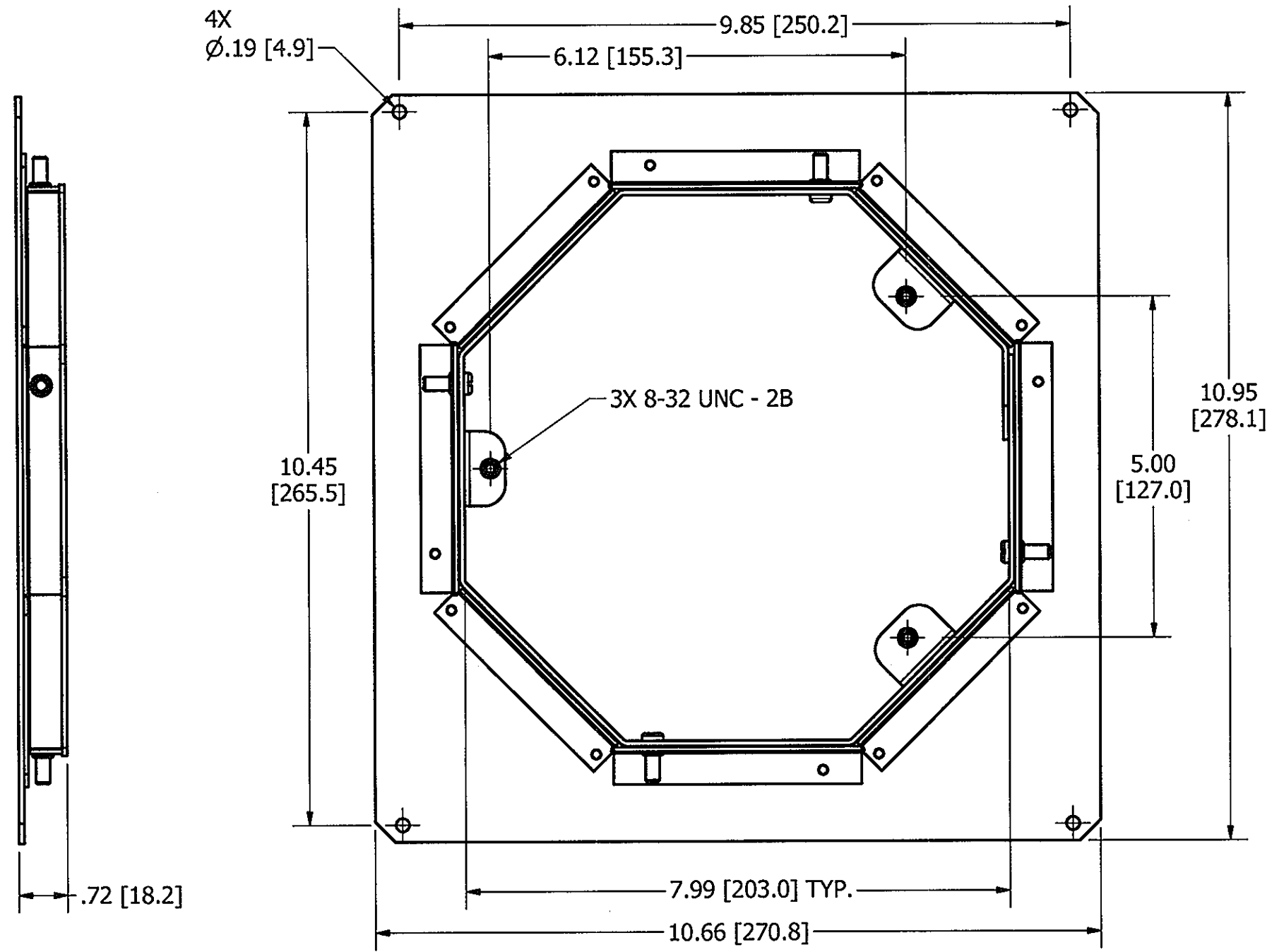

TEMPORARY CONCRETE COVER NOT SHOWN

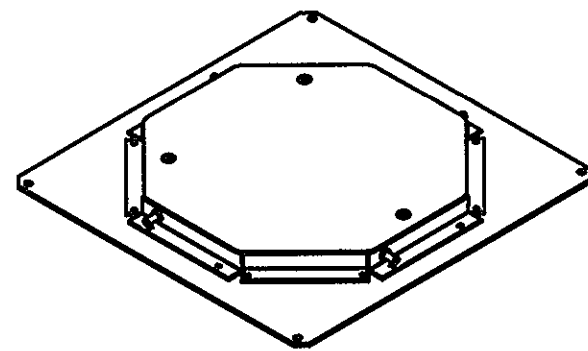

CFB4GS1R8ADAPT

- NOTES:
1. ALL DIMENSIONS ARE IN INCHES AND [MILLIMETERS].
 2. PRODUCT IS cULus LISTED. COMPLIES WITH UL 514A.
 3. USE WITH RECESSED 4-GANG CONCRETE FLOOR BOXES (CFB4Gxx), SOLD SEPARATELY.
 4. USE WITH SYSTEM 1 RECESSED 8 INCH COVERS (S1R8CVRxx), SOLD SEPARATELY.
 5. MOUNTING HARDWARE INCLUDED.

LIST OF PARTS

DESCRIPTION	MATERIAL	FINISH
ADAPTER PLATE	14 GA. STEEL	ZINC
ANGLE BRACKETS	16 GA. STEEL	ZINC
COLLAR	16 GA. STEEL	ZINC
HARDWARE	STEEL	ZINC

DIMENSION SHEET FOR CAT. NO. CFB4GS1R8ADAPT

REPAIRABLE NON-REPAIRABLE

1	INITIAL RELEASE PER DCN19233	SBW	11/15/13
SYM	DESCRIPTION	APP	DATE

THE DESIGN AND DIMENSIONS OF THE PRODUCT SHOWN ON THIS DRAWING ARE SUBJECT TO CHANGE WITHOUT NOTICE

TITLE
 ADAPTER ASSEMBLY, SYSTEM ONE
 RECESSED 8 INCH COVER TO
 RECESSED 4-GANG CONC. FLOORBOX

TOLERANCES UNLESS OTHERWISE SPECIFIED				WIRING DEVICE-KELLEMS HUBBELL INCORPORATED SHELTON, CT.			
.XX = ± .01	.XXX = ± .005	ANGLES = ± 2°	DR. BY	SBW	APP. BY	SCALE	1/2
			TR. BY	SM	DATE	9/23/2013	

B M-12492 1