

M-13863

1

CONCENTRIC KNOCKOUTS

LOCATION	QUANTITY	TRADE SIZE
ENDS	1/END	3/4", 1", 1-1/4" SEE NOTE 8
ENDS	1/END	1/2", 3/4"
SIDES	2/SIDE	1/2", 3/4", 1", 1-1/4"
BOTTOM	4	1/2", 3/4", 1", 1-1/4"

LIST OF PARTS

DESCRIPTION	MATERIAL	FINISH
BOX ASSEMBLY	16 GA. STEEL	ZINC **
TOP MOUNTING ASSY	14 GA. STEEL	ZINC
GROUND WIRES	COPPER	
WIRING CHANNEL	16 GA. STEEL	ZINC
FASTENERS	STEEL	ZINC
FLUSH TEMP COVER	16 GA. STEEL	ZINC
RAISED TEMP COVER	THERMOPLASTIC	YELLOW

** CATALOG NO. CFB2G30CR BOX ASSEMBLY IS GALVANIZED AND EPOXY COATED ON EXTERIOR SURFACE.

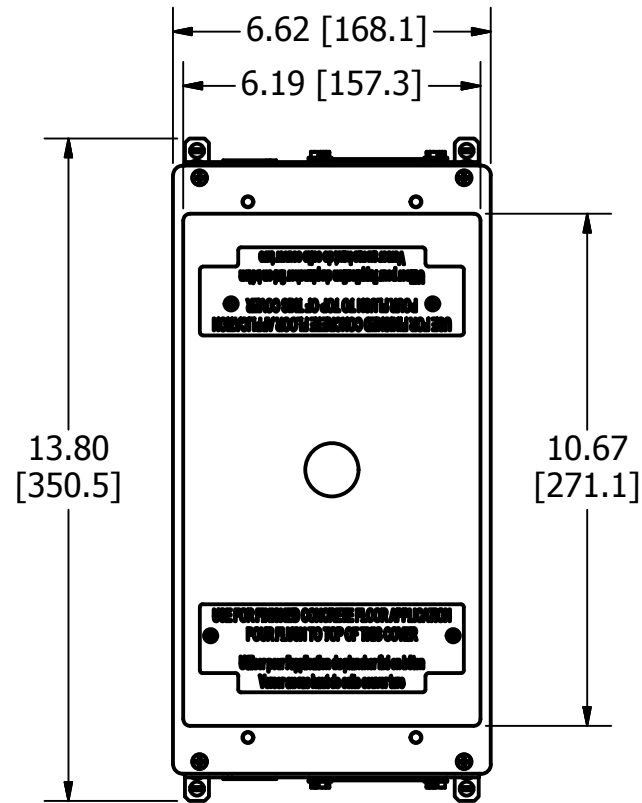

TOP VIEW

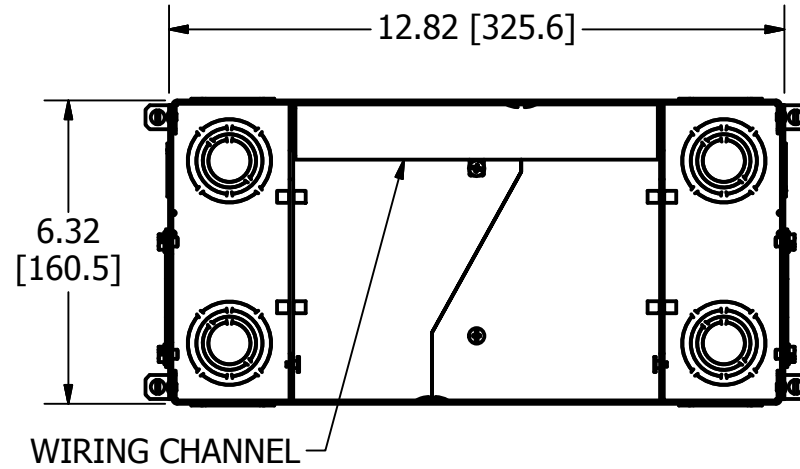

SECTION A-A
VIEW THROUGH BOX BELOW TRANSITION

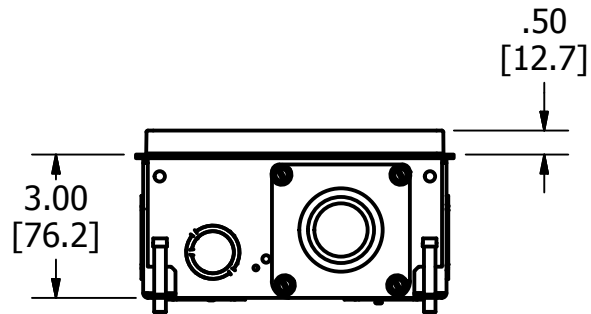

END VIEW

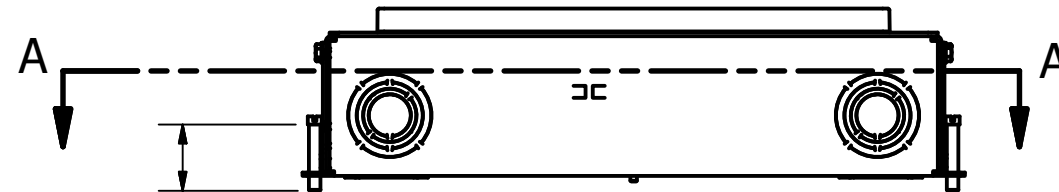

4X 1.38 [35.1]
LEVELING SCREW

SIDE VIEW

NOTES:

1. ALL DIMENSIONS ARE IN INCHES AND [MILLIMETERS].
2. PRODUCT IS cULus LISTED. COMPLIES WITH UL 514A.
3. EACH GANG SUPPLIED WITH 6" [152.4] 12 GA. AWG GROUND PIGTAIL.
4. MINIMUM CONCRETE POUR: 3.00" [76.2].
5. WIRING CHAMBER VOLUMES (RECESSED COVER) : (2) 35 IN³ [573.6 CM³].
6. WIRING CHANNEL AREA: .83 IN² [535 MM²].
7. WIRING CHAMBER VOLUMES (FURNITURE FEED) : (2) 90 IN³ [1474.9 CM³].
8. 2" TRADE SIZE CONDUIT HUBS (CFBHUB2) MAY BE USED IN PLACE OF KO PLATES, SOLD SEPARATELY.

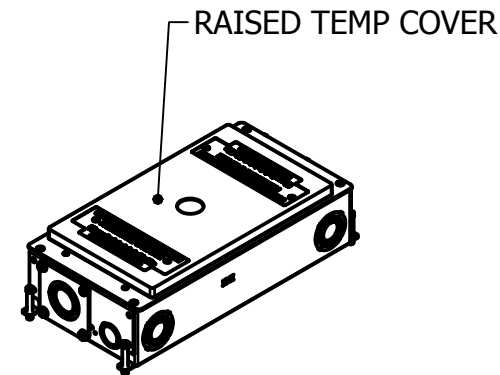

ISOMETRIC

1	RELEASED PER DCN 23642	SBW	3/19/18
REV	DESCRIPTION	APP	DATE

THE DESIGN AND DIMENSIONS OF THE PRODUCT SHOWN ON THIS DRAWING ARE SUBJECT TO CHANGE WITHOUT NOTICE. DIMENSIONS ARE IN INCHES [mm].

TITLE
CONCRETE FLOOR BOX, 2 GANG FOR RECTANGULAR COVER, DEEP

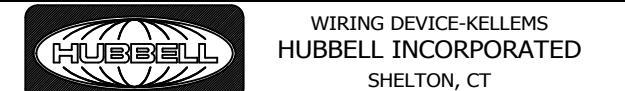

TOLERANCES UNLESS OTHERWISE SPECIFIED .XX = ± .01 .XXX = ± .005 ANGLE TOL. ±2'	DR. BY SBW	SCALE 1/4
	CHK. BY	DATE 3/5/2018

DIMENSION SHEET FOR CAT. NO. CFB2G30, CFB2G30CR

B

M-13863

1