

CFB4G25 / CFB4G30  
(RECTANGULAR COVER FOR 2 1/2", 3" MIN POUR)

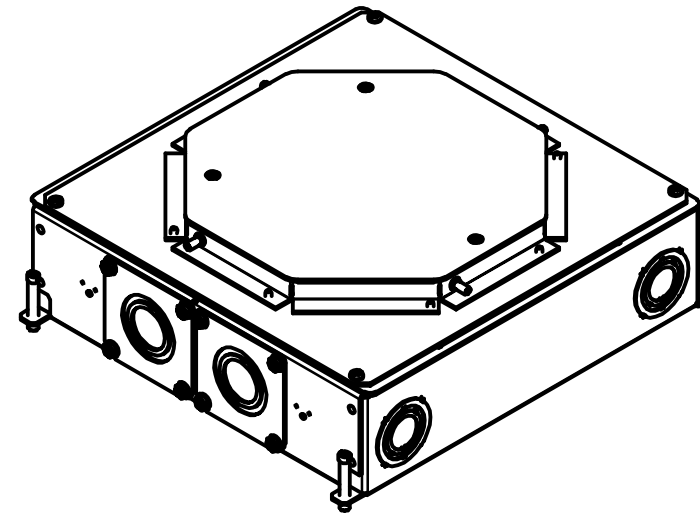

CFB4G25R / CFB4G30R  
(ROUND COVER FOR 3 1/4", 3 3/4" MIN POUR)

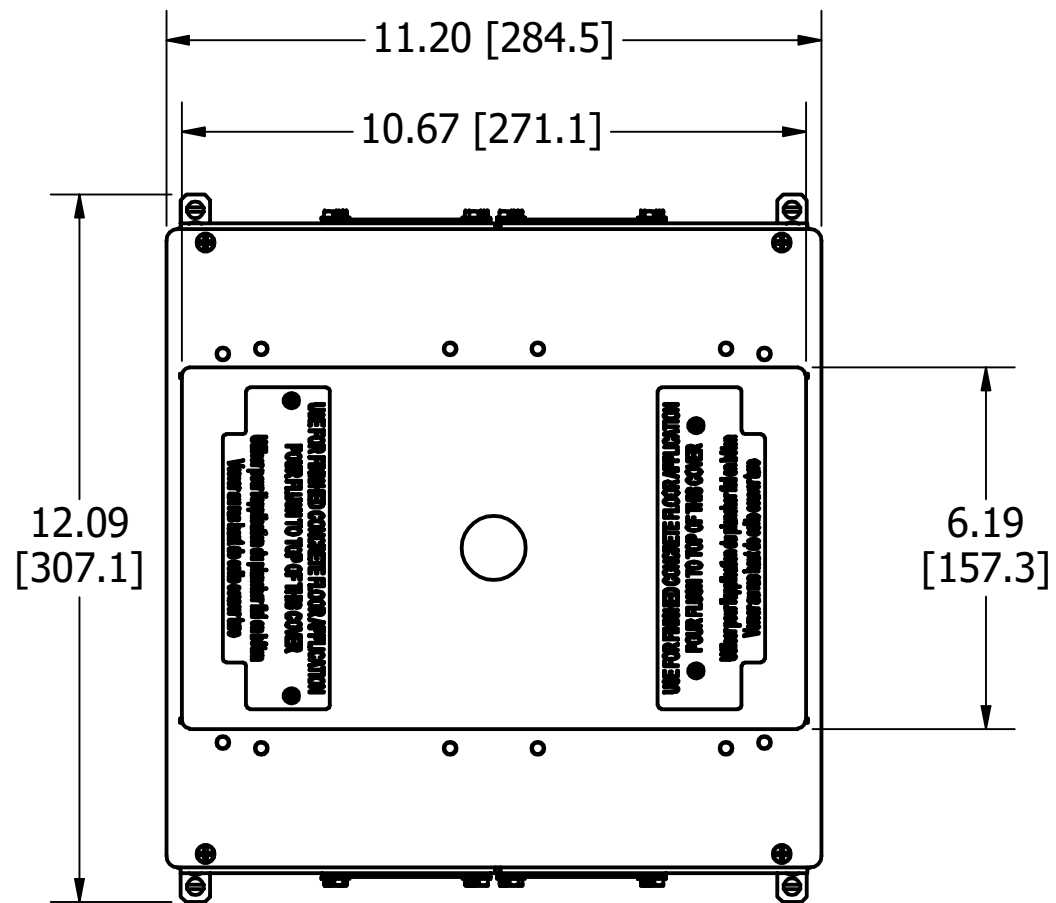

TOP VIEW

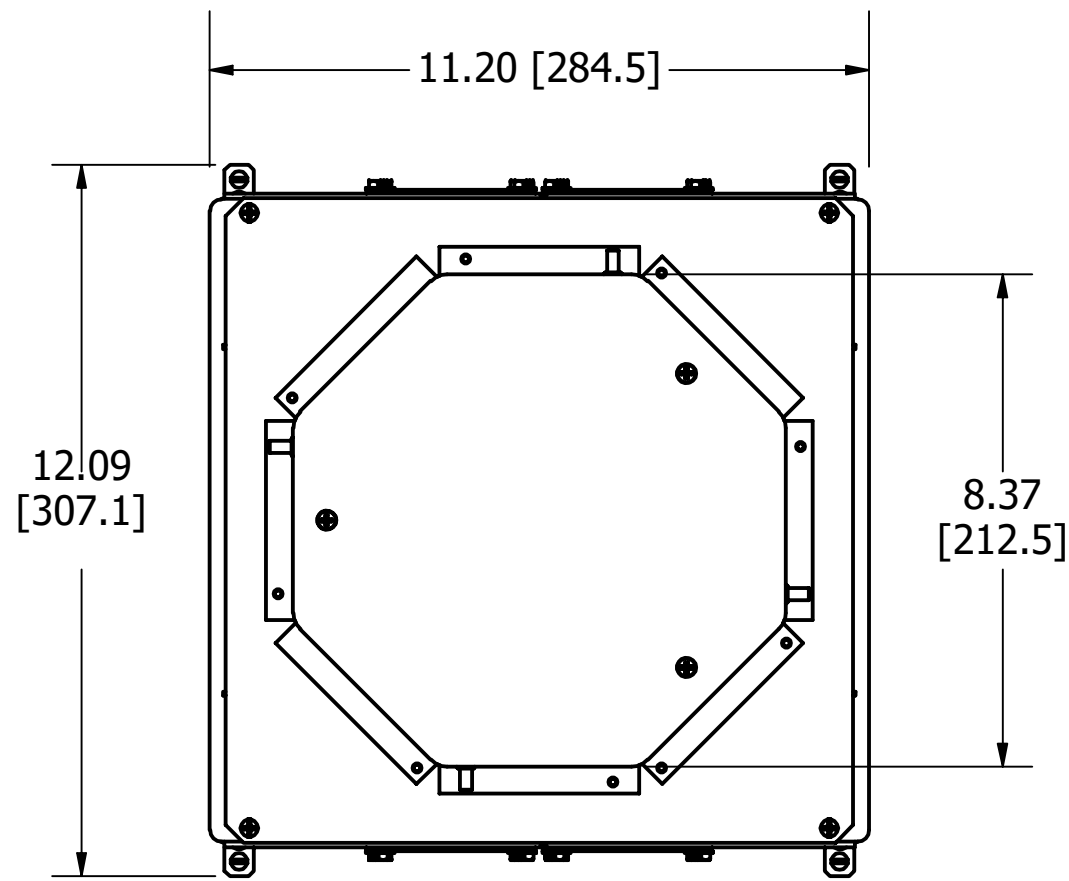

TOP VIEW

NOTES:

1. CFB4G30 SERIES SUPPLIED WITH RECTANGULAR COVER FOR 2 1/2 AND 3 INCH MIN. POUR.
2. CFB4G30R SERIES SUPPLIED WITH ROUND COVER FOR 3 1/4 AND 3 3/4 INCH MIN. POUR.
3. BOX TYPE WHICH INCLUDES STANDARDS, CORROSION-RESISTANT, CAST IRON.
4. FOLLOW MANUFACTURERS DIRECTIONS AND GUIDELINES FOR THE INSTALLATION AND MOUNTING OF THE FLOOR BOX AND ALL OF THE ASSOCIATED COMPONENTS.

THE DESIGN AND DIMENSIONS OF THE PRODUCT SHOWN ON THIS DRAWING ARE SUBJECT TO CHANGE WITHOUT NOTICE

TITLE

4 GANG RECESSED FLOOR BOX

TOLERANCES UNLESS OTHERWISE SPECIFIED

.XX = ± .01  
.XXX = ± .005  
ANGLES = ± 2'

WIRING DEVICE-KELLEMS  
HUBBELL INCORPORATED  
SHELTON, CT

DR. BY	APP. BY
TR. BY	SCALE
CHK. BY	DATE

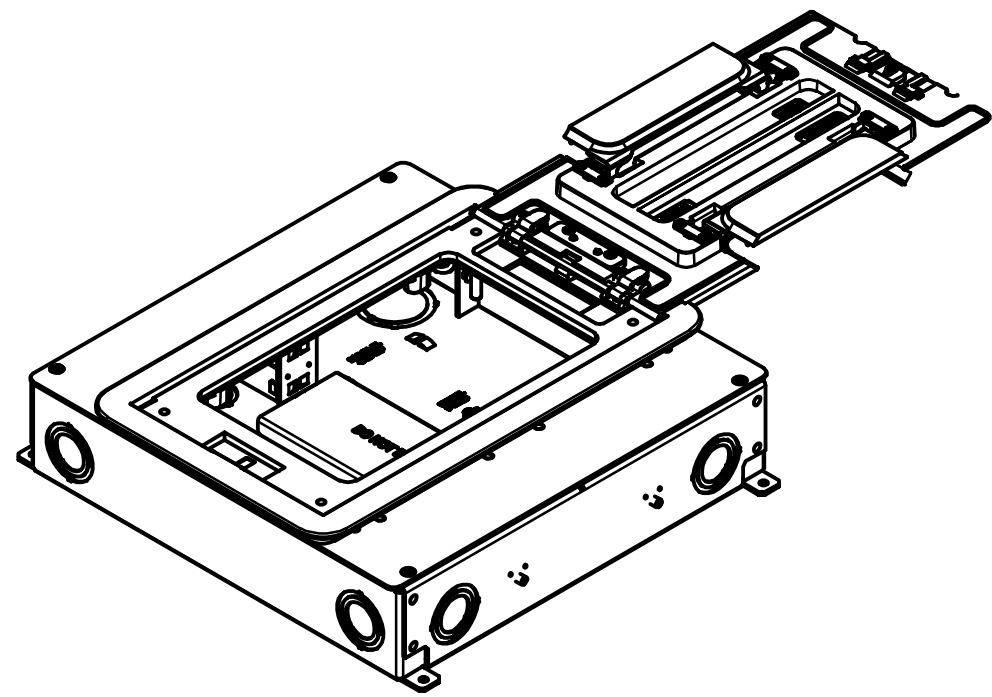

CFB4G25 / CFB4G30  
(RECTANGULAR COVER OPEN)

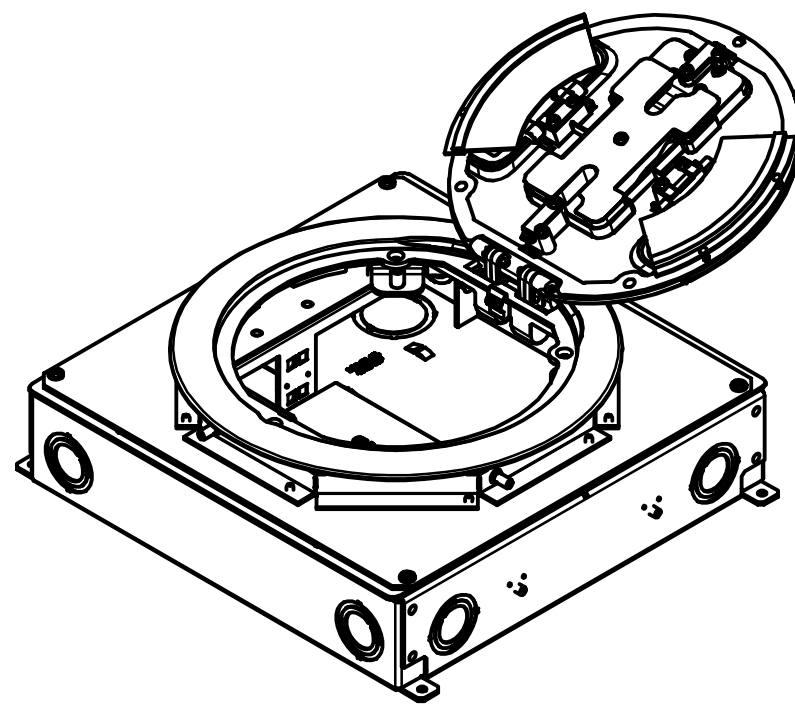

CFB4G25R / CFB4G30R  
(ROUND COVER OPEN)

SYSTEM ONE 4 GANG PLATES AND ACCESSORIES

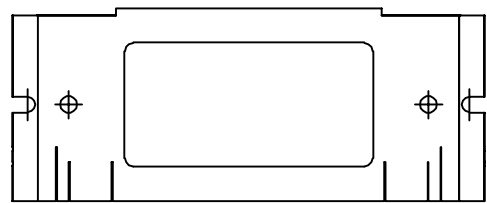

CATALOG NO.	FBMPREC
DESCRIPTION:	STYLELINE DECORATOR PLATE

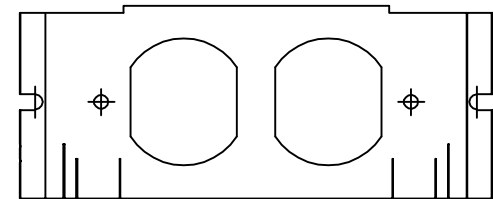

CAT. No.	DESCRIPTION
FBMPDUP	DUPLEX

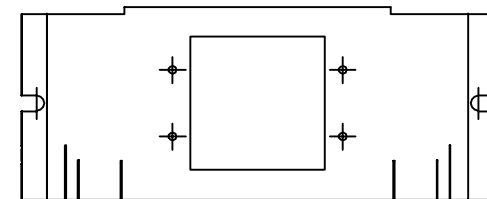

CAT. No.	DESCRIPTION
FBMPMAAP	EXTRON MAAP OR FR IPS

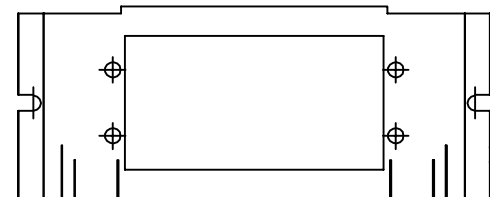

CAT. No.	DESCRIPTION
FBMPAAP	2-UNIT EXTRON AAP

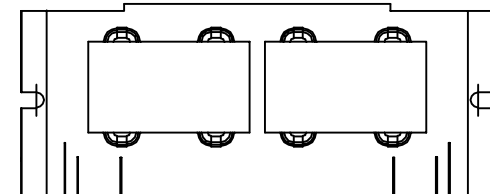

CAT. No.	DESCRIPTION
FBMP2IM	2-UNIT iSTATION®

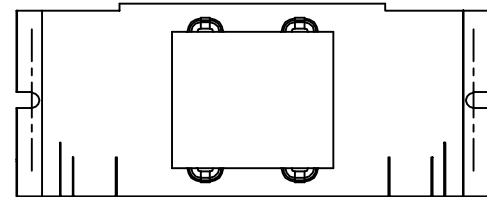

CAT. No.	DESCRIPTION
FBMP15IM	1.5-UNIT iSTATION®

THE DESIGN AND DIMENSIONS OF THE PRODUCT SHOWN ON THIS DRAWING ARE SUBJECT TO CHANGE WITHOUT NOTICE

TITLE  
4 GANG RECESSED FLOOR BOX

TOLERANCES UNLESS OTHERWISE SPECIFIED  
.XX = ± .01  
.XXX = ± .005  
ANGLES = ± 2'

WIRING DEVICE-KELLEMS  
HUBBELL INCORPORATED  
SHELTON, CT

DR. BY	APP. BY
TR. BY	SCALE
CHK. BY	DATE

SYSTEM ONE 4 GANG PLATES AND ACCESSORIES

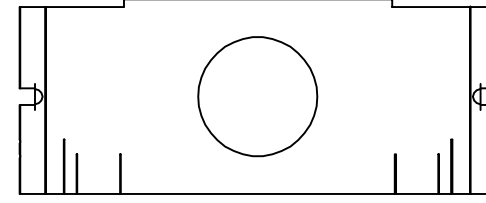
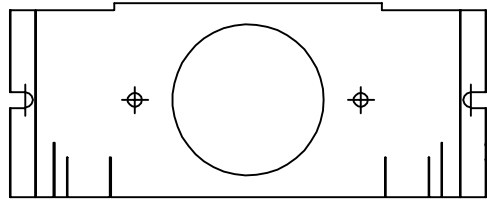

CAT. No.	DESCRIPTION	DIM "A"
FBMP156	TWISTLOCK®	ø1.60 [40.5]
FBMP139	SIMPLEX OR TWISTLOCK®	ø1.41 [35.7]

CAT. No.	DESCRIPTION
FBMPBNK	BLANK PLATE

CAT. No.	DESCRIPTION
FBMPFT	FEED THRU (INCLUDES BUSHING)

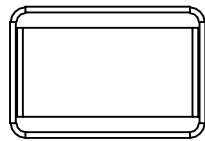
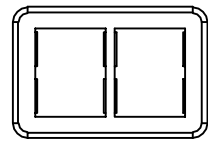

THERMOPLASTIC INSERT SUPPLIED

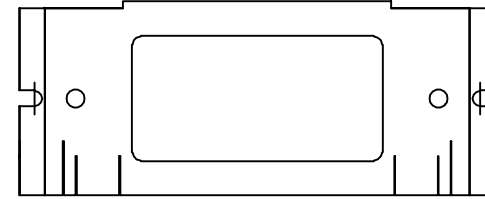
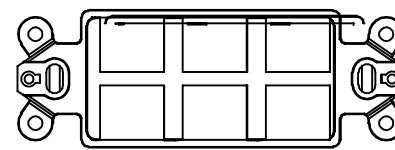
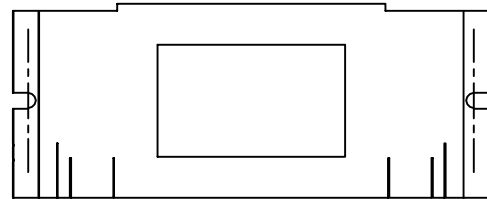

CAT. No.	DESCRIPTION
FBMPTRAC	FOR TWO ORTRONICS TrackJack® OR ONE Series II® DATAKOM INSERT

CAT. No.	DESCRIPTION
FBMP6KS	6-PORT KEYSTONE BEZEL

THE DESIGN AND DIMENSIONS OF THE PRODUCT SHOWN ON THIS DRAWING ARE SUBJECT TO CHANGE WITHOUT NOTICE

TITLE  
4 GANG RECESSED FLOOR BOX

TOLERANCES UNLESS OTHERWISE SPECIFIED	WIRING DEVICE-KELLEMS HUBBELL INCORPORATED SHELTON, CT		
	.XX = ± .01	DR. BY	APP. BY
	.XXX = ± .005	TR. BY	SCALE
	ANGLES = ± 2'	CHK. BY	DATE

- \* THE FLOOR BOXES, COVERS AND SUB-PLATES ARE ALL UL514A & cULus LISTED.
- \* AVAILABLE IN PRE-WIRED PLATES WHICH REDUCES WIRING AND INSTALLATION TIMES FOR 15A AND 20A
- \* MOUNTING HARDWARE INCLUDED.

SYSTEM ONE 4 GANG RECTANGULAR COVER- SURFACE STYLE

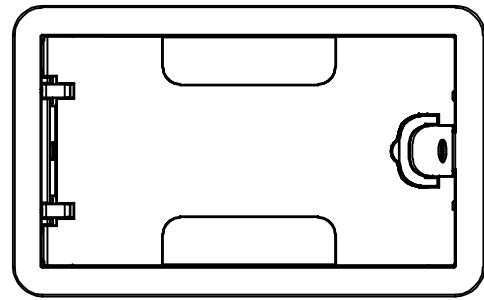

24GCCVRRXX (FLUSH)

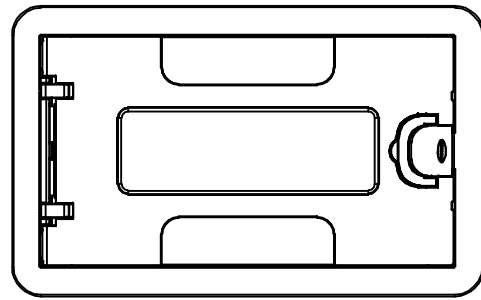

24GCCVRRXC (WITH INSERT)

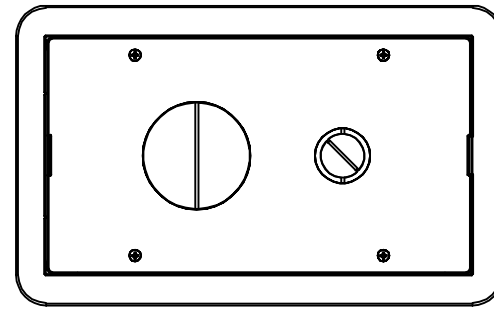

24GCFFCVRXX (FURNITURE FEED)

SYSTEM ONE 4 GANG RECTANGULAR COVER- FLUSH STYLE

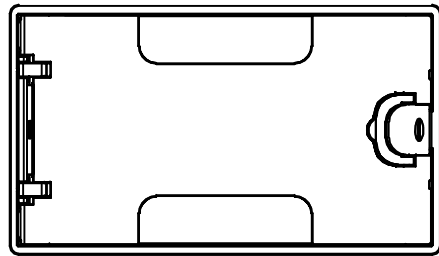

24GTCVRRXX (FLUSH)

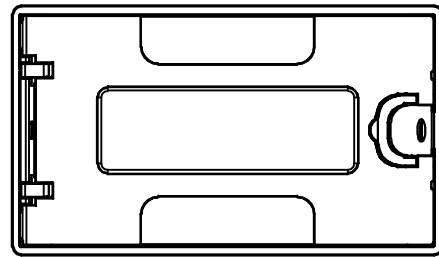

24GTCVRRXC (WITH INSERT)

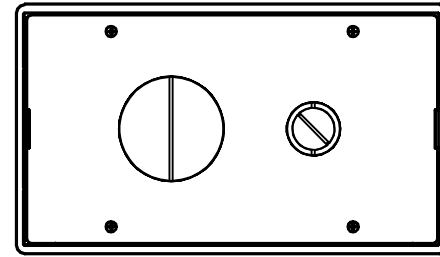

24GTFFCVRXX (FURNITURE FEED)

SYSTEM ONE 4 GANG ROUND COVER

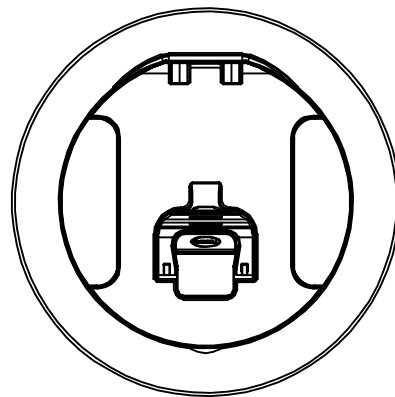

CFBS1R8CVRXX

\* XX INDICATES FLOOR BOX ON THIS PAGE ARE AVAILABLE IN THE FOLLOWING COVER COLOR OPTION AS INDICATED BY THE CATALOG NUMBERS. ALU-ALUMINUM POWDER COAT, BK- BLACK POWDER COAT, BRS- BRASS POWDER COAT, BRZ- BRONZE POWDER COAT, NK- SATIN NICKEL POWDER COAT.

THE DESIGN AND DIMENSIONS OF THE PRODUCT SHOWN ON THIS DRAWING ARE SUBJECT TO CHANGE WITHOUT NOTICE

TITLE  
4 GANG RECESSED FLOOR BOX

TOLERANCES UNLESS OTHERWISE SPECIFIED .XX = ± .01 .XXX = ± .005 ANGLES = ± 2'	WIRING DEVICE-KELLEMS HUBBELL INCORPORATED SHELTON, CT	
	DR. BY	APP. BY
	TR. BY	SCALE
	CHK. BY	DATE