

M-6401 1

LIST OF PARTS

DESCRIPTION	MATERIAL	FINISH
BLADE HOLDER	NYLON	NATURAL
RETAINER	POLYCARBONATE	AMBER
CONTACT BLADES	.060 BRASS	
GR. CONTACT BLADE	.040 BRASS	
BINDING SCREWS	BRASS	*
GR HEX HD BIND'G SCR	BRASS	GREEN
WIRE CLAMPS	.062 STEEL	ZINC PLATE
SPACER	NYLON	YELLOW
OUTER SLEEVE	VINYL	YELLOW
CORD CLAMPS	NYLON	YELLOW

DIMENSION SHEET FOR CAT. NO. SEE TABLE

REPAIRABLE

NON-REPAIRABLE

B

M-6401

1

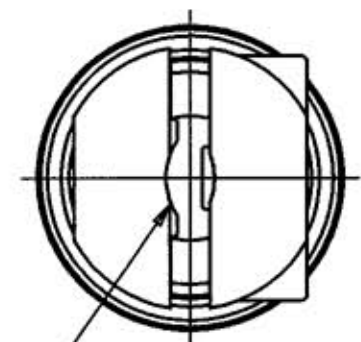
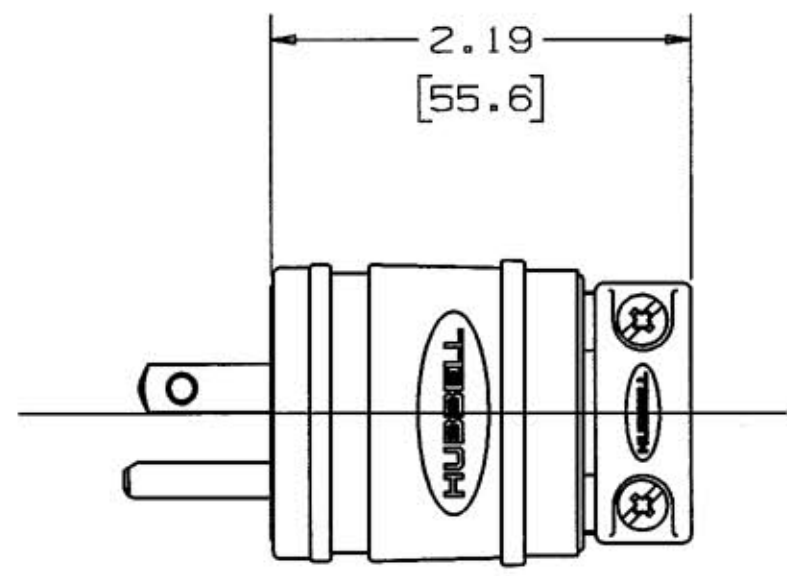
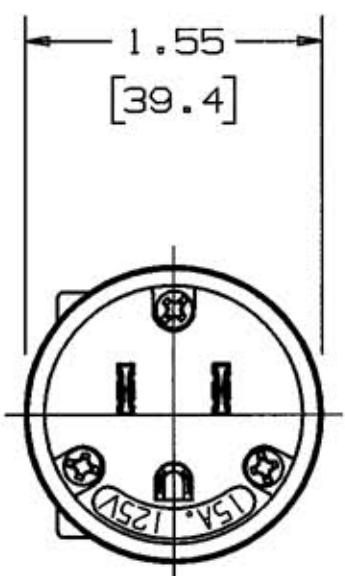

CABLE CLAMP TAKES CABLES FROM .300 TO .655 [ 7.6 ] [ 16.6 ]

\* WHITE FINISH ON NEUTRAL

SUPERSEDES DRAWING DATED 5-4-84

1	REDRAWN WITH CHANGES; ADDED "HBL" TO 1447, 1433, & 2447; DUAL DIMENSIONS WERE FRACTIONAL ONLY; ADDED NOTES 1 & 2; "SEE TABLE" WAS "SEE CHART"; RETAINER MATERIAL "POLYCARBONATE" WAS "LEXAN"; PER DCN #8682. JMN	TCM	12/7/01
SYM	REVISIONS	APP	DATE

THE DESIGN AND DIMENSIONS OF THE PRODUCT SHOWN ON THIS DRAWING ARE SUBJECT TO CHANGE WITHOUT NOTICE

TITLE  
2 POLE 3 WIRE ELASROMERIC PLUGS

TOLERANCES UNLESS OTHERWISE SPECIFIED FRACTIONS ±1/64 DECIMALS ±.005 ANGLES ±2°	WIRING DEVICE-KELLEMS HUBBELL INCORPORATED BRIDGEPORT, CT	
	DR. BY A.Z.	APP. BY J.N.C.
	TR. BY J.M.N.	SCALE 1:1
	CHK'D BY	DATE 6/9/00

CAT. NO.	CONFIGURATION	RATING
HBL1447	NEMA 5-15P NON-LOCKING	15A.125V
HBL1433	NEMA 5-20P NON-LOCKING	20A.125V
HBL2447	NEMA L5-15P LOCKING	15A.125V

NOTES: (UNLESS OTHERWISE SPECIFIED)

- 1) DIMENSION FORMAT IS: INCHES [ mm ]
- 2) DIMENSIONS SHOWN ON THIS DRAWING ARE NOMINAL VALUES FOR GENERAL USE ONLY. ACTUAL PART TOLERANCES MUST BE OBTAINED FROM HUBBELL ENGINEERING.