

M-7819 4

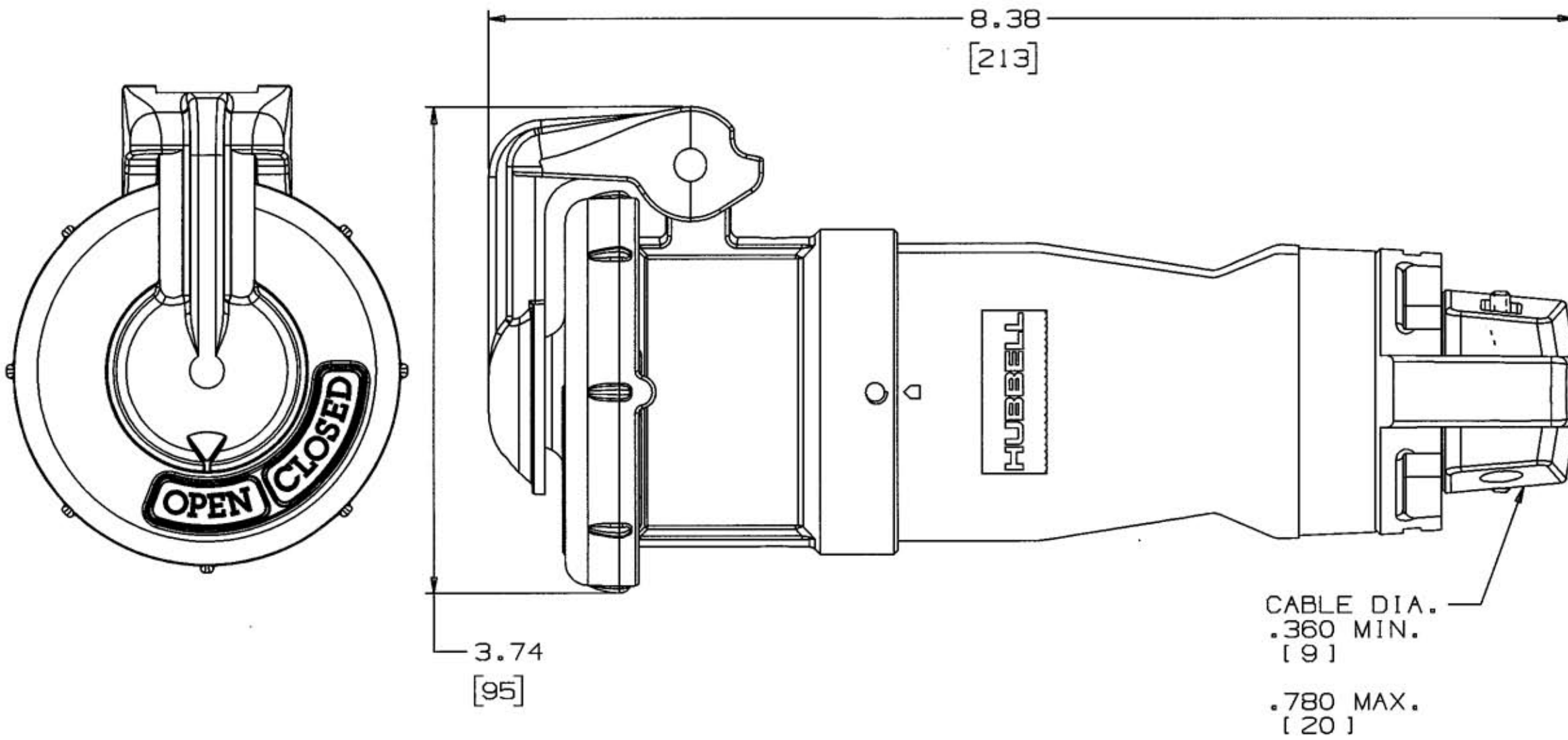

NOTES: (UNLESS OTHERWISE SPECIFIED)
 1) DIMENSION FORMAT IS: INCHES
 [mm]

| AMPS | POLES AND WIRES | MAX VOLTAGE AC/DC | STYLE | CONNECTOR CATALOG NUMBER |
|------|-----------------|-------------------|-------|--------------------------|
| 30 | 2P3W | 600/250 | S1 | HBL330CS1W |
| 30 | 3P4W | 600/250 | S1 | HBL430CS1W |
| 30 | 4P5W | 600/250 | S1 | HBL530CS1W |
| 30 | 2P3W | 600/250 | S2 | HBL330CS2W |
| 30 | 3P4W | 600/250 | S2 | HBL430CS2W |

| DESCRIPTION | MATERIAL | FINISH |
|-----------------|-------------------------|---------------|
| BOX TERMINAL | STEEL | NICKEL PLATE |
| GROUND STANDOFF | BRASS | |
| GROUND BRACKET | COPPER ALLOY | NICKEL PLATE |
| HINGE BUSHING | ALUMINUM | |
| SPRING GUIDE | STAIN STEEL | |
| LID SPRING | STAIN STEEL | |
| LID | ALUMINUM | GRAY EPOXY |
| LID LIFTER | ALUMINUM | GRAY EPOXY |
| O-RING | RUBBER | |
| LID GASKET | RUBBER | |
| CLAMP NUT | BRASS | NICKEL PLATE |
| GLAND | RUBBER | |
| SPRING WASHER | STAIN STEEL | |
| WAVE SPRING | STAIN STEEL | |
| RIVET | ALUMINUM | |
| CONNECTOR | ALUMINUM | GRAY EPOXY |
| SET SCREW | STAIN STEEL | |
| SCREWS | STAIN STEEL | |
| INTERIOR | THERMOSET POLYESTER | |
| PLUG BODY | THERMOPLASTIC POLYESTER | |
| PIN SPRING | COPPER ALLOY | SILVER COATED |
| PINS | BRASS | |

| REPAIRABLE <input checked="" type="checkbox"/> NON-REPAIRABLE <input type="checkbox"/> | | | |
|--|---|-----|----------|
| 4 | ADDED TABLE, "SEE TABLE", AND NOTE 1; DRAWING TITLE WAS "30A PIN & SLEEVE RECEPTACLE ASSEMBLY STYLES 1 & 2"; REMOVED "mm" FROM DIMENSIONS; PER DCN #8695. JMN | TCM | 1/21/02 |
| 3 | DCN 5807-8 2/9/99 UPDATED LIST OF PARTS | | |
| 2 | RELEASED PER DCN-5581 RDK | RDK | 10/10/97 |
| 1 | RELEASED PER DCN-5357 FMB | RDK | 10/01/97 |
| SYM | REVISIONS | APP | DATE |

THE DESIGN AND DIMENSIONS OF THE PRODUCT SHOWN ON THIS DRAWING ARE SUBJECT TO CHANGE WITHOUT NOTICE

TITLE
 30A INSULGRIP PIN & SLEEVE CONNECTOR STYLES 1 & 2

| | | |
|---------------------------------------|---|---------------|
| TOLERANCES UNLESS OTHERWISE SPECIFIED | WIRING DEVICE-KELLEMS HUBBELL INCORPORATED BRIDGEPORT, CT | |
| FRACTIONS ±1/64 | DR. BY FMB | APP. BY RDK |
| 3DECIMALS ±.005 | TR. BY | SCALE 1:1 |
| ANGLES ±2° | CHK'D BY RDK | DATE 10/01/97 |
| 2DECIMALS ±.01 | | |

DIMENSION SHEET FOR CAT. NO. SEE TABLE

REPAIRABLE

NON-REPAIRABLE

B

M-7819

4