

M-7818 4

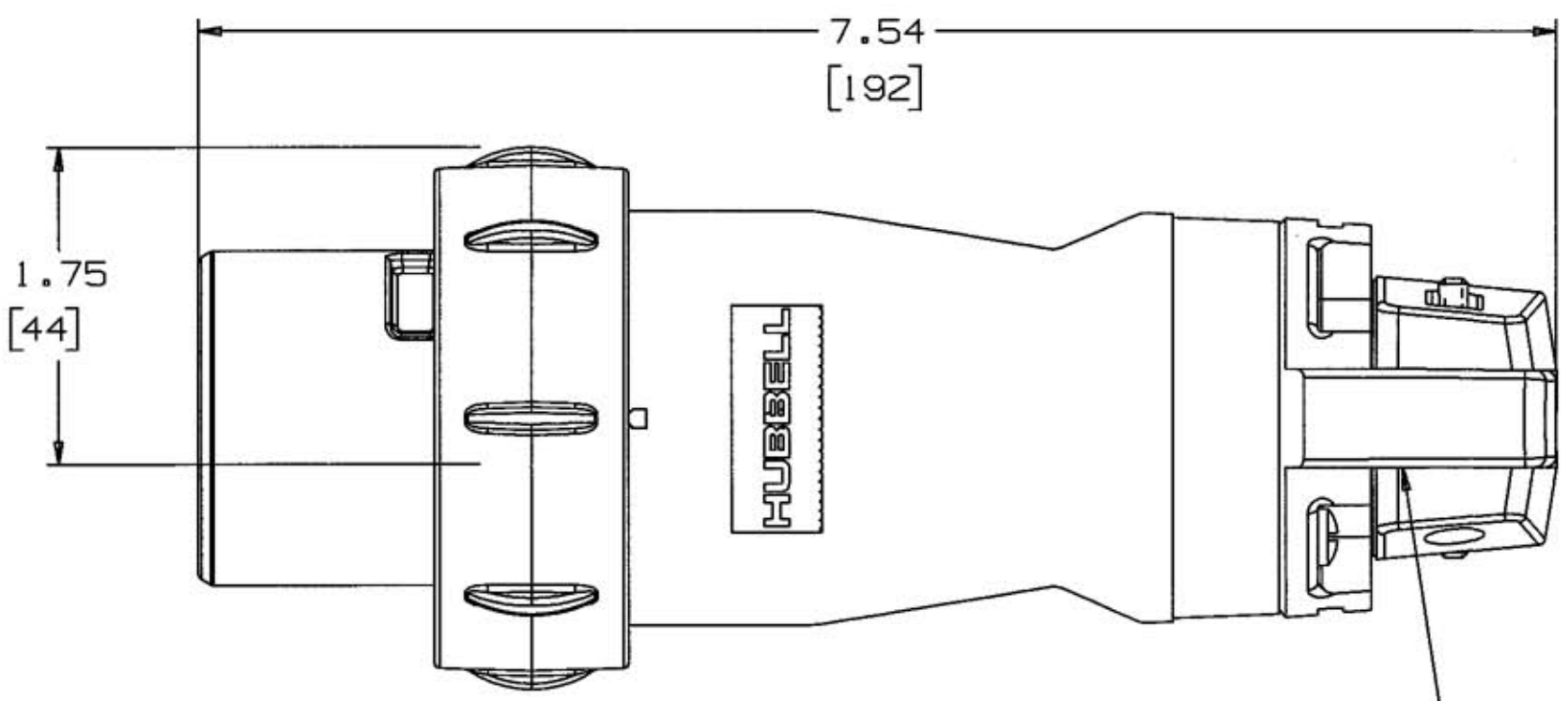
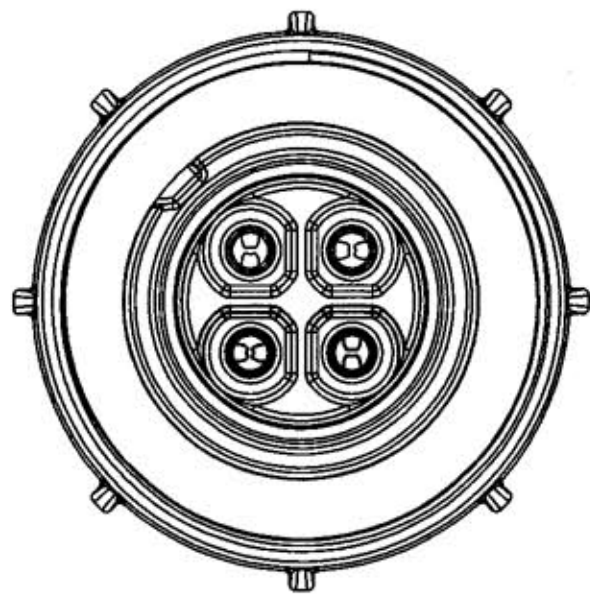

CABLE DIA.
 .360 MIN.
 [9]
 .780 MAX.
 [20]

NOTES: (UNLESS OTHERWISE SPECIFIED)

1) DIMENSION FORMAT IS: INCHES
 [mm]

AMPS	POLES AND WIRES	MAX VOLTAGE AC/DC	STYLE	CONNECTOR CATALOG NUMBER
30	2P3W	600/250	S1	HBL330PS1W
30	3P4W	600/250	S1	HBL430PS1W
30	4P5W	600/250	S1	HBL530PS1W
30	2P3W	600/250	S2	HBL330PS2W
30	3P4W	600/250	S2	HBL430PS2W

LIST OF PARTS

DESCRIPTION	MATERIAL	FINISH
BOX TERMINAL	STEEL	NICKEL PLATE
GROUND STANDOFF	BRASS	
GROUND BRACKET	COPPER ALLOY	NICKEL PLATE
O-RING	RUBBER	
SLEEVES	BRASS	
CLAMP NUT	BRASS	NICKEL PLATE
CAP GLAND	PET	
CLAMP	PET	
GLAND	RUBBER	
LOCK COLLAR	ALUMINUM	GRAY EPOXY
SHROUD	ALUMINUM	
SET SCREW	STAIN STEEL	
SCREWS	STAIN STEEL	
INTERIOR	THERMOSET POLYESTER	
PLUG BODY	THERMOPLASTIC POLYESTER	

SYM	REVISIONS	APP	DATE
4	ADDED TABLE, "SEE TABLE" AND NOTE 1; DRAWING TITLE WAS "30A PIN & SLEEVE PLUG ASSEMBLY STYLES 1 & 2"; REMOVED "mm" FROM DIMENSIONS; 7.54 DIM. WAS 7.53; PER DCN #8695. JMN	TCM	1/21/02
3	DCN 5807-8 2/9/99 UPDATED LIST OF PARTS		
2	DCN 5581 CHANGED MAT. FROM THERMOSET TO THERMOPLASTIC	RDK	10/10/97
1	RELEASED PER DCN-5357 FMB	RDK	10/01/97

THE DESIGN AND DIMENSIONS OF THE PRODUCT SHOWN ON THIS DRAWING ARE SUBJECT TO CHANGE WITHOUT NOTICE

TITLE
 30A INSULGRIP PIN & SLEEVE PLUG
 STYLES 1 & 2

TOLERANCES UNLESS OTHERWISE SPECIFIED	WIRING DEVICE-KELLEMS HUBBELL INCORPORATED BRIDGEPORT, CT	
FRACTIONS ±1/64	DR. BY FMB	APP. BY RDK
3DECIMALS ±.005	TR. BY	SCALE 1:1
ANGLES ±2°	CHK'D BY RDK	DATE 10/01/97
2DECIMALS ±.01		

DIMENSION SHEET FOR CAT. NO. SEE TABLE
 REPAIRABLE NON-REPAIRABLE
B
M-7818
 4