

M-7932 3

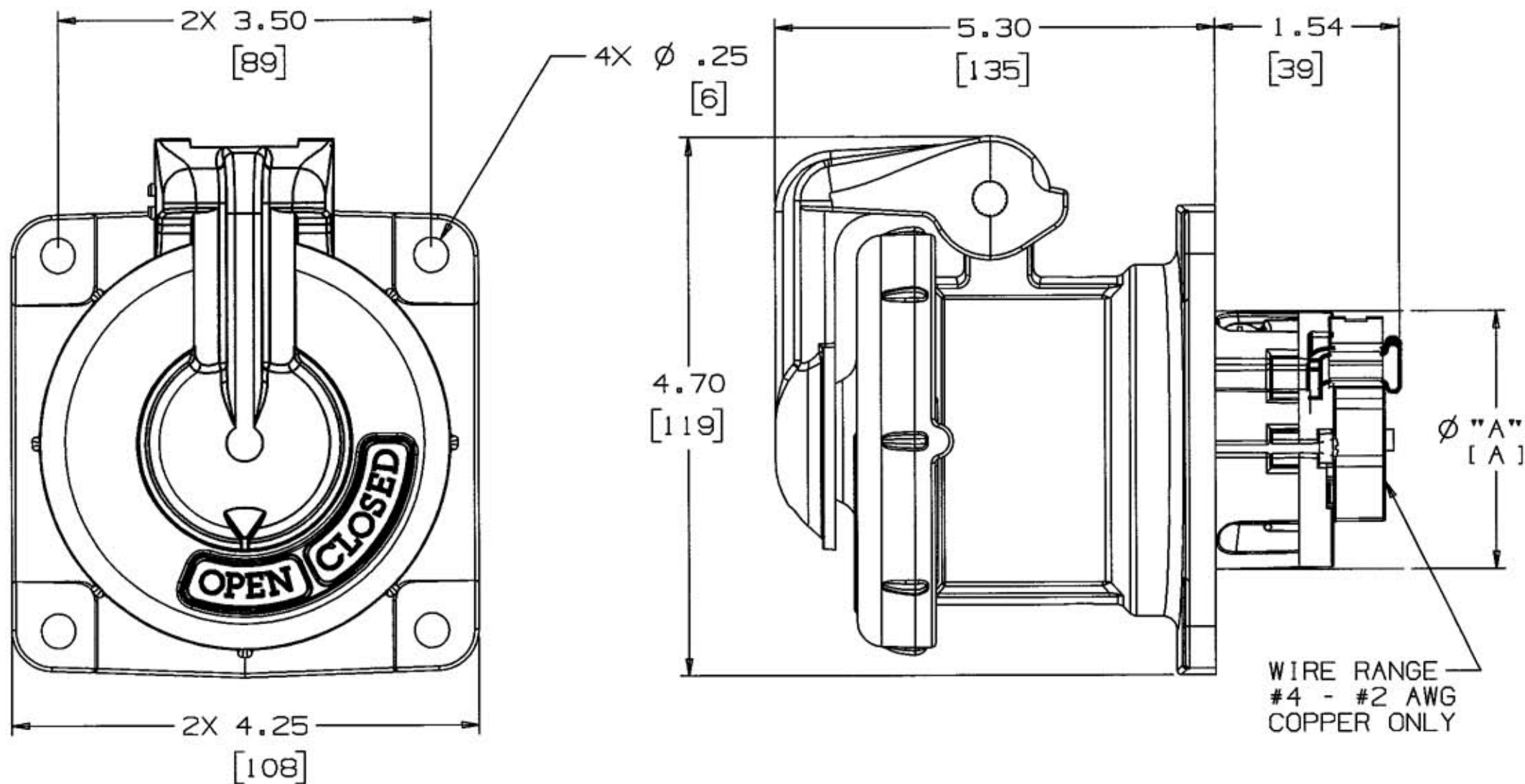

NOTES: (UNLESS OTHERWISE SPECIFIED)

1) DIMENSION FORMAT IS: INCHES
[mm]

AMPS	POLES AND WIRES	MAX VOLTAGE AC/DC	STYLE	Ø "A" [A]	CONNECTOR CATALOG NUMBER
100	2P3W	600/250	S1	2.485 [63.12]	HBL3100RS1W
100	3P4W	600/250	S1	2.72 [69.1]	HBL4100RS1W
100	2P3W	600/250	S2	2.485 [63.12]	HBL3100RS2W
100	4P5W	600/250	S1	2.72 [69.1]	HBL5100RS1W
100	3P4W	600/250	S2	2.72 [69.1]	HBL4100RS2W

LIST OF PARTS

DESCRIPTION	MATERIAL	FINISH
BOX TERMINAL	STEEL	NICKEL PLATE
GROUND STANDOFF	BRASS	
GROUND BRACKET	COPPER ALLOY	NICKEL PLATE
HINGE BUSHING	ALUMINUM	
SPRING GUIDE	STAIN STEEL	
LID SPRING	STAIN STEEL	
LID	ALUMINUM	GRAY EPOXY
LID LIFTER	ALUMINUM	GRAY EPOXY
O-RING	RUBBER	
LID GASKET	RUBBER	
SPRING WASHER	STAIN STEEL	
SCREW - LID	STAIN STEEL	
WAVE SPRING	STAIN STEEL	
RIVET	ALUMINUM	
RECEPTACLE	ALUMINUM	GRAY EPOXY
SCREWS	STAIN STEEL	
PIN SPRING	COPPER ALLOY	SILVER COATED
INTERIOR	THERMOSET POLYESTER	
PINS	BRASS	

SYM	REVISIONS	APP	DATE
3	ADDED TABLE, "SEE TABLE", NOTE 1, AND "2X" TO 4.25 [108] & 3.50 [89]; DRAWING TITLE WAS "100A PIN & SLEEVE RECEPTACLE ASSEMBLY STYLES 1 & 2"; REMOVED "mm" FROM DIMENSIONS; ADDED "COPPER ONLY" TO "WIRE RANGE #4 - #2 AWG"; PER DCN #8695. JMN	TCM	1/23/02
2	DCN 5807-8 2/10/99 UPDATED LIST OF PARTS		
1	RELEASED PER DCN-5807 3/26/98 DJH	RDK	4/18/98

THE DESIGN AND DIMENSIONS OF THE PRODUCT SHOWN ON THIS DRAWING ARE SUBJECT TO CHANGE WITHOUT NOTICE

TITLE
100A INSULGRIP PIN & SLEEVE RECEPTACLE
STYLE 1 & 2

TOLERANCES UNLESS OTHERWISE SPECIFIED
FRACTIONS ± 1/64
3 DECIMALS ± .005
ANGLES ± 2°
2 DECIMALS ± .01

WIRING DEVICE-KELLEMS
HUBBELL INCORPORATED
BRIDGEPORT, CT
DR. BY DJH APP. BY RDK
TR. BY SCALE NONE
CHK'D BY RDK DATE 3/26/98