

M-8263 2

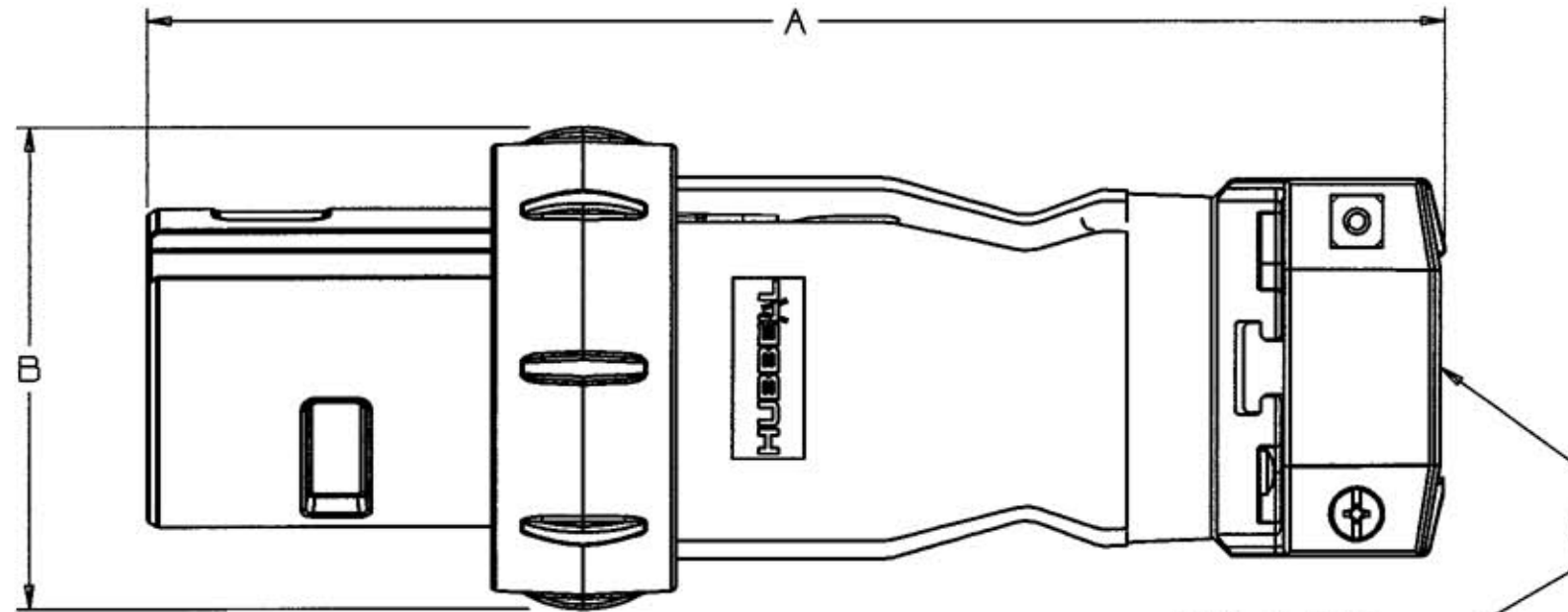
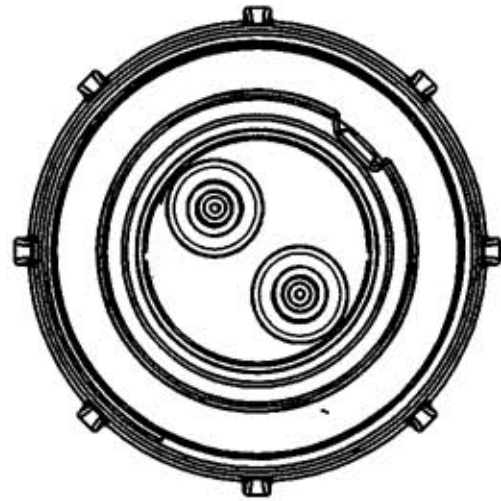

CABLE DIA.  
.500 MIN.  
[ 12 ]  
1.45 MAX.  
[ 36 ]

NOTES: (UNLESS OTHERWISE SPECIFIED)  
1) DIMENSION FORMAT IS: INCHES  
[ mm ]

TABLE

AMPS	MAX VOLTAGE AC/DC	CONNECTOR CATALOG NUMBER	PLUG			DIM "A"		DIM "B" Ø	
			STYLE	POLE	WIRE	INS.	mm	INS.	mm
60	600/250	HBL360PS1WR	S1	2P	3W	9.4	239	3.4	86
60	600/250	HBL460PS1WR	S1	3P	4W				
60	600/250	HBL360PS2WR	S2	2P	3W	9.6	244	3.7	94
60	600/250	HBL560PS1WR	S1	4P	5W				
60	600/250	HBL460PS2WR	S2	3P	4W				

LIST OF PARTS

DESCRIPTION	MATERIAL	FINISH
BOX TERMINAL	STEEL	NICKEL PLATE
GROUND STANDOFF	BRASS	
GROUND BRACKET	COPPER ALLOY	NICKEL PLATE
O-RING	RUBBER	
PINS	BRASS	
CLAMP NUT	BRASS	NICKEL PLATE
CAP GLAND	PET	
CLAMP	PET	
GLAND	RUBBER	
LOCK COLLAR	ALUMINUM	GRAY EPOXY
SHROUD	ALUMINUM	
SET SCREW	STAIN STEEL	
SCREWS	STAIN STEEL	
INTERIOR	THERMOSET POLYESTER	
PLUG BODY	THERMOPLASTIC POLYESTER	

2	ADDED COLUMNS "AMPS", "MAX VOLTAGE AC/DC", & "CONNECTOR CATALOG NUMBER" TO TABLE, "SEE TABLE", AND NOTE 1; DRAWING TITLE WAS "60A PIN & SLEEVE REVERSE PLUG ASSEMBLY STYLES 1 & 2"; REMOVED "MM" FROM DIMENSIONS; PER DCN #8695. JMN	TCM	1/24/02
---	--	-----	---------

1	NEW RELEASE PER DCN 7013 RTK	RDK	8/23/99
SYM	REVISIONS	APP	DATE

THE DESIGN AND DIMENSIONS OF THE PRODUCT SHOWN ON THIS DRAWING ARE SUBJECT TO CHANGE WITHOUT NOTICE

TITLE 60A PIN & SLEEVE REVERSE SERVICE PLUG STYLE 1 & 2

TOLERANCES UNLESS OTHERWISE SPECIFIED	WIRING DEVICE-KELLEMS HUBBELL INCORPORATED BRIDGEPORT, CT	
FRACTIONS ± 1/64	DR. BY RTK	APP. BY RDK
3DECIMALS ± .005	TR. BY	SCALE N/A
ANGLES ± 2°	CHK'D BY RDK	DATE 8/23/99
2DECIMALS ± .01		

DIMENSION SHEET FOR CAT. NO. SEE TABLE

REPAIRABLE

NON-REPAIRABLE

B

M-8263

2