

M-13838

1

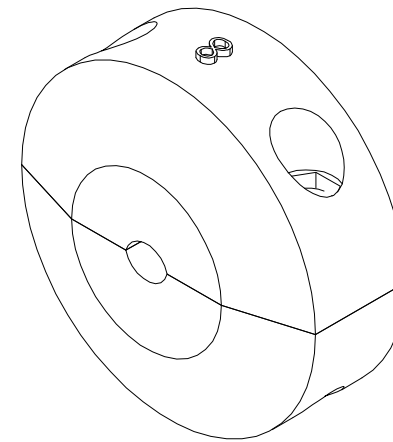
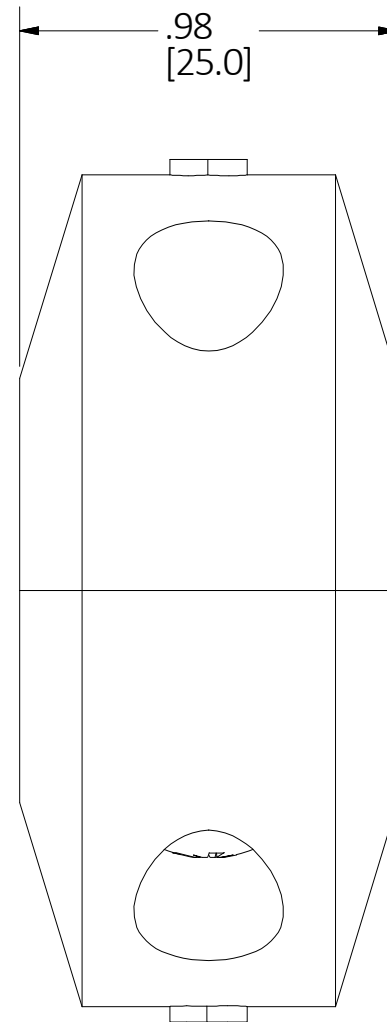
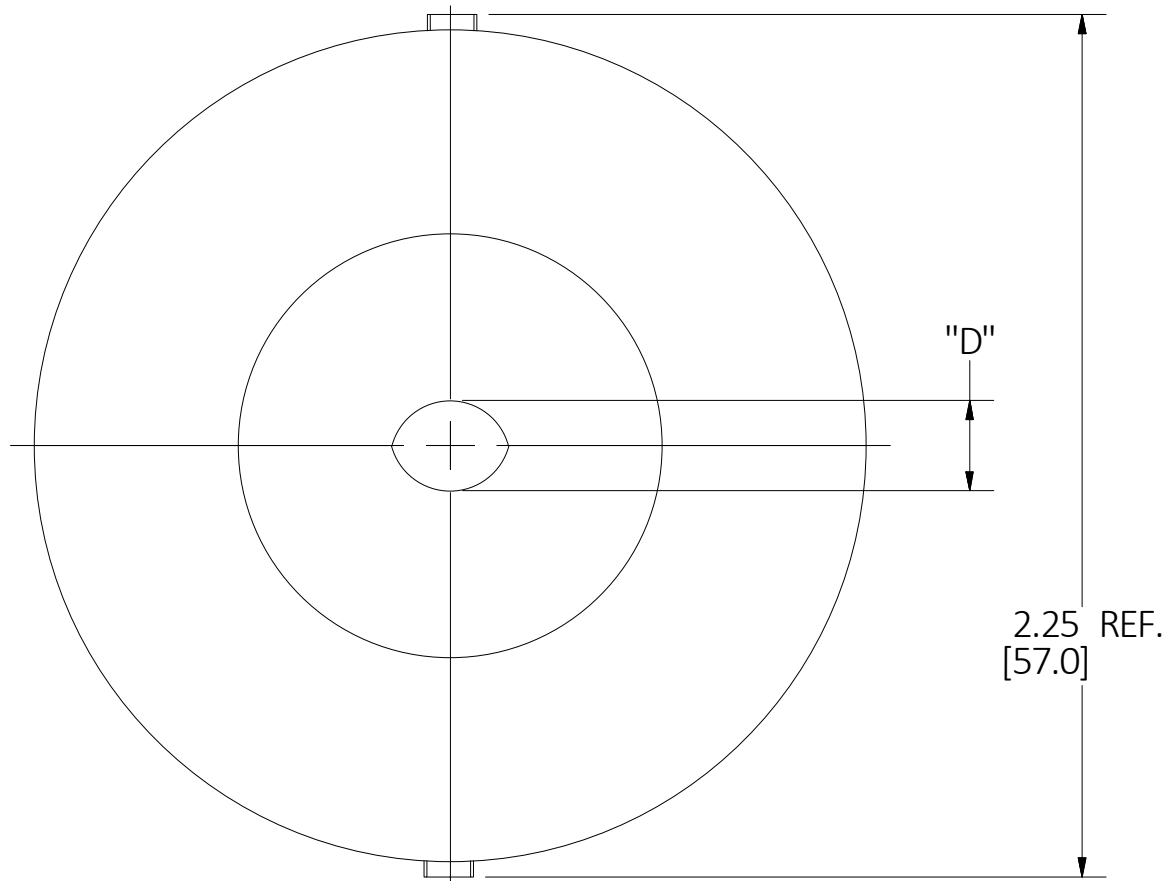

ISOMETRIC VIEW  
SCALE 1 : 1

LIST OF PARTS

DESCRIPTION	MATERIAL	FINISH
HALF BALL STOP	ELASTOMER	COLOR BLACK
SCREW	STEEL	ZINC PLATED
HEX NUT	STEEL	ZINC PLATE

DIMENSION SHEET FOR CAT. NO. SEE TABLE

1	NEW RELEASE PER DCN #24214. D.LI		8/6/18
REV	DESCRIPTION	APP	DATE

THE DESIGN AND DIMENSIONS OF THE PRODUCT SHOWN ON THIS DRAWING ARE SUBJECT TO CHANGE WITHOUT NOTICE. DIMENSIONS ARE IN INCHES [mm].

TITLE  
**BALL STOP, FOR CORD REEL**



WIRING DEVICE-KELLEMS  
HUBBELL INCORPORATED  
SHELTON, CT

TOLERANCES UNLESS OTHERWISE SPECIFIED .XX = ± .01 .XXX = ± .005 ANGLE TOL. ±2'	DR. BY VD CHK. BY MA	SCALE 2 : 1 DATE 29-01-2018
---	-------------------------	--------------------------------

NOTE:  
1. DIMENSIONS ARE IN INCHES [mm].

HBLI10BS	BALL STOP SJ 10/4, SW 12/4 - 10/4	.65 [16.5]	SJO 10/4; SOW 12/4, 10/3, 10/4
HBLI12BS	BALL STOP SJ 12/3 - 12/4, SW 16/4	.39 [10.0]	SJO 12/3, 12/4; SOW 16/4
HBLI14BS	BALL STOP, SJ 10/3, SW 14/3 - 12/3	.51 [13.0]	SJO 10/3; SOW 14/3, 14/4, 12/3
HBLI16BS	BALL STOP, SJ 16/3 -14/4, SW 16/3	.32 [8.0]	SJO 16/3, 16/4, 14/3, 14/4; SOW 16/3
CATALOG	DESCRIPTION	"D"	SUITABLE FOR CORD SIZE