

M-13839

4

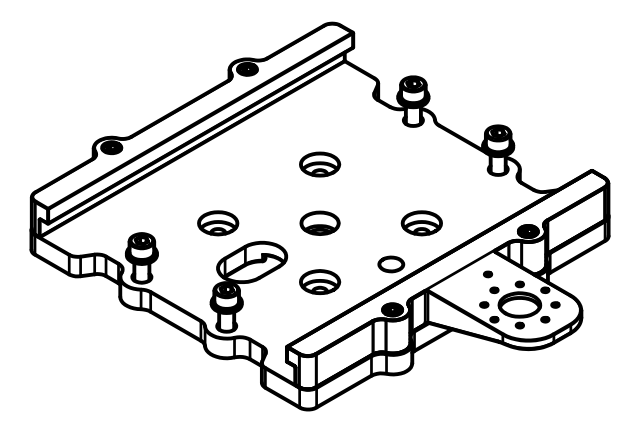
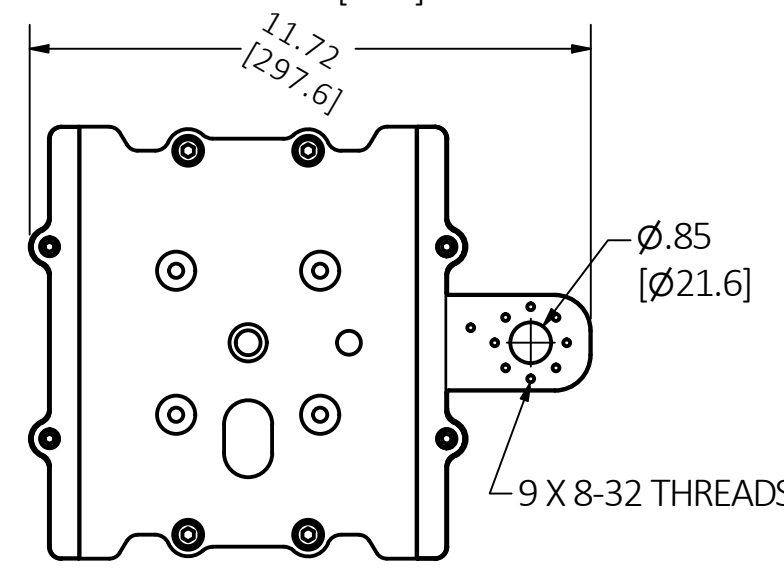
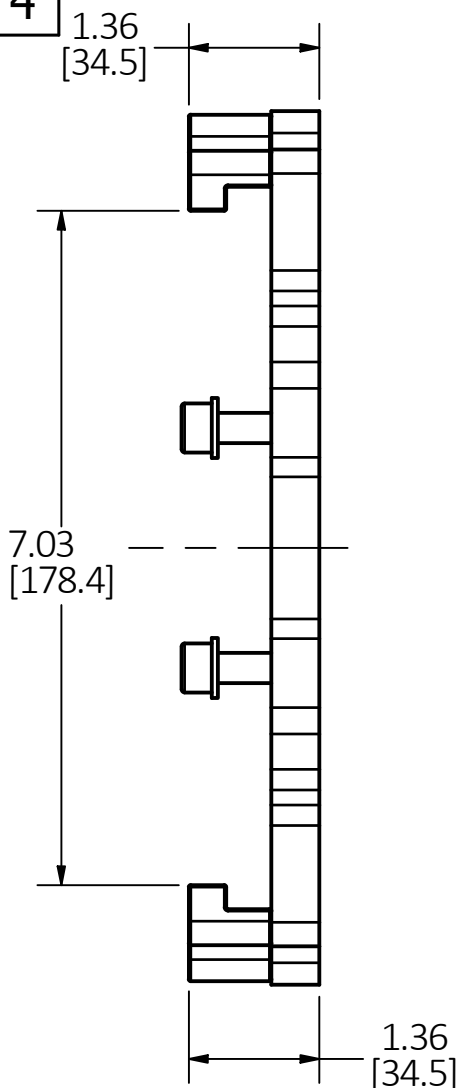
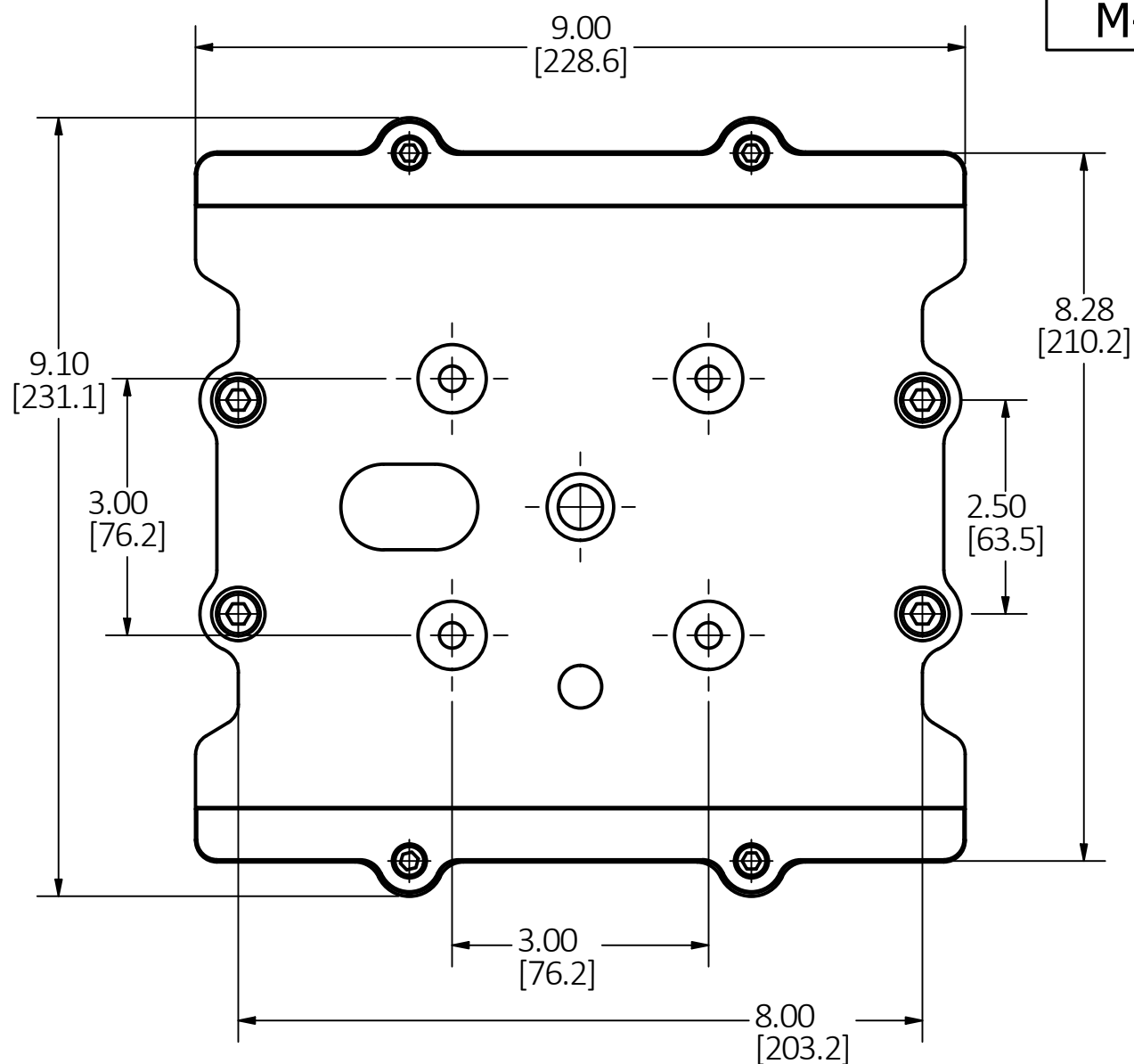

HBLIMBJ (1/4 SCALE)

NOTE:
 1. APPROX. WEIGHT 2.5 LBS.
 2. DIMENSIONS ARE IN INCHES [MM]

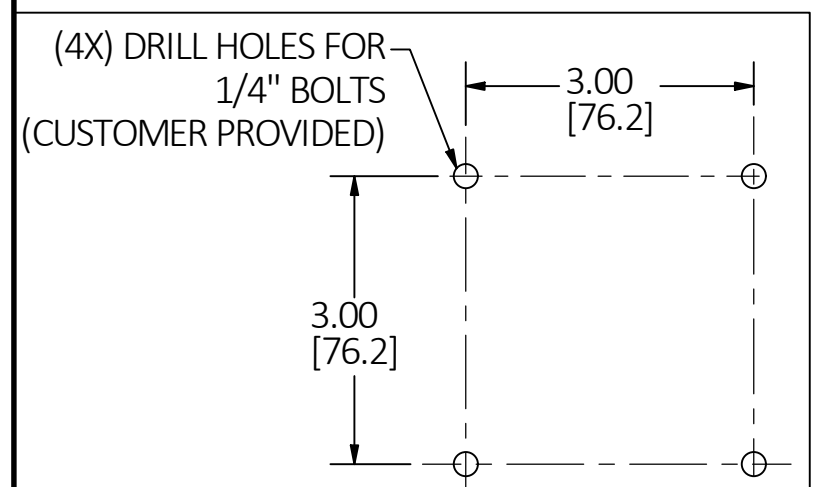

DRILL FOR MOUNTING
 SCALE 1 / 2

CAGE CODE 74545

CAT NO	DESCRIPTION
HBLIMB	REEL, MOUNTING BRACKET
HBLIMBJ	REEL, MOUNTING BRACKET W/ HANDYBOX MOUNT

LIST OF PARTS

DESCRIPTION	MATERIAL	FINISH
RAIL	ALUMINIUM ALLOY	BLACK POWDER COAT
MOUNTING PLATE	ALUMINIUM ALLOY	BLACK POWDER COAT
HEX SCREW	STEEL	ZINC PLATE
NUT	STAINLESS STEEL	
WASHER	STEEL	ZINC PLATE

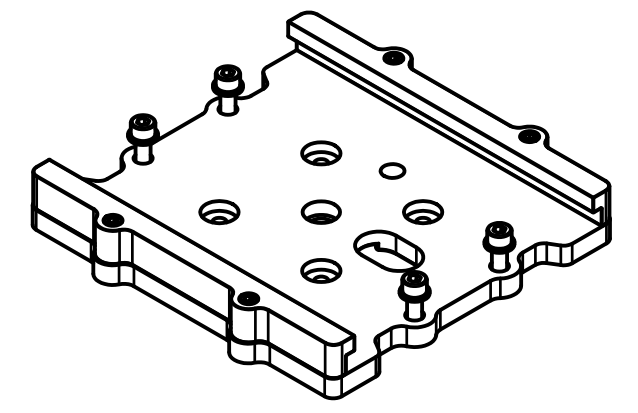

REV	DESCRIPTION	APP	DATE
4	ADDED HBLIMBJ PER DNC#200107120127 EMD		11/19/19
3	ADDED ISO VIEW PER DCN #190321101330. D.LI		4/18/2019
2	ADDED REEL SECURING HARDEARE DCN #24347. D.LI		1/3/2019
1	NEW RELEASE PER DCN #24214. D.LI		8/6/2018

THE DESIGN AND DIMENSIONS OF THE PRODUCT SHOWN ON THIS DRAWING ARE SUBJECT TO CHANGE WITHOUT NOTICE. DIMENSIONS ARE IN INCHES [mm].

TITLE
 MOUNTING BRACKET, FOR CORD REEL



WIRING DEVICE-KELLEMS
 HUBBELL INCORPORATED
 SHELTON, CT

TOLERANCES UNLESS OTHERWISE SPECIFIED .XX = ±.01 .XXX = ±.005 ANGLE TOL. ±2'	DR. BY VD	SCALE 1:2
	CHK. BY MA	DATE 02/01/2018

DIMENSION SHEET FOR CAT. NO. SEE TABLE

B

M-13839

4