

M-13840

3

NOTES:
1. DIMENSIONS ARE IN INCHES [mm]
EXCEPT CORD LENGTH IN FEET.

CATALOG	DESCRIPTION	RATING	CORD LENGTH	CORD COLOR	CORD TYPE	REEL SIZE	REEL COLOR	APPROX. WEIGHT
HBLI45163	IND REEL, UL TYPE 1, 45' SJO, 16/3, 10A MAX. 250V	10A 250V	45 FT.	BLACK	16/3, SJO	3"	WHITE	22.9 LB [10.4KG]
HBLI35163	IND REEL, UL TYPE 1, 35' SJO, 16/3, 10A MAX. 250V	10A 250V	35 FT.	BLACK	16/3, SJO	3"	WHITE	22.0 LB [10.0KG]
HBLI25163	IND REEL, UL TYPE 1, 25' SJO, 16/3, 10A MAX. 250V	10A 250V	25 FT.	BLACK	16/3, SJO	3"	WHITE	21.2 LB [9.6 KG]
HBLI45164	IND REEL, UL TYPE 1, 45' SJO, 16/4, 10A MAX. 250V	10A 250V	45 FT.	BLACK	16/4, SJO	3"	WHITE	23.6 LB [10.7 KG]
HBLI35164	IND REEL, UL TYPE 1, 35' SJO, 16/4, 10A MAX. 250V	10A 250V	35 FT.	BLACK	16/4, SJO	3"	WHITE	22.7 LB [10.3 KG]
HBLI25164	IND REEL, UL TYPE 1, 25' SJO, 16/4, 10A MAX. 250V	10A 250V	25 FT.	BLACK	16/4, SJO	3"	WHITE	21.8 LB [9.9 KG]
HBLI45143	IND REEL, UL TYPE 1, 45' SJO, 14/3, 15A MAX. 250V	15A 250V	45 FT.	BLACK	14/3, SJO	3"	WHITE	24.0 LB [10.9 KG]
HBLI35143	IND REEL, UL TYPE 1, 35' SJO, 14/3, 15A MAX. 250V	15A 250V	35 FT.	BLACK	14/3, SJO	3"	WHITE	22.9 LB [10.4 KG]
HBLI25143	IND REEL, UL TYPE 1, 25' SJO, 14/3, 15A MAX. 250V	15A 250V	25 FT.	BLACK	14/3, SJO	3"	WHITE	21.8 LB [9.9 KG]
HBLI45144	IND REEL, UL TYPE 1, 45' SJO, 14/4, 15A MAX. 250V	15A 250V	45 FT.	BLACK	14/4, SJO	3"	WHITE	25.4 LB [11.5 KG]
HBLI35144	IND REEL, UL TYPE 1, 35' SJO, 14/4, 15A MAX. 250V	15A 250V	35 FT.	BLACK	14/4, SJO	3"	WHITE	24.0 LB [10.9 KG]
HBLI25144	IND REEL, UL TYPE 1, 25' SJO, 14/4, 15A MAX. 250V	15A 250V	25 FT.	BLACK	14/4, SJO	3"	WHITE	22.7 LB [10.3 KG]
HBLI45123	IND REEL, UL TYPE 1, 45' SJO, 12/3, 20A MAX. 250V	20A 250V	45 FT.	BLACK	12/3, SJO	3"	WHITE	26.5 LB [12.0 KG]
HBLI35123	IND REEL, UL TYPE 1, 35' SJO, 12/3, 20A MAX. 250V	20A 250V	35 FT.	BLACK	12/3, SJO	3"	WHITE	24.9 LB [11.3 KG]
HBLI25123	IND REEL, UL TYPE 1, 25' SJO, 12/3, 20A MAX. 250V	20A 250V	25 FT.	BLACK	12/3, SJO	3"	WHITE	23.4 LB [10.6 KG]
HBLI45124	IND REEL, UL TYPE 1, 45' SJO, 12/4, 20A MAX. 250V	20A 250V	45 FT.	BLACK	12/4, SJO	4.75"	WHITE	29.8 LB [13.5 KG]
HBLI35124	IND REEL, UL TYPE 1, 35' SJO, 12/4, 20A MAX. 250V	20A 250V	35 FT.	BLACK	12/4, SJO	3"	WHITE	26.5 LB [12.0 KG]
HBLI25124	IND REEL, UL TYPE 1, 25' SJO, 12/4, 20A MAX. 250V	20A 250V	25 FT.	BLACK	12/4, SJO	3"	WHITE	24.5 LB [11.1 KG]
HBLI45103	IND REEL, UL TYPE 1, 45' SJO, 10/3, 30A MAX. 250V	30A 250V	45 FT.	BLACK	10/3, SJO	4.75"	WHITE	32.4 LB [14.7 KG]
HBLI35103	IND REEL, UL TYPE 1, 35' SJO, 10/3, 30A MAX. 250V	30A 250V	35 FT.	BLACK	10/3, SJO	4.75"	WHITE	30.0 LB [13.6 KG]
HBLI25103	IND REEL, UL TYPE 1, 25' SJO, 10/3, 30A MAX. 250V	30A 250V	25 FT.	BLACK	10/3, SJO	3"	WHITE	26.0 LB [11.8 KG]
HBLI40104	IND REEL, UL TYPE 1, 40' SJO, 10/4, 30A MAX. 250V	30A 250V	40 FT.	BLACK	10/4, SJO	4.75"	WHITE	33.7 LB [15.3 KG]
HBLI35104	IND REEL, UL TYPE 1, 35' SJO, 10/4, 30A MAX. 250V	30A 250V	35 FT.	BLACK	10/4, SJO	4.75"	WHITE	32.2 LB [14.6 KG]
HBLI25104	IND REEL, UL TYPE 1, 25' SJO, 10/4, 30A MAX. 250V	30A 250V	25 FT.	BLACK	10/4, SJO	4.75"	WHITE	29.1 LB [13.2 KG]
HBLI45163Y	YL, IND REEL, UL TYPE 1, 45' SJO, 16/3, 10A MAX. 250V	10A 250V	45 FT.	BLACK	16/3, SJO	3"	YELLOW	22.9 LB [10.4KG]
HBLI35163Y	YL, IND REEL, UL TYPE 1, 35' SJO, 16/3, 10A MAX. 250V	10A 250V	35 FT.	BLACK	16/3, SJO	3"	YELLOW	22.0 LB [10.0KG]
HBLI25163Y	YL, IND REEL, UL TYPE 1, 25' SJO, 16/3, 10A MAX. 250V	10A 250V	25 FT.	BLACK	16/3, SJO	3"	YELLOW	21.2 LB [9.6 KG]
HBLI45164Y	YL, IND REEL, UL TYPE 1, 45' SJO, 16/4, 10A MAX. 250V	10A 250V	45 FT.	BLACK	16/4, SJO	3"	YELLOW	23.6 LB [10.7 KG]
HBLI35164Y	YL, IND REEL, UL TYPE 1, 35' SJO, 16/4, 10A MAX. 250V	10A 250V	35 FT.	BLACK	16/4, SJO	3"	YELLOW	22.7 LB [10.3 KG]
HBLI25164Y	YL, IND REEL, UL TYPE 1, 25' SJO, 16/4, 10A MAX. 250V	10A 250V	25 FT.	BLACK	16/4, SJO	3"	YELLOW	21.8 LB [9.9 KG]
HBLI45143Y	YL, IND REEL, UL TYPE 1, 45' SJO, 14/3, 15A MAX. 250V	15A 250V	45 FT.	BLACK	14/3, SJO	3"	YELLOW	24.0 LB [10.9 KG]
HBLI35143Y	YL, IND REEL, UL TYPE 1, 35' SJO, 14/3, 15A MAX. 250V	15A 250V	35 FT.	BLACK	14/3, SJO	3"	YELLOW	22.9 LB [10.4 KG]
HBLI25143Y	YL, IND REEL, UL TYPE 1, 25' SJO, 14/3, 15A MAX. 250V	15A 250V	25 FT.	BLACK	14/3, SJO	3"	YELLOW	21.8 LB [9.9 KG]
HBLI45144Y	YL, IND REEL, UL TYPE 1, 45' SJO, 14/4, 15A MAX. 250V	15A 250V	45 FT.	BLACK	14/4, SJO	3"	YELLOW	25.4 LB [11.5 KG]
HBLI35144Y	YL, IND REEL, UL TYPE 1, 35' SJO, 14/4, 15A MAX. 250V	15A 250V	35 FT.	BLACK	14/4, SJO	3"	YELLOW	24.0 LB [10.9 KG]
HBLI25144Y	YL, IND REEL, UL TYPE 1, 25' SJO, 14/4, 15A MAX. 250V	15A 250V	25 FT.	BLACK	14/4, SJO	3"	YELLOW	22.7 LB [10.3 KG]
HBLI45123Y	YL, IND REEL, UL TYPE 1, 45' SJO, 12/3, 20A MAX. 250V	20A 250V	45 FT.	BLACK	12/3, SJO	3"	YELLOW	26.5 LB [12.0 KG]
HBLI35123Y	YL, IND REEL, UL TYPE 1, 35' SJO, 12/3, 20A MAX. 250V	20A 250V	35 FT.	BLACK	12/3, SJO	3"	YELLOW	24.9 LB [11.3 KG]
HBLI25123Y	YL, IND REEL, UL TYPE 1, 25' SJO, 12/3, 20A MAX. 250V	20A 250V	25 FT.	BLACK	12/3, SJO	3"	YELLOW	23.4 LB [10.6 KG]
HBLI45124Y	YL, IND REEL, UL TYPE 1, 45' SJO, 12/4, 20A MAX. 250V	20A 250V	45 FT.	BLACK	12/4, SJO	4.75"	YELLOW	29.8 LB [13.5 KG]
HBLI35124Y	YL, IND REEL, UL TYPE 1, 35' SJO, 12/4, 20A MAX. 250V	20A 250V	35 FT.	BLACK	12/4, SJO	3"	YELLOW	26.5 LB [12.0 KG]
HBLI25124Y	YL, IND REEL, UL TYPE 1, 25' SJO, 12/4, 20A MAX. 250V	20A 250V	25 FT.	BLACK	12/4, SJO	3"	YELLOW	24.5 LB [11.1 KG]
HBLI45103Y	YL, IND REEL, UL TYPE 1, 45' SJO, 10/3, 30A MAX. 250V	30A 250V	45 FT.	BLACK	10/3, SJO	4.75"	YELLOW	32.4 LB [14.7 KG]
HBLI35103Y	YL, IND REEL, UL TYPE 1, 35' SJO, 10/3, 30A MAX. 250V	30A 250V	35 FT.	BLACK	10/3, SJO	4.75"	YELLOW	30.0 LB [13.6 KG]
HBLI25103Y	YL, IND REEL, UL TYPE 1, 25' SJO, 10/3, 30A MAX. 250V	30A 250V	25 FT.	BLACK	10/3, SJO	3"	YELLOW	26.0 LB [11.8 KG]
HBLI40104Y	YL, IND REEL, UL TYPE 1, 40' SJO, 10/4, 30A MAX. 250V	30A 250V	40 FT.	BLACK	10/4, SJO	4.75"	YELLOW	33.7 LB [15.3 KG]
HBLI35104Y	YL, IND REEL, UL TYPE 1, 35' SJO, 10/4, 30A MAX. 250V	30A 250V	35 FT.	BLACK	10/4, SJO	4.75"	YELLOW	32.2 LB [14.6 KG]
HBLI25104Y	YL, IND REEL, UL TYPE 1, 25' SJO, 10/4, 30A MAX. 250V	30A 250V	25 FT.	BLACK	10/4, SJO	4.75"	YELLOW	29.1 LB [13.2 KG]
HBLIWC45123	YL, IND REEL, UL TYPE 1, 45' SJO, 12/3, 20A MAX. 250V	20A 250V	45 FT.	WHITE	12/3 SJO	3"	WHITE	26.5 LB [12.0 KG]

LIST OF PARTS		
DESCRIPTION	MATERIAL	FINISH
SPOOL WITH RATCHET	ALUMINIUM	POWDER COATING
SPOOL	ALUMINIUM	POWDER COATING
WIRING CHAMBER COVER	ALUMINIUM	POWDER COATING
SPRING BOX COVER	STEEL	ZINC PLATE
CLOCKWORK SPRING	SPRING STEEL	
GUIDE ARM	ALUMINIUM	POWDER COATING
GUIDE FRAME	THERMOPLASTIC	
HARDWARE	STEEL	ZINC PLATE
SPINDLE	STEEL	ZINC PLATE
CORD	COPPER	
BALL STOPPER	THERMOPLASTIC	
INTERNAL TERMINALS	COPPER ALLOY	
FITTING	ALUMINIUM	

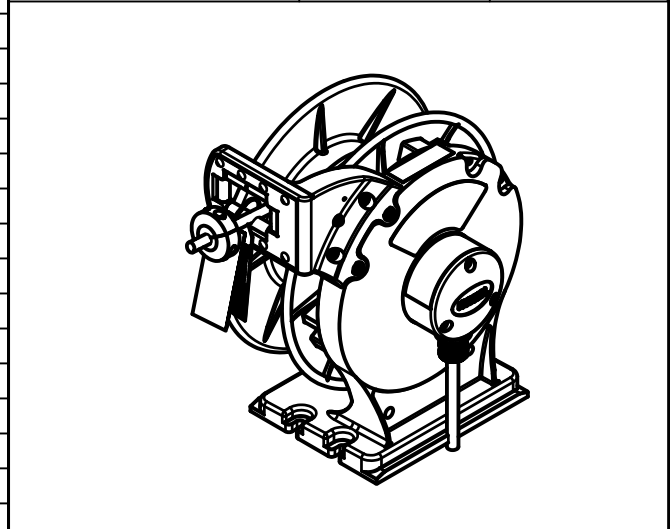

REV	DESCRIPTION	APP	DATE
3	TABLE, ADDED CORD COLOR COLUMN. ADDED HBLIWC45123. 3.0" REEL REMOVED BLACK FROM CALLOUT. PER DCN 190617123304 SPN	WO	6/18/19
2	ADDED ISO VIEW PER DCN #190321101330. D.LI		4/18/2019
1	NEW RELEASE PER DCN #24214. D.LI		8/7/2018

THE DESIGN AND DIMENSIONS OF THE PRODUCT SHOWN ON THIS DRAWING ARE SUBJECT TO CHANGE WITHOUT NOTICE. DIMENSIONS ARE IN INCHES [mm].

TITLE
REEL WITH OPEN CORD END, UL TYPE 1

HUBBELL
WIRING DEVICE-KELLEMS
HUBBELL INCORPORATED
SHELTON, CT

TOLERANCES UNLESS OTHERWISE SPECIFIED
.XX = ±.01
.XXX = ±.005
ANGLE TOL. ±2'

DR. BY VD SCALE 1:8
CHK. BY MA DATE 02/02/2018

DIMENSION SHEET FOR CAT. NO. M-13840
SEE TABLE
B
3