

M-13362

1

CAT. NO.	CONFIG.	RATING	HOUSING COLOR
HBLS4100C5W		100A 600 VAC 3Ø 50 HP	BLACK
HBLS4100C6W		100A 380-415 VAC 15 HP	RED
HBLS4100C7W		100A 480 VAC 3Ø 40 HP	RED
HBLS4100C9W		100A 250 VAC 3Ø 15 HP	BLUE
HBLS4100C12W		100A 125/250 VAC L-L 208-250 VAC 10 HP L-N 125 VAC 3 HP	ORANGE
HBLS5100C5W		100A 347/600 VAC 3Ø 50 HP	BLACK
HBLS5100C6W		100A 200/346 - 240/415 VAC 15 HP	RED
HBLS5100C7W		100A 277/480 VAC 3Ø 40 HP	RED
HBLS5100C9W		100A 120/208 VAC 3Ø 15 HP	BLUE

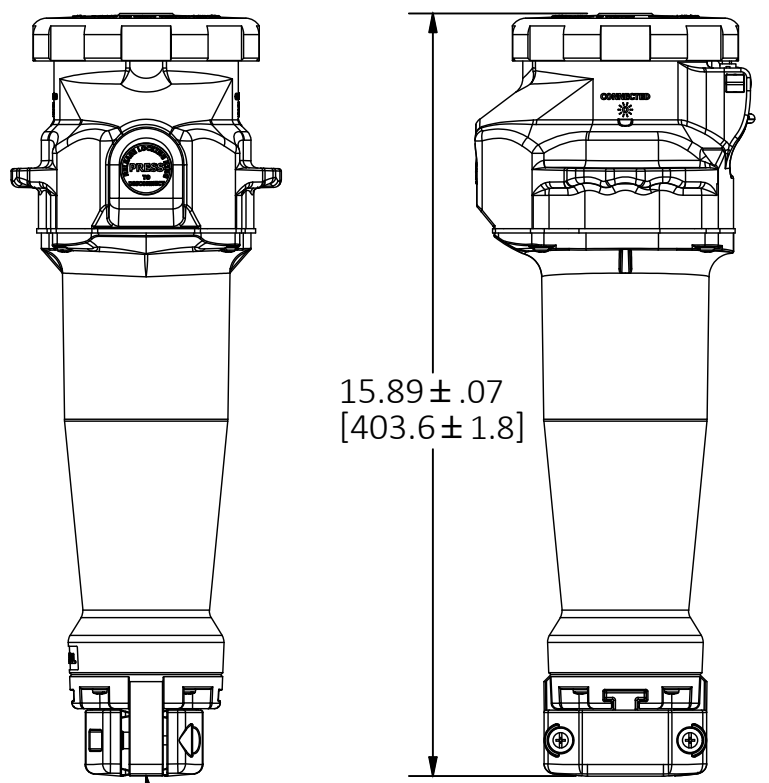
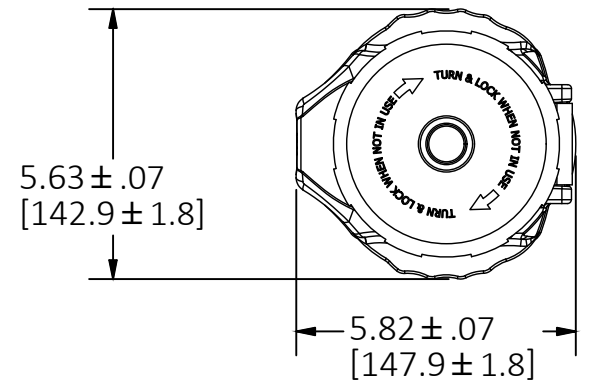

CABLE DIA. RANGE:
.90" MIN. / 1.88" MAX.
23mm / 48mm

LIST OF PARTS

DESCRIPTION	MATERIAL	FINISH
HOUSING	PBT	
GASKET	RUBBER	
LOCKING RING	PBT	
INTERIOR	NYLON	
PHASE, NEUTRAL & GND PIN CONTACTS	BER, COPPER	SILVER
PHASE & NEUTRAL CONTACTS	SILVER ALLOY	
TERM. SCREWS	ST. STEEL	
GLAND CAP	PBT	
GLANDS	RUBBER	
CLAMPS	PBT	
CLAMP NUTS	BRASS	NICKEL
ASSY SCREWS	ST. STEEL	
LED WINDOW	POLYCARBONATE	

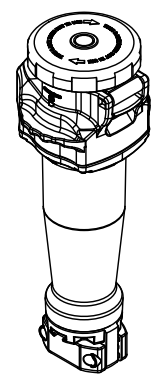

1	INITIAL RELEASE PER DCN 23444 WHD		12/5/17
REV	DESCRIPTION	APP	DATE

THE DESIGN AND DIMENSIONS OF THE PRODUCT SHOWN ON THIS DRAWING ARE SUBJECT TO CHANGE WITHOUT NOTICE. DIMENSIONS ARE IN INCHES [mm].

TITLE
100A 3P/4W & 4P/5W PIN AND SLEEVE SWITCHED CONNECTORS

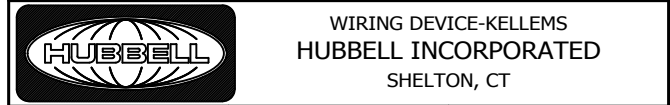

TOLERANCES UNLESS OTHERWISE SPECIFIED .XX = ± .01 .XXX = ± .005 ANGLE TOL. ±2'	DR. BY WHD	SCALE 1/4
	CHK. BY	DATE 12/5/17

DIMENSION SHEET FOR CAT. NO. SEE TABLE

B

M-13362

1