

M-10575 1

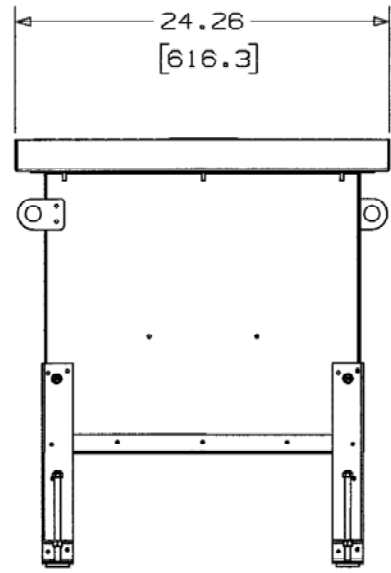
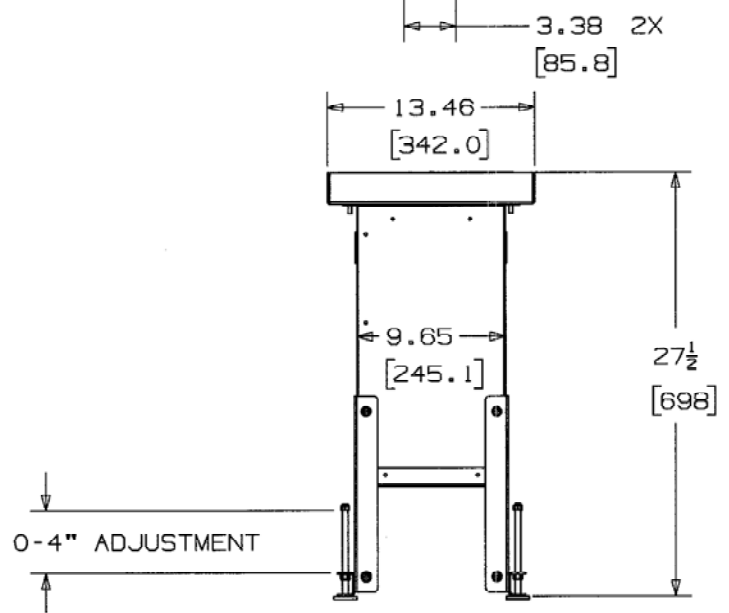
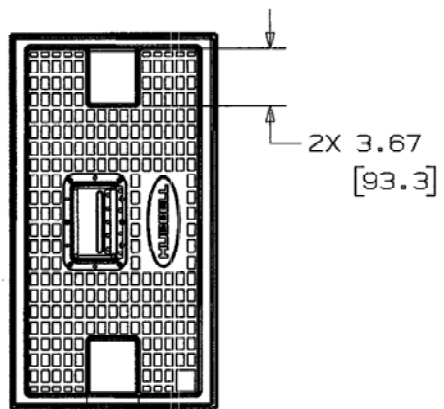

LIST OF PARTS		
DESCRIPTION	MATERIAL	FINISH
COVER ASSEMBLY	ALUMINUM	CLEAR COAT
BOX	GALV. STEEL/SS	POWDERCOAT OPT.
LEGS	GALV. STEEL/SS	POWDERCOAT OPT.
CONCRETE COVER	GALV. STEEL	N/A

REV	DESCRIPTION	APP	DATE
1	RELEASED PER DCN 13666	SM	4/3/07
	REVISIONS	APP	DATE

THE DESIGN AND DIMENSIONS OF THE PRODUCT SHOWN ON THIS DRAWING ARE SUBJECT TO CHANGE WITHOUT NOTICE

TITLE  
 AIR/WATER BOX  
 BOX ASSEMBLY  
 (STANDALONE UNIT)

TOLERANCES UNLESS OTHERWISE SPECIFIED	WIRING DEVICE-KELLEMS HUBBELL INCORPORATED BRIDGEPORT, CT	
FRACTIONS ± 1/84	DR. BY MSS	APP. BY SM
DECIMALS ± .005	TR. BY	SCALE 1:8
ANGLES ± 2°	CHK'D BY SM	DATE 4/3/07

DIMENSION SHEET FOR CAT. NO.

REPAIRABLE  NON-REPAIRABLE

B

M-10575

1