

M-8607 5

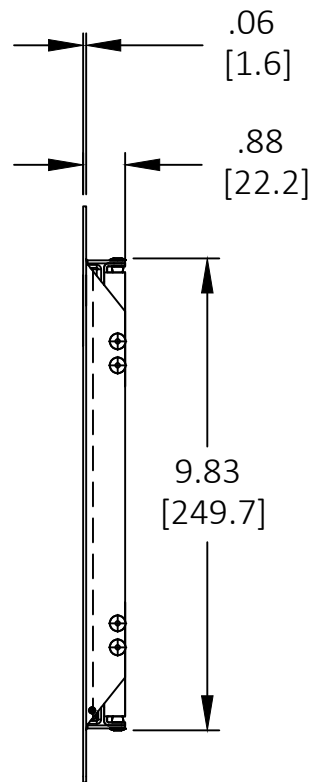
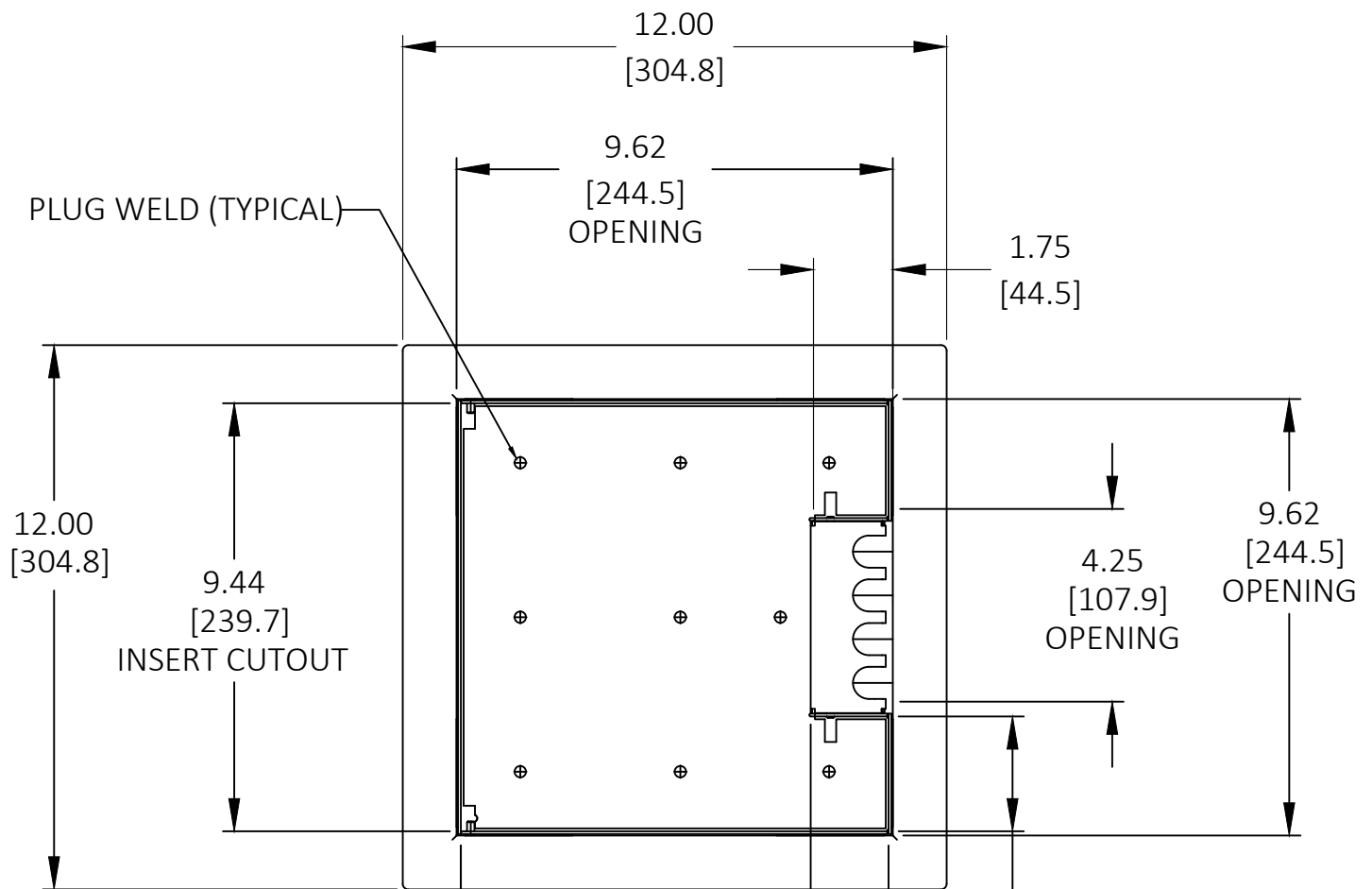
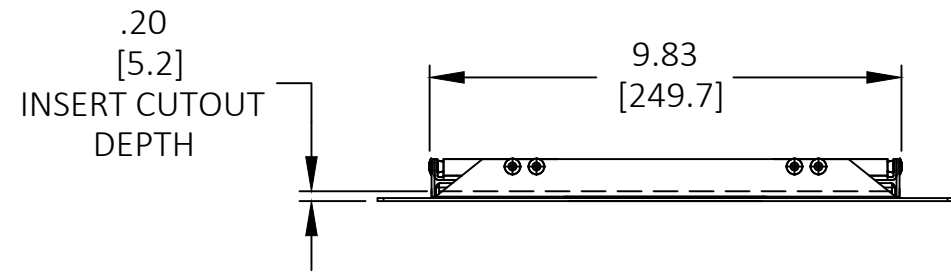

LIST OF PARTS		
DESCRIPTION	MATERIAL	FINISH
COVER	STEEL	PAINTED PRE-GALV.
GASKET	RUBBER	BLACK
MTG SCREWS	STEEL	

DIMENSION SHEET FOR CAT. NO. SEE TABLE

5	REDRAWN TO ACAD; UPDATED DRAWING VIEWS & DIM'S TO MATCH CURRENT PRODUCT DESIGN; ADDED INSERT CUTOUT DIMENSIONS; REMOVED CAT. NUMBERS FROM DRAWING TITLE. PER DCN 23675 RM	DDL	4/3/18
	REV	DESCRIPTION	APP DATE

THE DESIGN AND DIMENSIONS OF THE PRODUCT SHOWN ON THIS DRAWING ARE SUBJECT TO CHANGE WITHOUT NOTICE. DIMENSIONS ARE IN INCHES [mm].

TITLE
CUSTOMER DRAWING TRIM/COVER PLATE

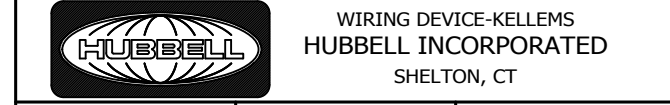

TOLERANCES UNLESS OTHERWISE SPECIFIED .XX = ± .01 .XXX = ± .005 ANGLE TOL. ± 2'	DR. BY	RM	SCALE	1/4
	CHK. BY	DDL	DATE	4/3/18

- NOTES:
1. REMOVED
 2. PRODUCT MUST MEET UL & CSA CONSTRUCTION, PERFORMANCE & MARKING REQUIREMENTS.
 3. THIS COVER USED WITH HBLAFB FLOOR BOXES.
 4. REMOVED
 5. MOUNTING SCREWS INCLUDED (NOT SHOWN).

CAT. NO.	FINISH
HBLTCGNT	GRANITE
HBLTCGNTBK	BLACK

B M-8607 **5**