

M-13475

1

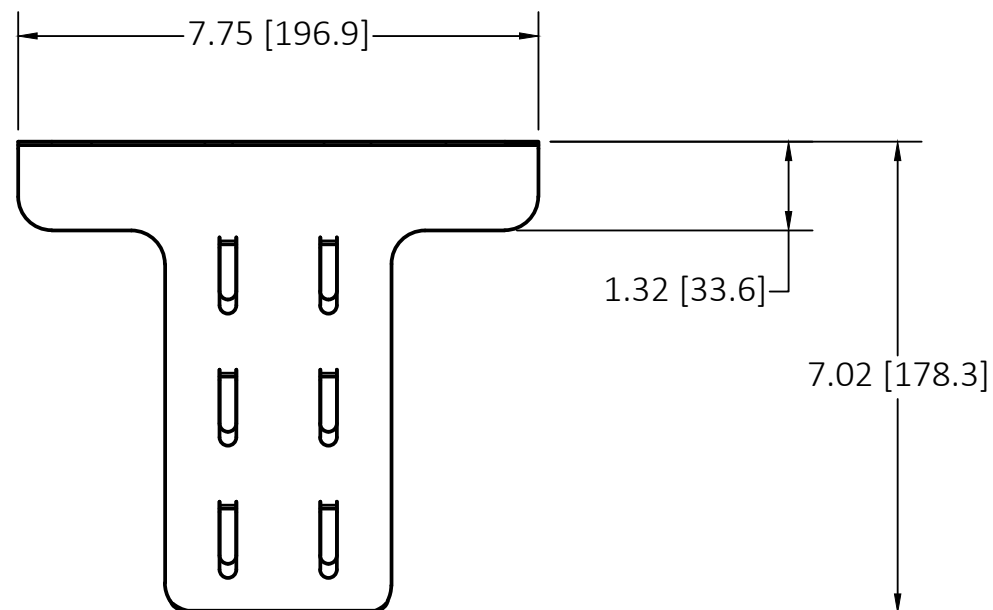

FINISH	CATALOG NUMBER
PRE-GALVANIZED	HBTCA3
BLACK	HBTCA3BK

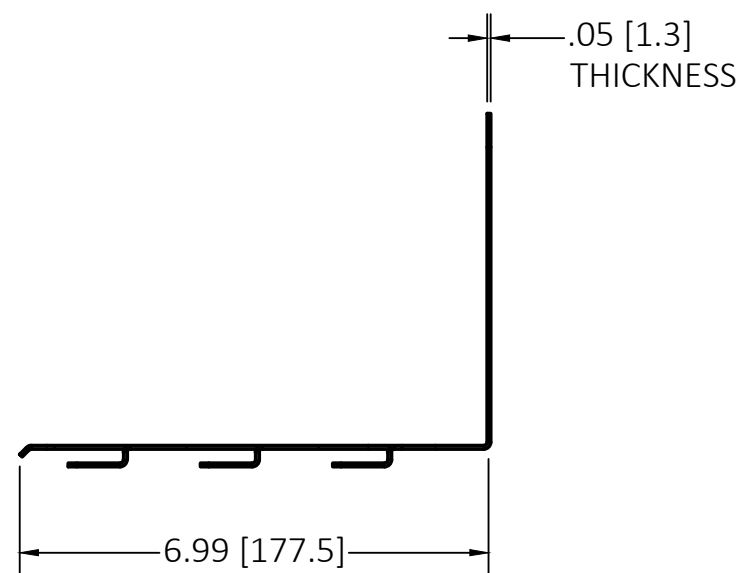
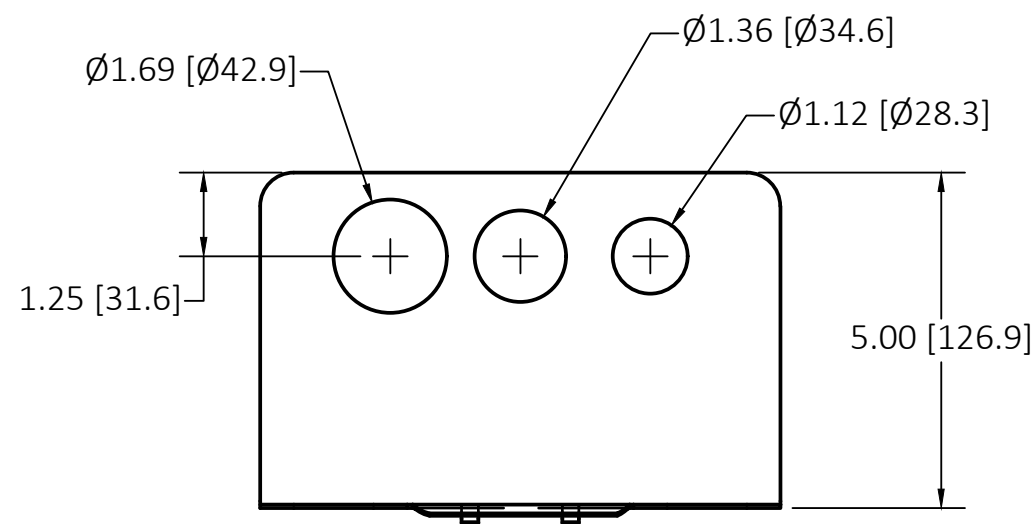

NOTES:

- 1. CONNECTS CONDUIT TO TRAY

LIST OF PARTS

DESCRIPTION	MATERIAL	FINISH
CONDUIT ATTACHMENT	GALV STEEL	SEE TABLE

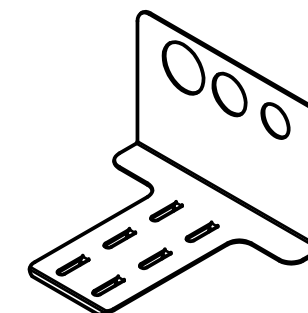

CATALOG NO. HBTCA3 (NOT SHOWN TO SCALE)

1	INITIAL DOCUMENT	DDL	11/15/16
	RELEASE PER DCN 22750		
REV	DESCRIPTION	APP	DATE

THE DESIGN AND DIMENSIONS OF THE PRODUCT SHOWN ON THIS DRAWING ARE SUBJECT TO CHANGE WITHOUT NOTICE. DIMENSIONS ARE IN INCHES [mm].

TITLE
CONDUIT ATTACHMENT

	WIRING DEVICE-KELLEMS HUBBELL INCORPORATED SHELTON, CT	
	DR. BY BJ	SCALE NONE
TOLERANCES UNLESS OTHERWISE SPECIFIED .XX = ± .01 .XXX = ± .005 ANGLE TOL. ± 2°	CHK. BY MN	DATE 08/16/16

DIMENSION SHEET FOR CAT. NO. M-13475

B

M-13475

1