

M-13513

1

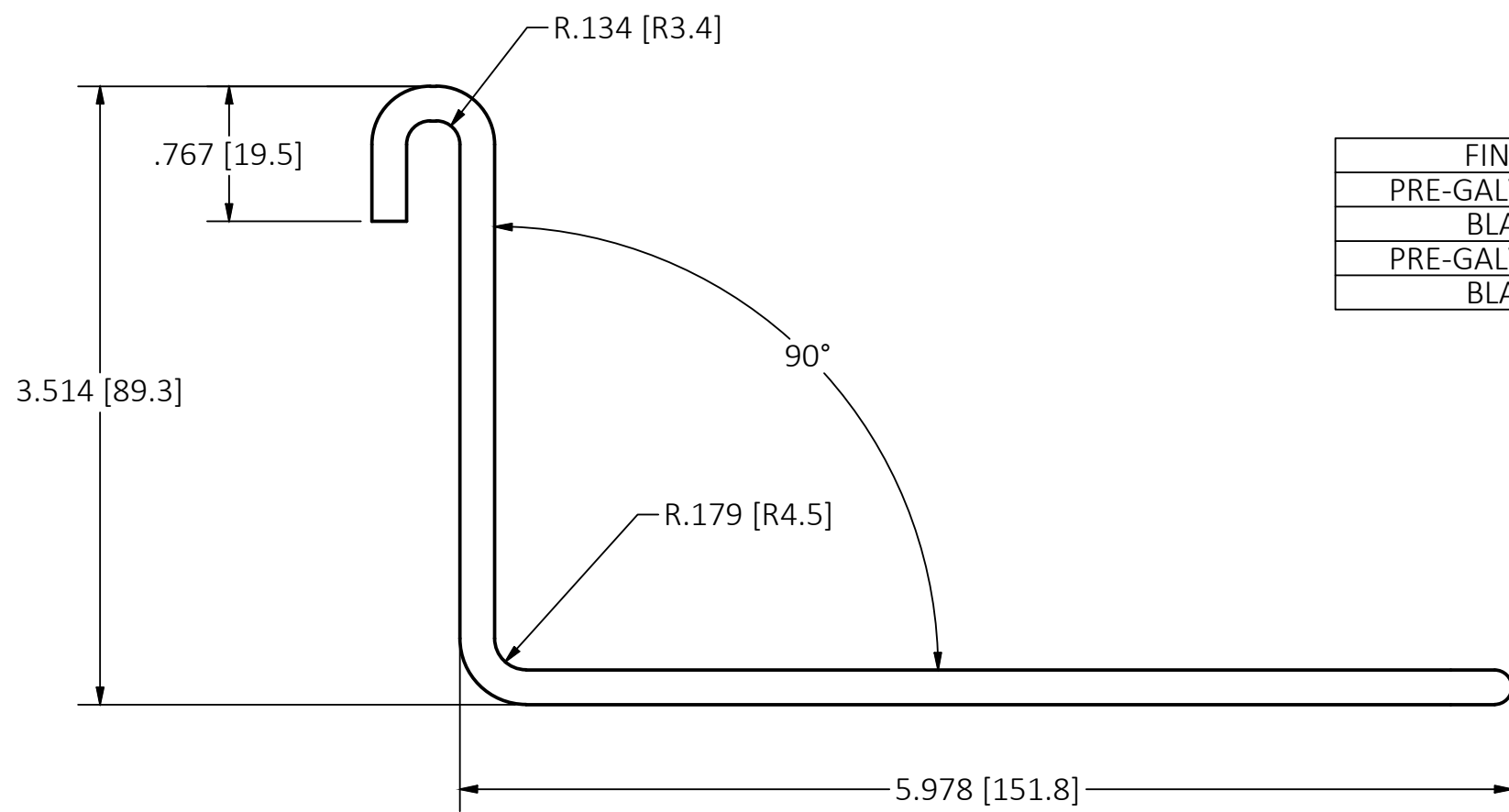
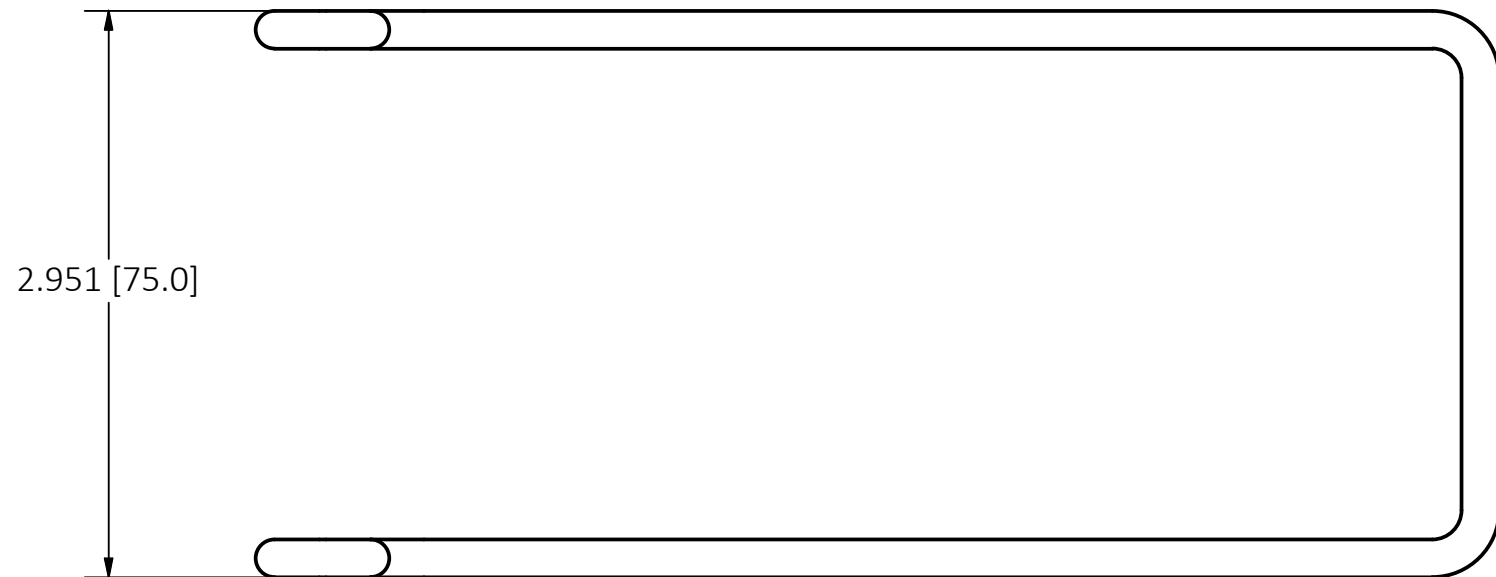

FINISH	CATALOG NUMBER
PRE-GALVANIZED	HBTF A2
BLACK	HBTF A2BK
PRE-GALVANIZED	HBTF A46
BLACK	HBTF A46BK

LIST OF PARTS

DESCRIPTION	MATERIAL	FINISH
FITTING ATTACHMENT	GALV STEEL	SEE TABLE

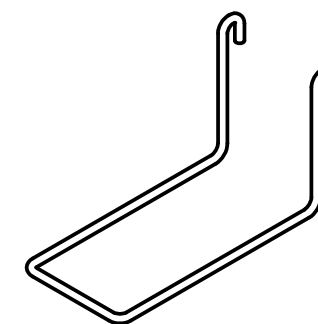

CATALOG NO. HBTF A46
(NOT SHOWN TO SCALE)

1	INITIAL DOCUMENT RELEASE PER DCN 22750	DDL	11/15/16
REV	DESCRIPTION	APP	DATE

THE DESIGN AND DIMENSIONS OF THE PRODUCT SHOWN ON THIS DRAWING ARE SUBJECT TO CHANGE WITHOUT NOTICE. DIMENSIONS ARE IN INCHES [mm].

TITLE

FITTING ATTACHMENT



WIRING DEVICE-KELLEMS
HUBBELL INCORPORATED
SHELTON, CT

TOLERANCES UNLESS OTHERWISE SPECIFIED
.XX = ±.01
.XXX = ±.005
ANGLE TOL. ±2°

DR. BY BJ
CHK. BY MN

SCALE NONE
DATE 08/16/16

NOTES

- 1. FILLS THE GAP IN TRAY WHEN CREATING FITTINGS IN 2" TRAY OR 4"/6" TRAY
- 2. WIRE DIAMETER: .197 [5.0]