

M-13503

1

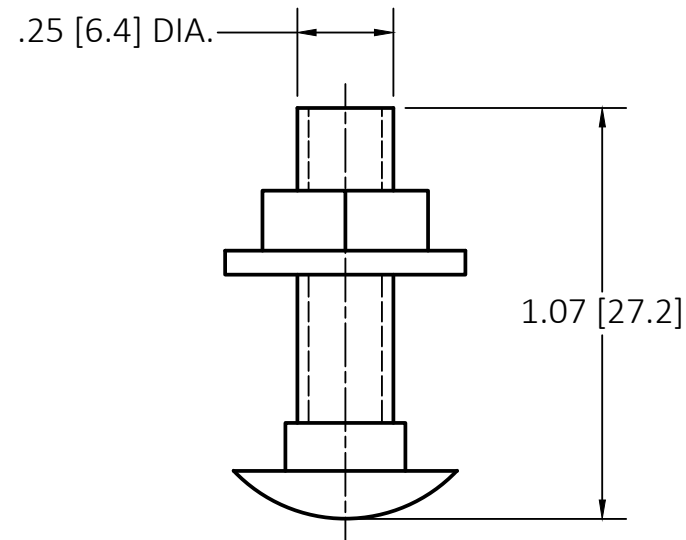

FINISH	CATALOG NUMBER
ZINC PLATED	HBTNB
STAINLESS STEEL	HBTNBSS

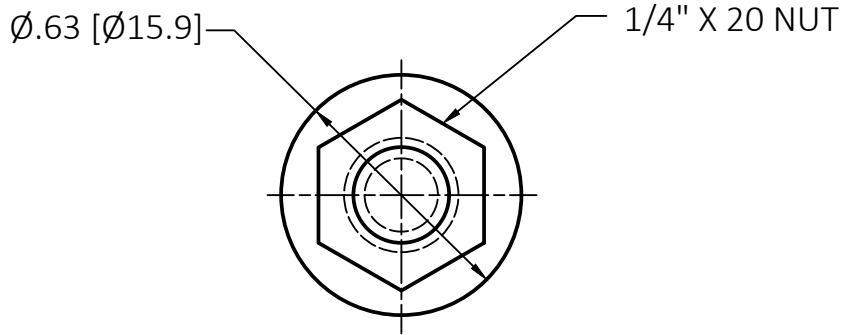
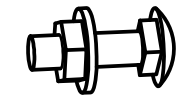

CATALOG NO. HBTNB  
(NOT SHOWN TO SCALE)

LIST OF PARTS		
DESCRIPTION	MATERIAL	FINISH
NUT AND BOLT SET	STEEL	SEE TABLE

1	INITIAL DOCUMENT RELEASE PER DCN 22750	DDL	11/15/16
REV	DESCRIPTION	APP	DATE

THE DESIGN AND DIMENSIONS OF THE PRODUCT SHOWN ON THIS DRAWING ARE SUBJECT TO CHANGE WITHOUT NOTICE. DIMENSIONS ARE IN INCHES [mm].

TITLE  
**NUT AND BOLT SET**

 WIRING DEVICE-KELLEMS  
HUBBELL INCORPORATED  
SHELTON, CT

TOLERANCES UNLESS OTHERWISE SPECIFIED .XX = ±.01 .XXX = ±.005 ANGLE TOL. ±2°	DR. BY BJ CHK. BY MN	SCALE NONE DATE 08/16/16
---	-------------------------	-----------------------------

**NOTES:**  
1. 1/4"-20 NUT AND BOLT SETS 50 PER BOX

DIMENSION SHEET FOR CAT. NO. SEE TABLE

**B**

**M-13503**

**1**