

M-13569

1

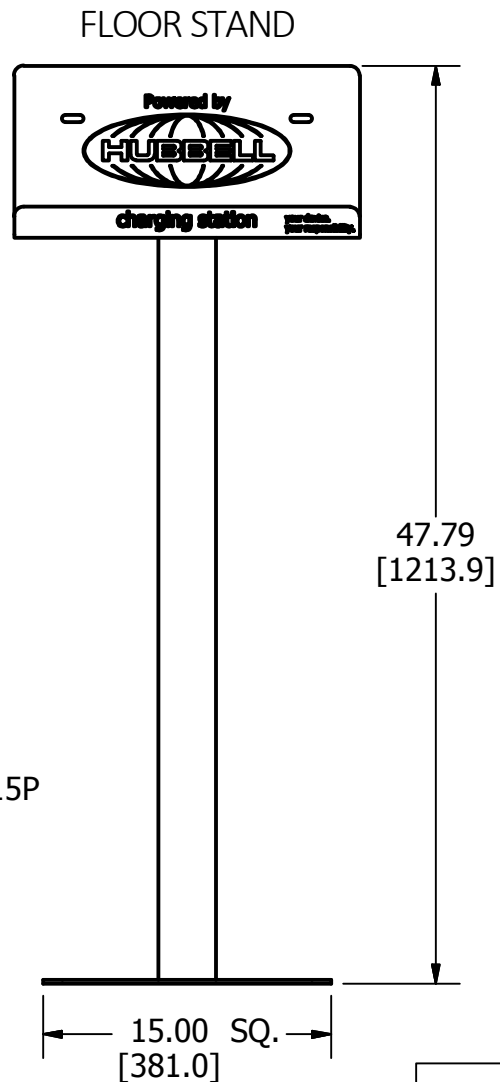

MOUNTING HOLES (WALL MOUNT)

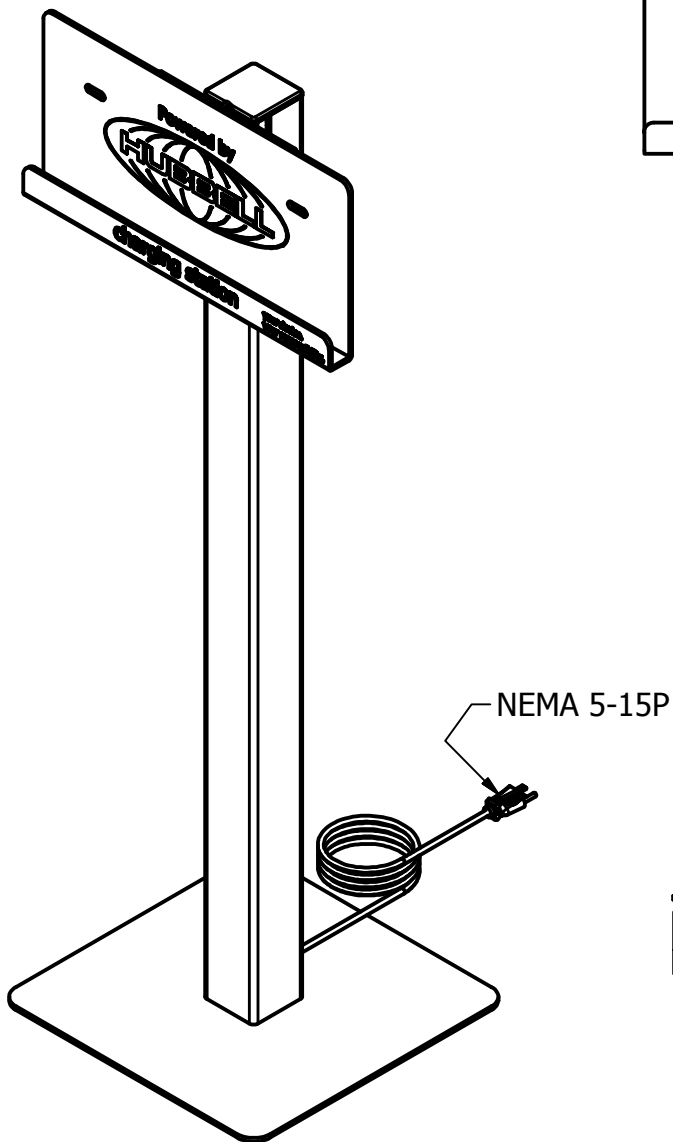
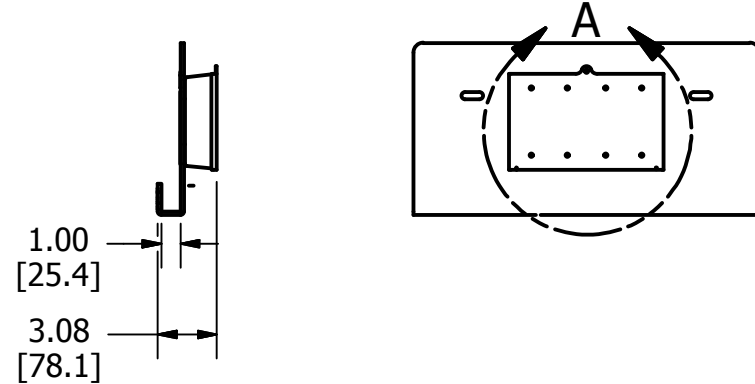
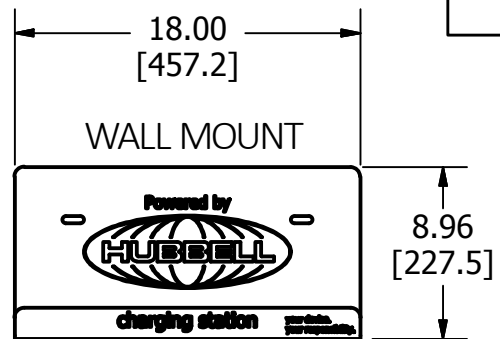
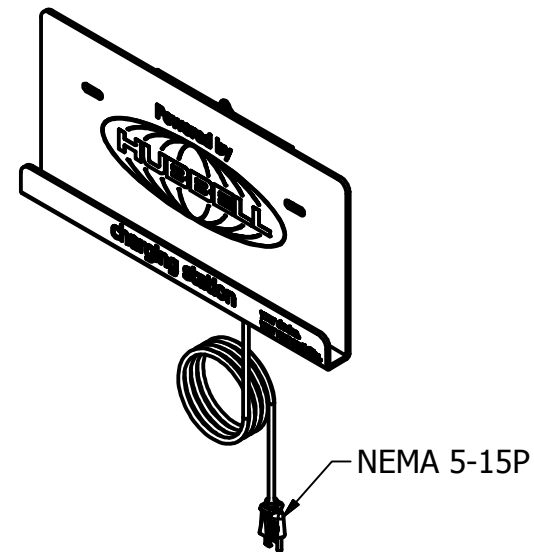
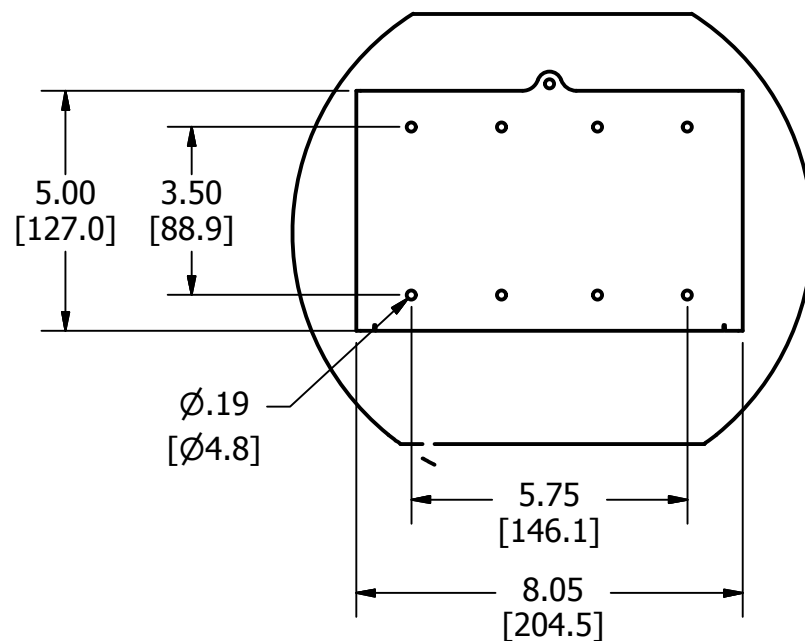

ORDER BLANK VERSIONS & SPECIFY CUSTOM GRAPHICS FOR SPECIALTY BRANDING

Catalog #	Description	Form Factor	Graphics
HCSFSBLANK	CHARGING STATION	FLOOR STAND	BLANK
HCSFS	CHARGING STATION	FLOOR STAND	HUBBELL
HCSWMBLANK	CHARGING STATION	WALL MOUNT	BLANK
HCSWM	CHARGING STATION	WALL MOUNT	HUBBELL
HCSLOGOXXX	SPECIALTY GRAPHICS	-	CUSTOM
HCSWMREPWMKIT	WALL MOUNT HARDWARE KIT	-	-
HCSREPFKIT	REPLACEMENT STAND (W/ POWER SUPPLY)	-	-

LIST OF PARTS

DESCRIPTION	MATERIAL	FINISH
STAND BASE	STEEL	POWDER COAT
TUBING	STEEL	POWDER COAT
TUBING CAP	THERMOPLASTIC	
WALL MOUNT	STEEL	POWDER COAT
ELEC. HOUSING	THERMOPLASTIC	

1	INITIAL RELEASE PER DCN 22901 DJR 2/13/2017	DJR	2/13/2017
REV	DESCRIPTION	APP	DATE

THE DESIGN AND DIMENSIONS OF THE PRODUCT SHOWN ON THIS DRAWING ARE SUBJECT TO CHANGE WITHOUT NOTICE. DIMENSIONS ARE IN INCHES [mm].

TITLE  
**CHARGING STATION**

WIRING DEVICE-KELLEMS  
HUBBELL INCORPORATED  
SHELTON, CT

TOLERANCES UNLESS OTHERWISE SPECIFIED .XX = ±.01 .XXX = ±.005 ANGLE TOL. ±2°	DR. BY DJR CHK. BY DJR	SCALE 1/10 DATE 2/13/2017
---	---------------------------	------------------------------