

M-12475 1

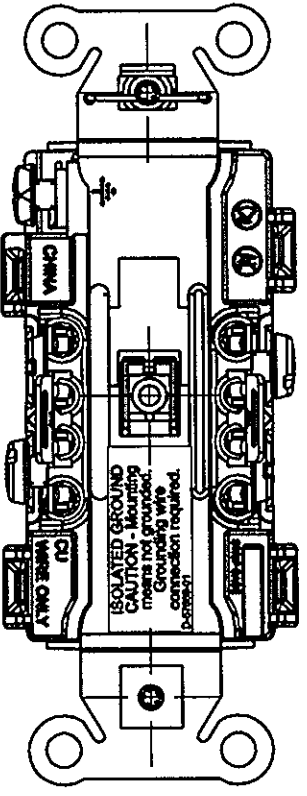
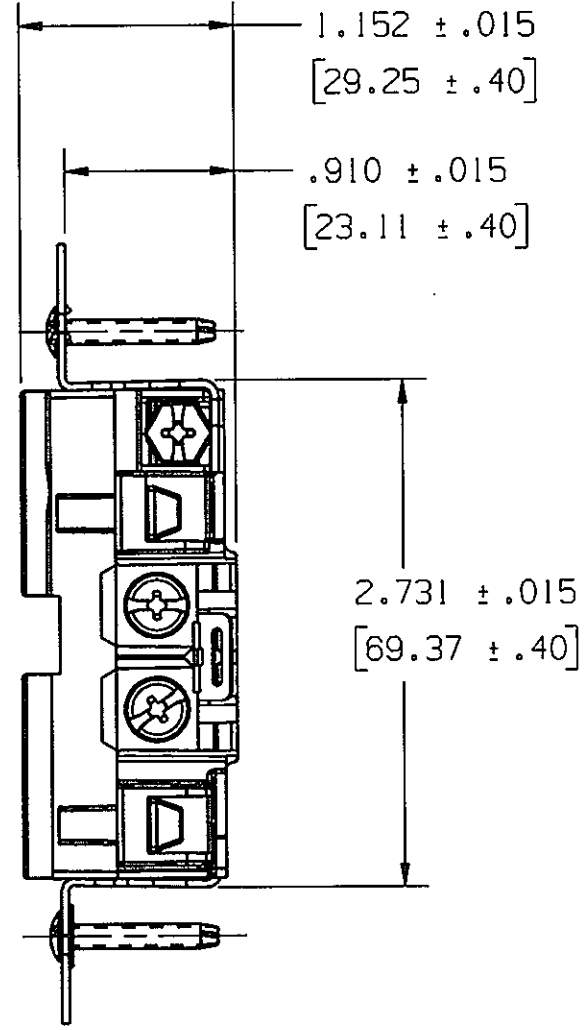
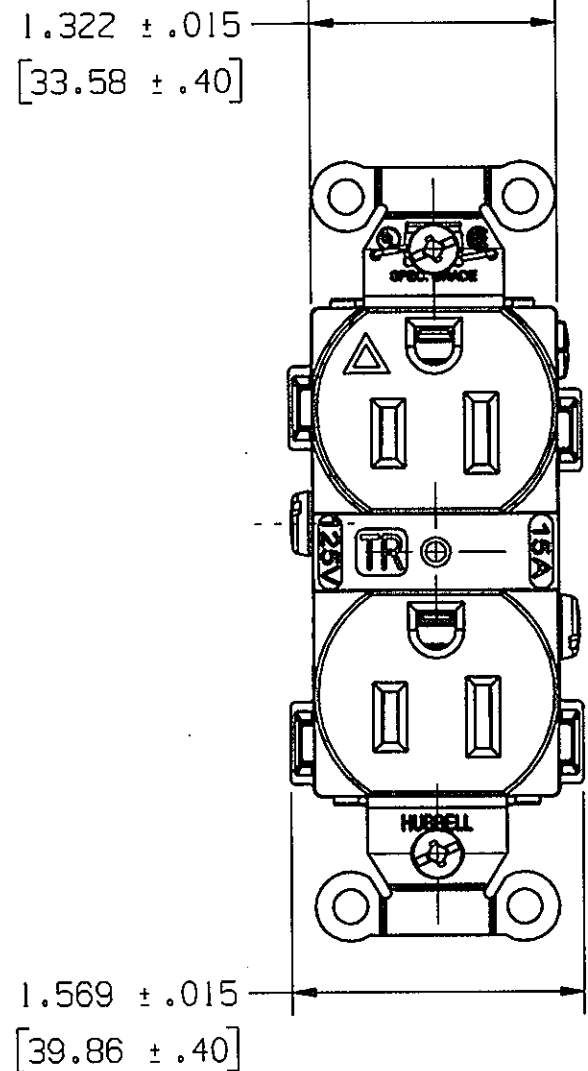

- NOTES:
 1) DIMENSIONS ARE IN INCHES (MM).
 2) ALL DEVICES UL LISTED AND CSA CERTIFIED.
 3) TERMINALS ACCOMMODATE #14-#10 AWG COPPER WIRE ONLY.

CATALOG NUMBERS											
HUBBELL	BROWN	IVORY	GRAY	WHITE	BLACK	ALMOND	BLUE	LIGHT ALMOND	RED	ORANGE	OFFICE WHITE
.....	1G52521TR	1G5252WTR	1G5252TR

LIST OF PARTS		
DESCRIPTION	MATERIAL	FINISH
TOP	NYLON 6/6	SEE TABLE
BASE	NYLON 6/6	BLACK
LINE CONTACTS	BRASS	
GROUND CONTACTS	BRASS	
CONTACT SCREW(NEU)	STEEL	NI PLT
CONTACT SCREW(HOT)	STEEL	
BRIDGE	.04 GALV STL	
GROUND SCREW	STEEL	GREEN
STAPLE	S.S.	
WASHER	PVC FILM	BLACK
MOUNTING SCREW	STEEL	SS
INSULATOR	MYLAR	

REPAIRABLE <input type="checkbox"/>	NON-REPAIRABLE <input type="checkbox"/>	B
-------------------------------------	---	----------

1	RELEASED PER DCN# 20044 MAM	TL	08/22/2012
SYM	REVISIONS	APP	DATE

THE DESIGN AND DIMENSIONS OF THE PRODUCT SHOWN ON THIS DRAWING ARE SUBJECT TO CHANGE WITHOUT NOTICE

TITLE HUBBELL
 15A 125V, 2P 3W,
 ISOLATED GROUND, TAMPER RESISTANT,
 DUPLEX RECEPTACLE,
 BACK & SIDE WIRE ONLY

TOLERANCES UNLESS OTHERWISE SPECIFIED .XX : ± .01 .XXX : ± .005 ANGLES : ± 2°	WIRING DEVICE-KELLEMS HUBBELL INCORPORATED SHELTON, CT	
	DR. BY MAM	APP. BY TLS
	TR. BY	SCALE 1:1
	CHK. BY	DATE 08/22/13

DIMENSION SHEET FOR CAT. NO.

REPAIRABLE NON-REPAIRABLE **B**

M-12475

1