

M-11793 1

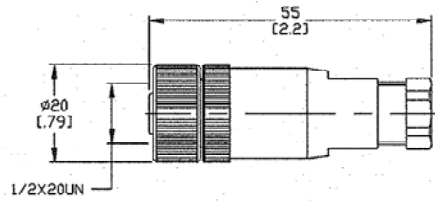

DIMENSIONS ARE INCHES [mm]

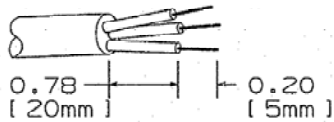

WIRE STRIP LENGTH

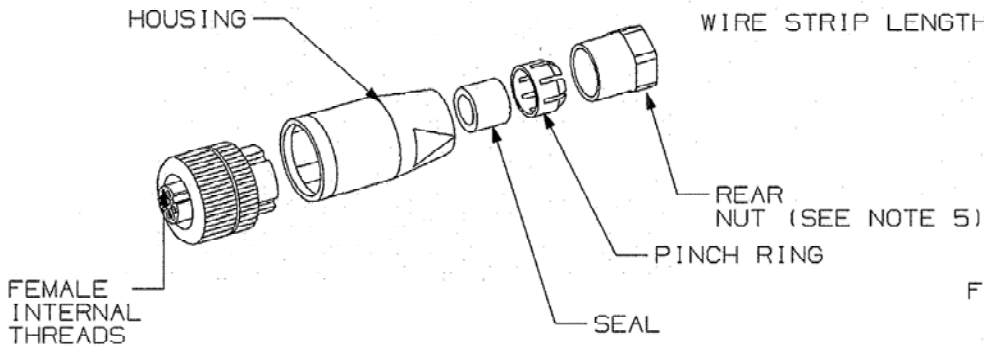

FACE VIEW 3P



Female

PINOUT AND COLOR CODE

- 1 GREEN
- 2 RED/BLACK TR
- 3 RED/WHITE TR

NOTES: UNLESS OTHERWISE SPECIFIED:

1. WIRE SIZE: 18AWG (0.75mm²) MAX.
2. ENCLOSURE RATING: IP67
3. OPERATING TEMPERATURE: -40°C TO 90°C.
4. c. us RECOGNIZED.
5. RECOMMENDED REAR NUT TORQUES
 F7 STYLE - 7-8 IN.LBS (80-100 Ncm)
 F9 STYLE - 7-8 IN.LBS (80-100 Ncm).
6. RECOMMENDED TERMINAL TORQUE
 3.54 IN.LBS (40Ncm)

CATALOG NO.	POLES	RATING	CABLE RANGE
MCMS23F7	3	250V/4A	0.16-0.24 IN.
MCMS23F9	3	250V/4A	0.24-0.32 IN.

LIST OF PARTS

DESCRIPTION	MATERIAL	FINISH
COUPLING NUT	BRASS	NICKEL PLATED
CONNECTOR SHELL	NYLON	BLACK
CONTACTS	BRASS	GOLD PLATED PALLADIUM NICKEL

SYM	REVISIONS	APP	DATE

1	12/11/10 NEW RELEASE PER DCN 17311 CAC		
---	--	--	--

THE DESIGN AND DIMENSIONS OF THE PRODUCT SHOWN ON THIS DRAWING ARE SUBJECT TO CHANGE WITHOUT NOTICE

TITLE STRAIGHT FEMALE MICRO QUICK THD. TYPE F7, F9

TOLERANCES UNLESS OTHERWISE SPECIFIED	WIRING DEVICE-KELLEMS HUBBELL INCORPORATED BRIDGEPORT, CT	
FRACTIONS ± 1/64	DR. BY CAC	APP. BY
DECIMALS ± .005	TR. BY	SCALE NONE
ANGLES ± 2'	CHK'D BY	DATE 12-2-10

DIMENSION SHEET FOR CAT. NO. SEE TABLE REPAIRABLE NON-REPAIRABLE M-11793 1