

M-12805

1

LIST OF PARTS

DESCRIPTION	MATERIAL	FINISH
SHELL/ENCLOSURE	PBT 15% GF	BLACK
SCREWS	STEEL	NICKEL
TERMINALS	COPPER	TIN
MAIN CONTACTS	BIMETAL COPPER/SILVER	

DIMENSION SHEET FOR CAT. NO. MD4P, MDNB, MDGB

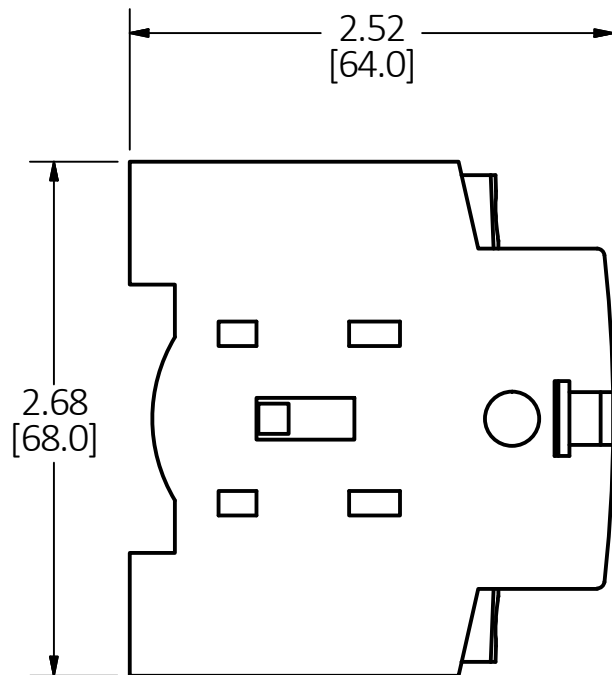
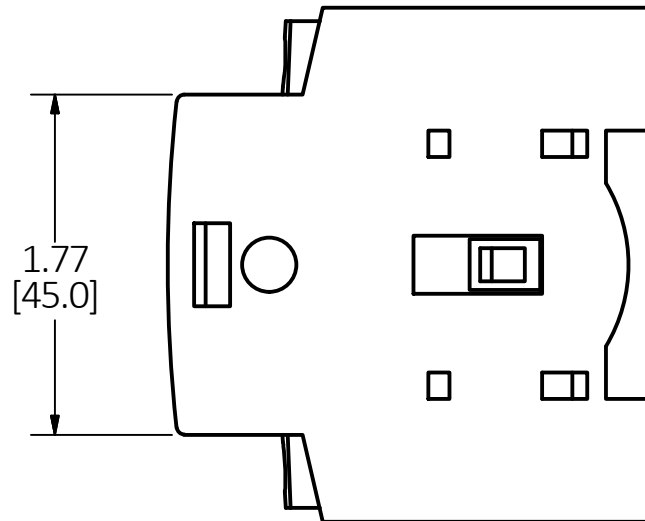
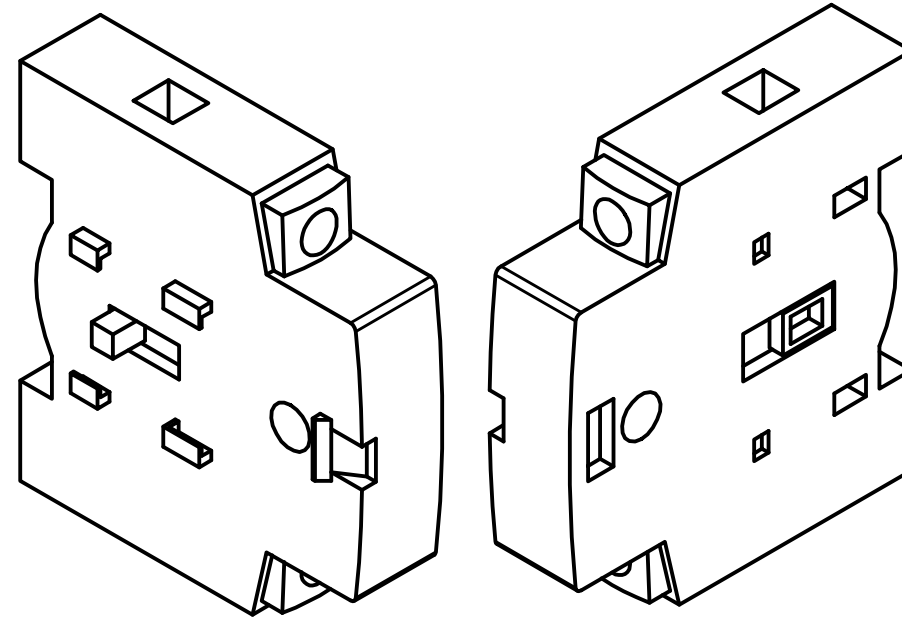
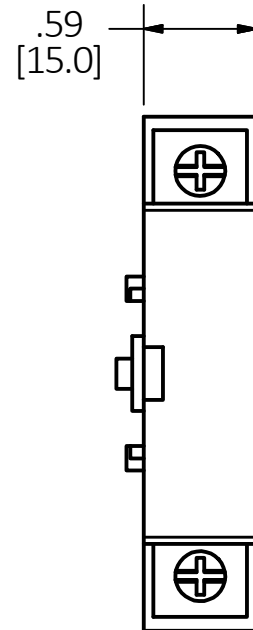
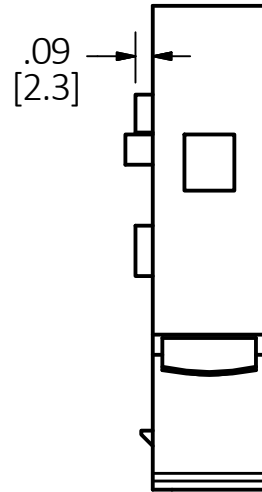

1	RELEASED PER DCN 22333	TLS	11/17/16
REV	DESCRIPTION	APP	DATE

THE DESIGN AND DIMENSIONS OF THE PRODUCT SHOWN ON THIS DRAWING ARE SUBJECT TO CHANGE WITHOUT NOTICE. DIMENSIONS ARE IN INCHES [mm].

TITLE CUSTOMER DRAWING,
30A HUBBELL-PRO MOTOR
DISCONNECT ACCESSORIES



WIRING DEVICE-KELLEMS
HUBBELL INCORPORATED
SHELTON, CT

TOLERANCES UNLESS OTHERWISE SPECIFIED
.XX = ±.01
.XXX = ±.005
ANGLE TOL. ±2°

DR. BY MAM
CHK. BY TLS

SCALE 1:1
DATE 10/18/16

NOTES:

- FOR USE WITH MD30 & MD40 SERIES MOTOR DISCONNECT SWITCHES ONLY.
- 14 - 4 AWG STRANDED OR 14 - 10 AWG SOLID COPPER WIRE ONLY, 75°C OR HIGHER.
- TIGHTEN TERMINAL SCREWS TO 26.5 in·lbs (3 N·m).
- SCREW HEAD TYPE: FLAT & POZIDRIV 2.
- cULus LISTED.

CAGE CODE 74545

CAT. NO.	DESCRIPTION
MD4P	ADDITIONAL SWITCHED POLE, 600V, 30A ONLY
MDNB	UNSWITCHED SOLID NEUTRAL POLE, 600V, 15-40A
MDBG	GROUND MODULE, 600V, 15-40A

B

M-12805

1