

M-13349 1

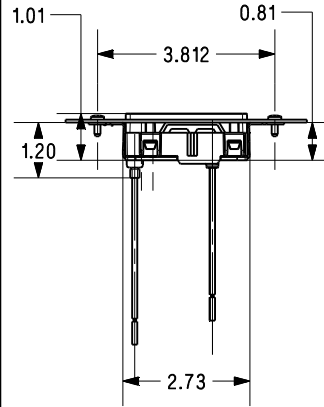
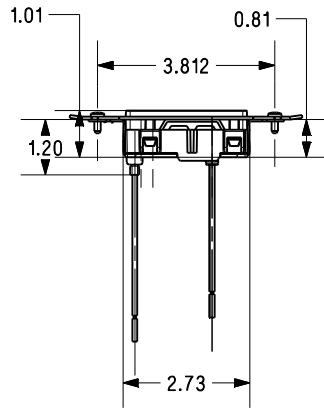
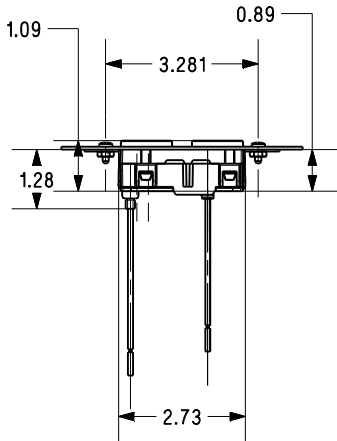
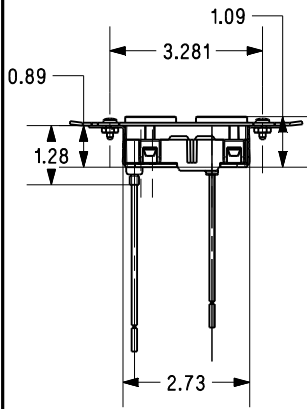
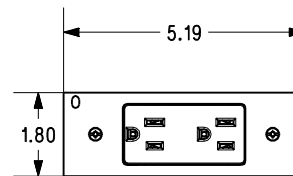
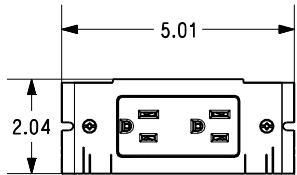
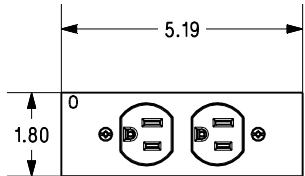
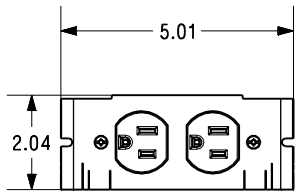

2,4,6 GANG DUPLEX  
15A DEVICES SHOWN, DIMENSIONS  
ARE THE SAME FOR 20A.

10 GANG DUPLEX  
15A DEVICES SHOWN, DIMENSIONS  
ARE THE SAME FOR 20A.

2,4,6 GANG STYLELINE  
15A DEVICES SHOWN, DIMENSIONS  
ARE THE SAME FOR 20A.

10 GANG STYLELINE  
15A DEVICES SHOWN, DIMENSIONS  
ARE THE SAME FOR 20A.

PWFBMPCR15GRYTR
PWFBMPCR20GRYTR
PWFBMPCR15GRY
PWFBMPCR20GRY

PWFB10MPCR15GRYTR
PWFB10MPCR20GRYTR
PWFB10MPCR15GRY
PWFB10MPCR20GRY

PWFBMPDR15GRY
PWFBMPDR20GRY
PWFBMPDR15GRYTR
PWFBMPDR20GRYTR

PWFB10MPDR15GRY
PWFB10MPDR20GRY
PWFB10MPDR15GRYTR
PWFB10MPDR20GRYTR

NOTES:  
1) cULus Listed.

CODE 74545

LIST OF PARTS

DESCRIPTION	MATERIAL	FINISH
FACEPLATE	CRS	PRE-GALVNZED
#12AWG WIRE	STRANDED	
#6-32 HEX NUT	STEEL	ZN PLATED
#6-32 SCREW	STEEL	ZN PLATED

1	RELEASED FOR PRODUCTION PER DCN 21955	CAC	03/02/16
SYM	REVISIONS	APP	DATE

THE DESIGN AND DIMENSIONS OF THE PRODUCT SHOWN ON THIS DRAWING ARE SUBJECT TO CHANGE WITHOUT NOTICE

TITLE LEADED RECEPTACLE & FACEPLATE ASSEMBLY	
TOLERANCES UNLESS OTHERWISE SPECIFIED	WIRING DEVICE-KELLEMS HUBBELL INCORPORATED SHELTON, CT
.XX : ±.01	DR. BY CAC APP. BY
.XXX : ±.005	TR. BY
ANGLES : ±2°	SCALE 3/8
	CHK. BY DATE 03-01-16

B M-13349 1