

M-10253 2

RW57300

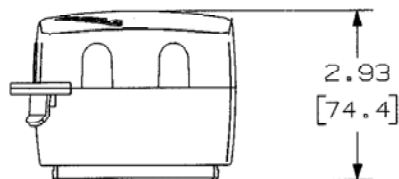

RW57350

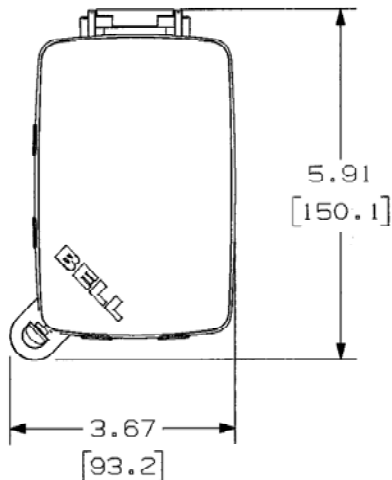
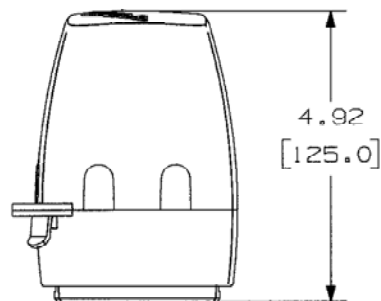
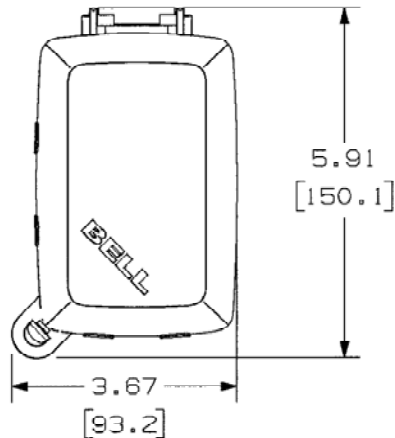

RW57350 SAME AS RW57300 EXCEPT AS SHOWN

- NOTES:
1. GASKET AND (4) MOUNTING SCREWS INCLUDED.
 2. MOUNTED VERTICALLY.
 3. DIMENSIONS ARE IN INCHES [MM].

OPTIONAL PLATES (INCLUDED)

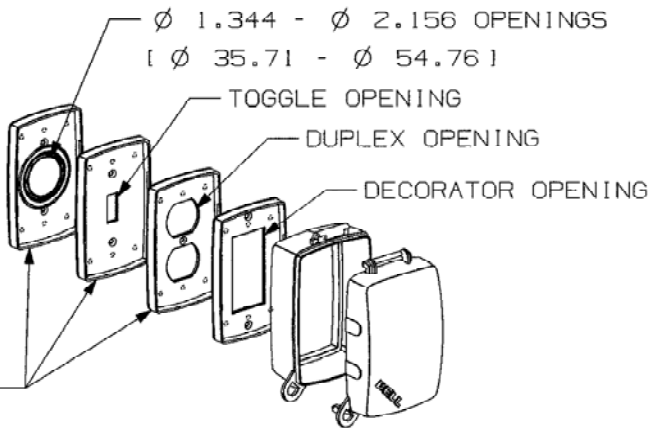

LIST OF PARTS

DESCRIPTION	MATERIAL	FINISH
COVER	POLYCARB	CLEAR
BACK	POLYCARB	GRAY
PLATES	POLYCARB	GRAY
GASKET	FOAM	BLACK
SCREW	STEEL	

2	REVISED NOTE 2; ADDED SINGLE TOGGLE PLATE; RW57300 WAS RW57500; RW57350 WAS RW57600; 3.67 WAS 4.32; 2.93 WAS 2.94; 4.92 WAS 4.92 PER DCN 15134 RCM	DJP	9/10/08
---	--	-----	---------

1	"X" REMOVED; LAST "X" REV. WAS "X-1" PER DCN #13326 AMZ	FJ	8/7/06
---	---	----	--------

SYM	REVISIONS	APP	DATE
-----	-----------	-----	------

THE DESIGN AND DIMENSIONS OF THE PRODUCT SHOWN ON THIS DRAWING ARE SUBJECT TO CHANGE WITHOUT NOTICE

TITLE
WEATHER RESISTANT COVER, IN-USE, 1-GANG

TOLERANCES UNLESS OTHERWISE SPECIFIED	WIRING DEVICE-KELLEMS HUBBELL INCORPORATED BRIDGEPORT, CT	
FRACTIONS ± 1/64	DR. BY AMZ	APP. BY FJ
DECIMALS ± .005	TR. BY	SCALE NONE
ANGLES ± 2°	CHK'D BY FJ	DATE 07/19/06

DIMENSION SHEET FOR CAT. NO. RW57300, RW57350
 REPAIRABLE NON-REPAIRABLE
 B M-10253 2