

M-11089 1

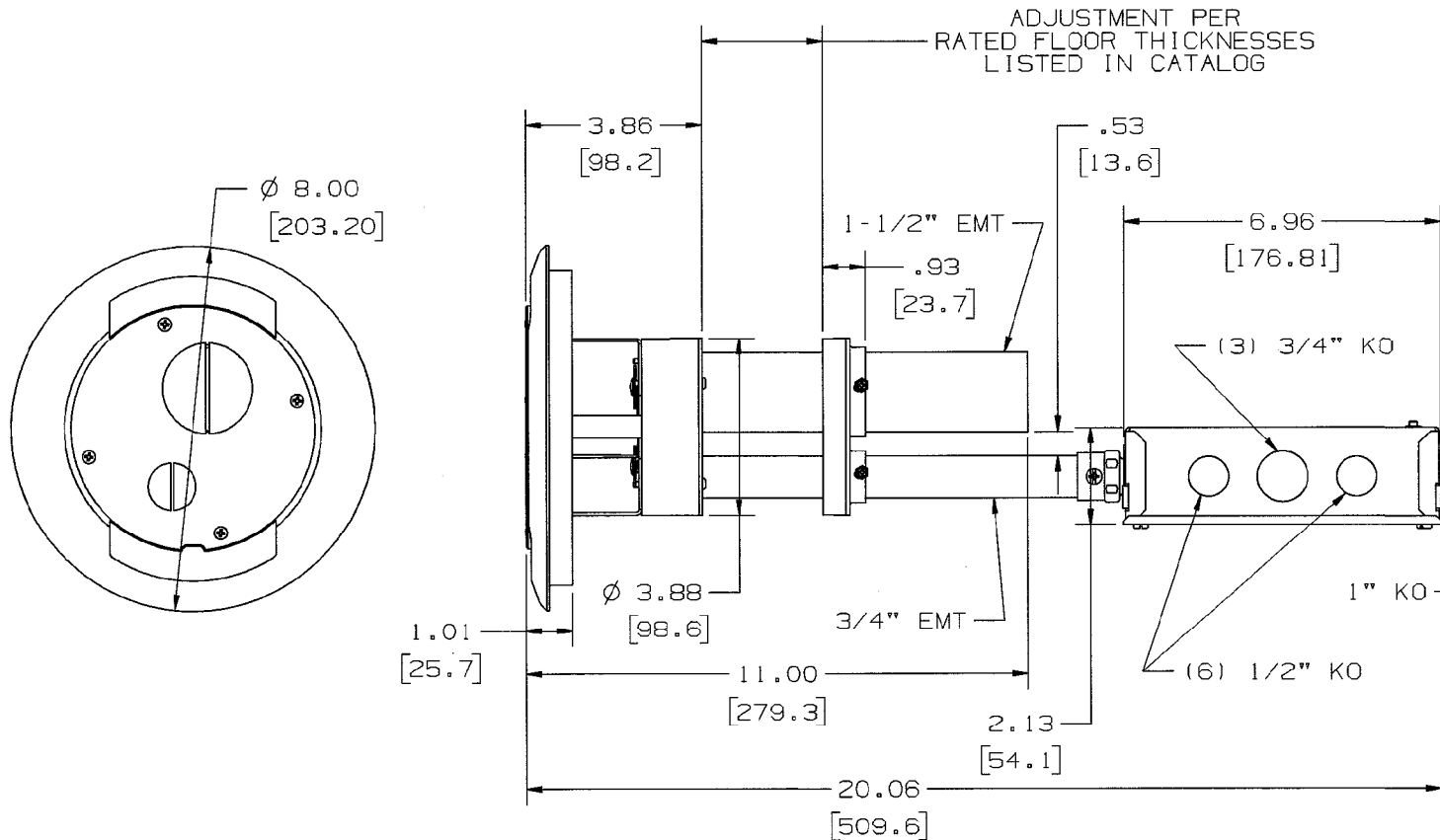

ADJUSTMENT PER
RATED FLOOR THICKNESSES
LISTED IN CATALOG

CATALOG NO.	DESCRIPTION
S1PTFFALJ	1 PC FURNITURE FEED, FRPT, ALUMINUM
S1PTFFBLJ	1 PC FURNITURE FEED, FRPT, BLACK
S1PTFFBRSJ	1 PC FURNITURE FEED, FRPT, BRASS
S1PTFFGYJ	1 PC FURNITURE FEED, FRPT, GRAY

DIMENSIONS IN INCHES [MM]

LIST OF PARTS

DESCRIPTION	MATERIAL	FINISH
CARPET FLANGE	CAST ALUM.	PAINT
(4) SCREW, COVER	STEEL	ZINC PLATE
FLOOR CUP SIDE/SIDE	GALV. CRS	NONE
(2) POSITION CLIP	STAIN. STL.	NONE
(2) SCREW, MTG. CLIP	STEEL	ZINC PLATE
FIRE BARRIER	LANCOTEX F992A	NONE
WIRING TUBE ASSY	NONE	NONE
(4) SCR, TORX PN. HD	STEEL	ZINC PLATE
GASKET, FLOOR	NEOPRENE	BLACK
SUB PLATE	CAST ALUM.	NONE
GASKET FLANGE	RUBBER	BLACK
DIVIDER	NYLON	NONE
FITTING ASSY	NONE	NONE
PLUG 1-1/2"	CAST ALUM.	NONE
PLUG 3/4"	CAST ZINC	NONE
DRIVE SCREW	STEEL	NONE
UNIVERSAL COVER ASM	CAST ALUM.	PAINT
COLLAR ASSEMBLY	GALV. CRS	NONE
JUNCTION BOX	STEEL	GALVANIZE
JUNCTION BOX COVER	STEEL	GALVANIZE
SCREW, #10-32 PAN HEAD	STEEL	ZINC P.L.T.
(2) SCREW, #6 PAN HD	STEEL	ZINC P.L.T.
3/4" CONDUIT ADAPTOR	STEEL	ZINC P.L.T.

DIMENSION SHEET FOR CAT. NO. SEE TABLE

REPAIRABLE

NON-REPAIRABLE

B

M-11089

1

1	NEW RELEASE PER DCN 14930 MSS	SM	6/23/08
SYM	REVISIONS	APP	DATE

THE DESIGN AND DIMENSIONS OF THE
PRODUCT SHOWN ON THIS DRAWING ARE
SUBJECT TO CHANGE WITHOUT NOTICE

TITLE SYSTEM ONE
FRPT ASSEMBLY
FURNITURE FEED

TOLERANCES UNLESS OTHERWISE SPECIFIED	WIRING DEVICE-KELLENS HUBBELL INCORPORATED BRIDGEPORT, CT	
	DR. BY MSS	APP. BY
FRACTIONS ±1/64	TR. BY	SCALE NONE
DECIMALS ±.005	CHK'D BY	DATE 6/23/08
ANGLES ±2'		