

M-11234 | 1

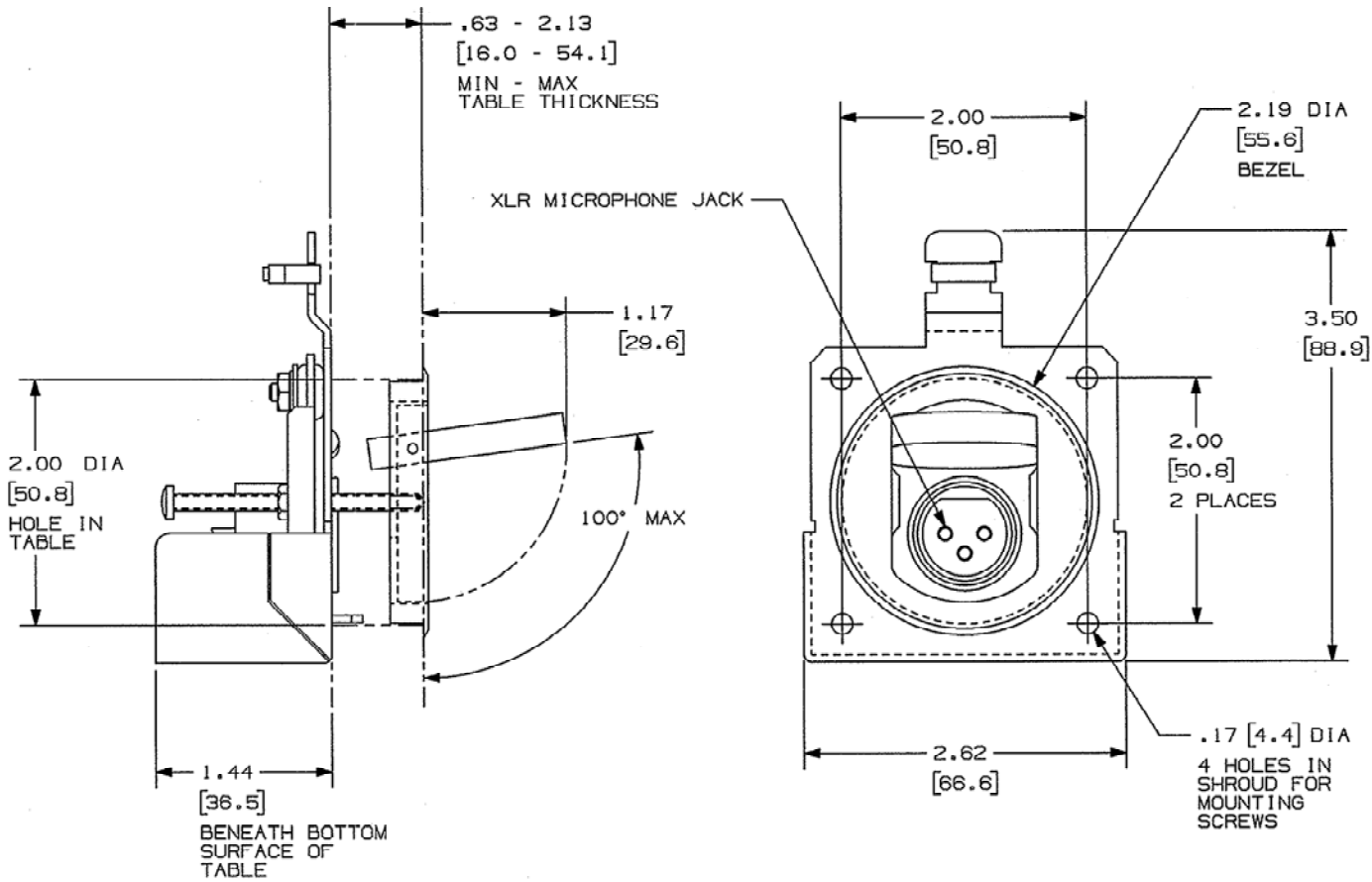

CATALOG NUMBER	BEZEL/COVER MATERIAL	BEZEL/COVER FINISH
TTBXLRAL	ALUMINUM	CLEAR
TTBXLRBK	ALUMINUM	BLACK
TTBXLRBR	BRASS	CLEAR

ALL DIMENSIONS ARE IN INCHES AND (MILLIMETERS)

CODE 74545

LIST OF PARTS

DESCRIPTION	MATERIAL	FINISH
BEZEL/COVER	SEE CHART	SEE CHART
SHROUD	STEEL	BLACK
BEZEL MOUNTING SCREWS	STAINLESS STEEL	----
SHROUD MOUNTING SCREWS	STEEL	ZINC
CLAMP NUTS	BRASS	NICKEL
WIRE TIE	NYLON	NATURAL

DIMENSION SHEET FOR CAT. NO.

REPAIRABLE NON-REPAIRABLE

B

M-11234

1

1	RELEASED PER DCN15584	SM	3/3/09
SYM	REVISIONS	APP	DATE

THE DESIGN AND DIMENSIONS OF THE PRODUCT SHOWN ON THIS DRAWING ARE SUBJECT TO CHANGE WITHOUT NOTICE

TITLE
TABLE TOP BOX,
XLR MICROPHONE JACK

TOLERANCES UNLESS OTHERWISE SPECIFIED FRACTIONS ± 1/64 DECIMALS ± .005 ANGLES ± 2°	WIRING DEVICE-KELLEMS HUBBELL INCORPORATED BRIDGEPORT, CT	
	DR. BY SRE	APP. BY SM
	TR. BY	SCALE 1:1
	CHK'D BY SM	DATE 2/23/09