

M-8796 1

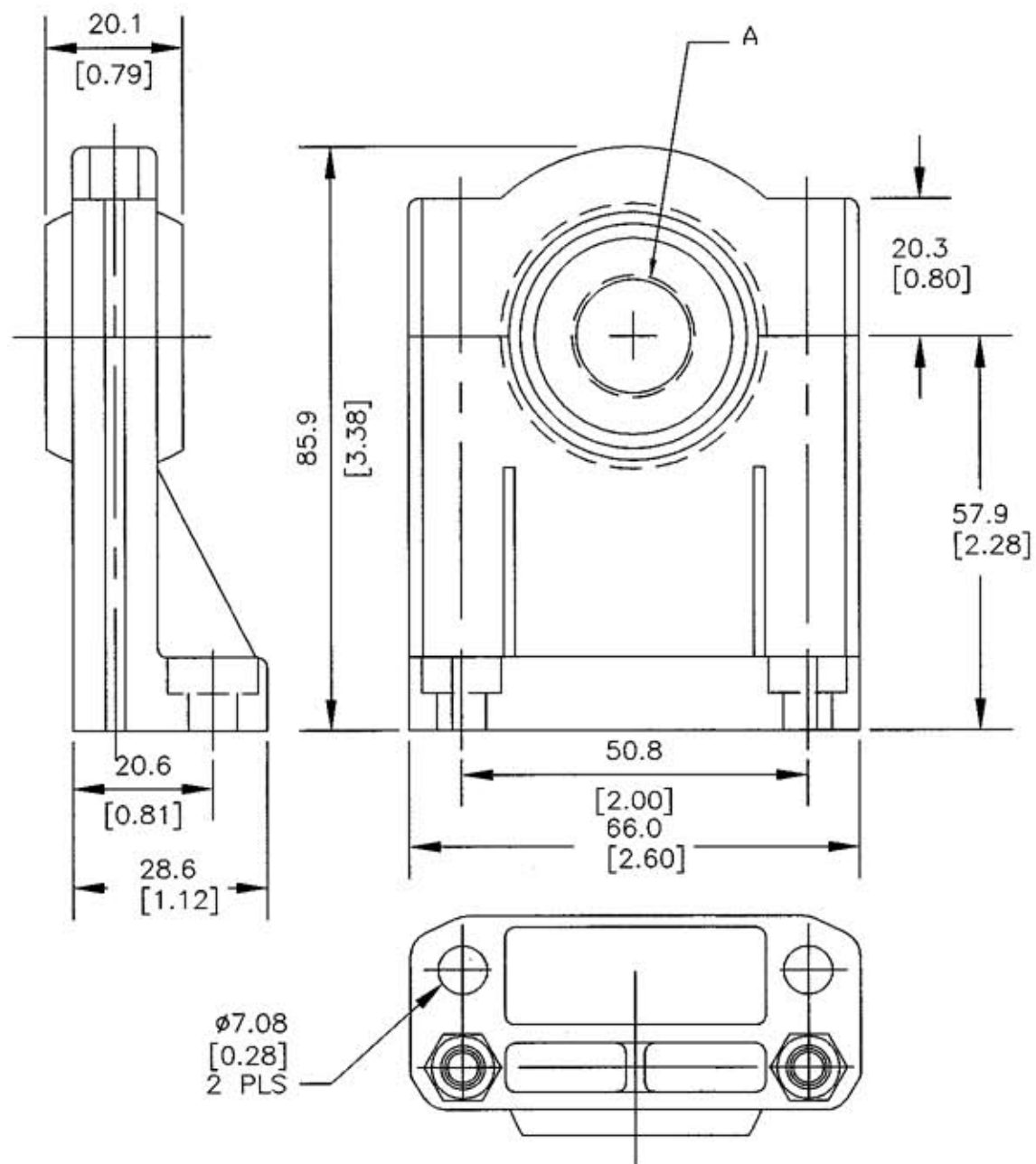

HUBBELL P/N	A	WEIGHT (OZ.)
UB12E	M12x1	3.9
UB18E	M18x1	3.6
UB30E	M30x1.5	3.4

LIST OF PARTS		
DESCRIPTION	MATERIAL	FINISH
BRACKET BASE, SWIVEL	NYLON (GLASS FILLED)	

1	5/3/02 "X" REMOVED; LAST "X" REVISION WAS X-0. RELEASED FOR PRODUCTION PER DCN #9320. GDR MJL	<i>MJL</i>	5/23/02
SYM	REVISIONS	APP	DATE

THE DESIGN AND DIMENSIONS OF THE PRODUCT SHOWN ON THIS DRAWING ARE SUBJECT TO CHANGE WITHOUT NOTICE

TITLE
SWIVEL-STYLE UNIVERSAL BRACKETS, EXT BASE

TOLERANCES UNLESS OTHERWISE SPECIFIED FRACTIONS ±/64 DECIMALS ±005 ANGLES ±2°	WIRING DEVICE-KELLEMS HUBBELL INCORPORATED BRIDGEPORT, CT	
	DR. BY GDR	APP. BY <i>MJL</i>
	TR. BY	SCALE NONE
CHK'D BY	DATE 5/3/02	

UNLESS OTHERWISE SPECIFIED DIMENSIONS ARE IN mm (INCHES)

DIMENSION SHEET FOR CAT. NO. REPAIRABLE NON-REPAIRABLE **M-8796**