

M-11677 1

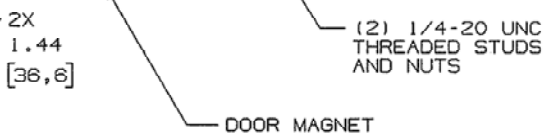
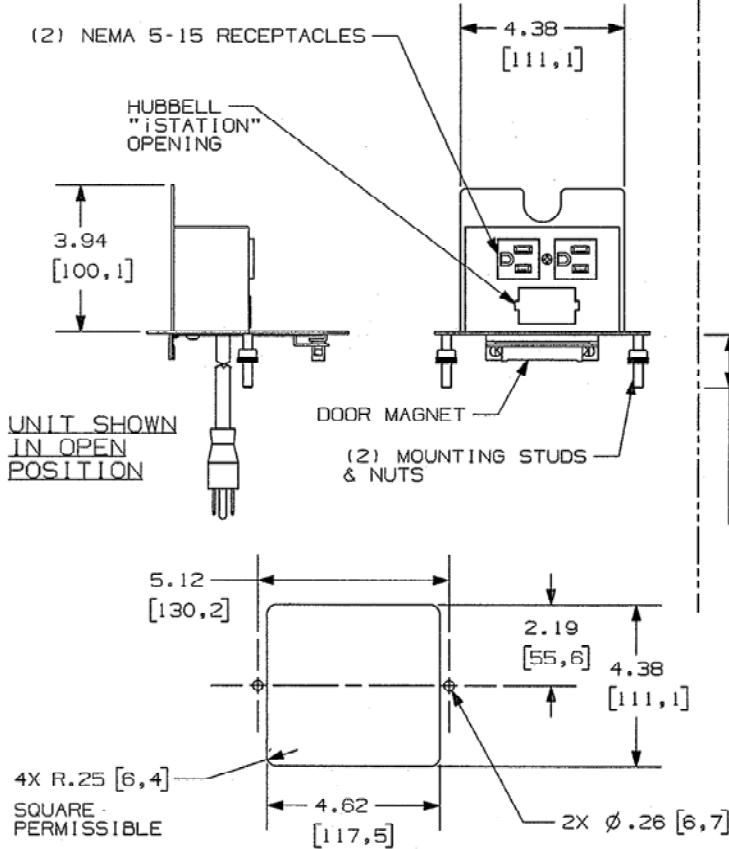
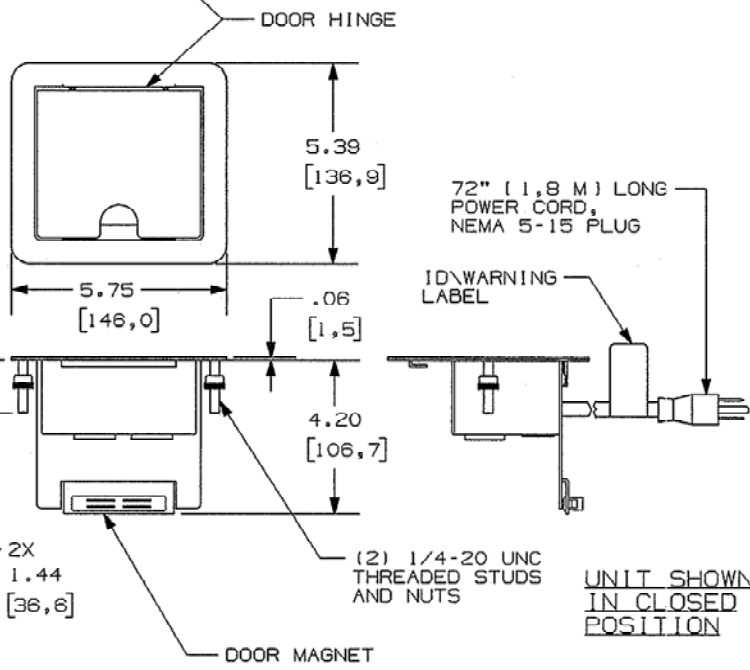
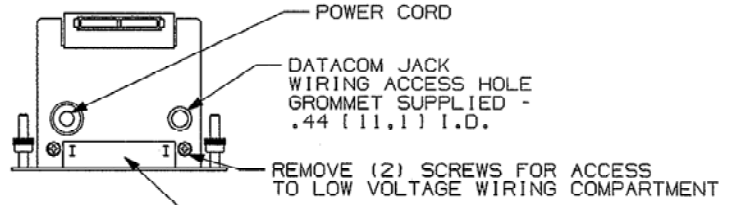

CATALOG NO.	FINISH
WSBC21UBK	BLACK
WSBC21USV	SILVER

NOTES - UNLESS OTHERWISE SPECIFIED:
 1) ALL DIMENSIONS ARE IN INCHES AND [MILLIMETERS]
 2) LOW VOLTAGE PLATE ACCEPTS HUBBELL
 "iSTATION" MODULES, 1 UNIT.

RECOMMENDED
 TABLE CUTOUT -
 MAX TABLE THICKNESS 1.25 [31,7]

CODE 74545

LIST OF PARTS

DESCRIPTION	MATERIAL	FINISH
HOUSING	STEEL	SEE TABLE
MOUNTING FRAME	STEEL	SEE TABLE
GROMMETS	NYLON	BLACK
POWER CORD	TYPE SJT	BLACK
FLAG LABEL	MYLAR	WHITE
FASTENERS	STEEL	ZINC
RECEPTACLES	THERMOPLASTIC	BLACK
FASTENERS	STEEL	BLACK OXIDE
ELASTOMERIC PADS	ELASTOMERIC FOAM	BLACK
MAGNETS	-----	-----

REVISIONS			
NO.	DESCRIPTION	APP.	DATE
1	RELEASED PER DCN16898	[Signature]	8/19/10

THE DESIGN AND DIMENSIONS OF THE
 PRODUCT SHOWN ON THIS DRAWING ARE
 SUBJECT TO CHANGE WITHOUT NOTICE

TITLE
 SQUARE LIFT-UP
 STYLE UNIT

TOLERANCES UNLESS OTHERWISE SPECIFIED		WIRING DEVICE-KELLENS HUBBELL INCORPORATED BRIDGEPORT, CT	
FRACTIONS	± 1/64	DR. BY	SRE
DECIMALS	± .005	APP. BY	[Signature]
ANGLES	± 2'	TR. BY	SCALE NONE
		CHK'D BY	DATE 8/18/10

DIMENSION SHEET FOR CONT. NO. SEE TABLE REPAIRABLE NON-REPAIRABLE B M-11677 1