

COMPONENT LIST

| ITEM NO. | DESCRIPTION | MAT'L | COMPONENT NO. | QTY. |
|----------|-------------|-------|---------------|------|
| 1 | STRAND | T BRZ | 302-01-004 | - |
| 2 | EYE | CU | 342-43-005 | 1 |
| 3 | TAG | MYLAR | | 1 |
| | | | | |
| | | | | |
| | | | | |
| | | | | |
| | | | | |
| | | | | |

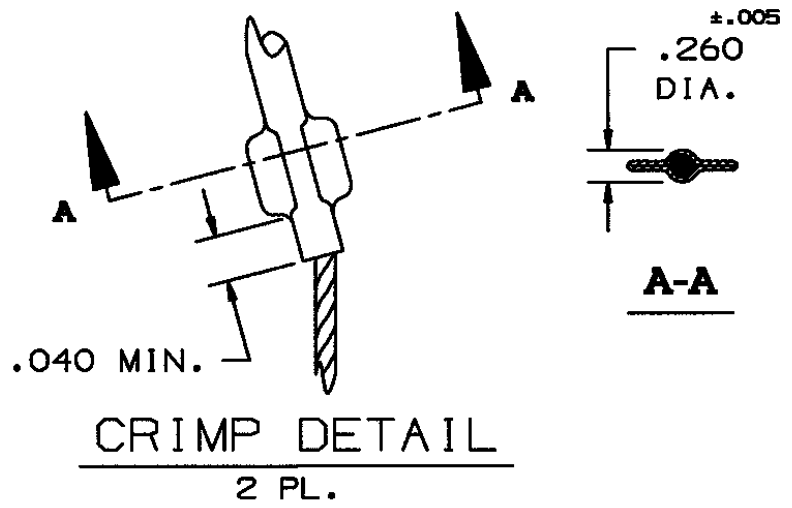

IN ACCEPTING OUR DRAWINGS OR BLUEPRINTS FOR QUOTATION OR OTHER PURPOSES, YOU AGREE NOT TO DISCLOSE TO OTHERS THE IDEAS, INFORMATION, OR DESIGNS THEREIN SHOWN, AND THAT YOU WILL MAKE NO USE OF OUR DRAWINGS OR BLUEPRINTS OR OF THE IDEAS, INFORMATION, OR DESIGNS THEREIN SHOWN WITHOUT OUR PERMISSION.

TITLE GRIP, HEAVY, SUPPORT, CLOSED MESH, SINGLE-DOUBLE WEAVE, SINGLE "U" EYE DIA. RA .87-1.00 APPROX BRK STR. 1790# ±20%

TOLERANCES UNLESS OTHERWISE SPECIFIED
 .X = ±.5
 .XX = ±.05
 .XXX = ±.015
 ANGLE TOL. ± 2°

HUBBELL INCORPORATED
 KELLEMS DIVISION
 STONINGTON, CT

| | |
|-------------|--------------|
| DR. BY FBR | APP. BY FFS |
| TR. BY | SCALE N/A |
| CHK. BY JLW | DATE 11-2-93 |

| | |
|-------------------|----------|
| DR. NO. | REV. |
| 022-17-012 | K |