

COMPONENT LIST				
ITEM NO.	DESCRIPTION	MAT'L	COMPONENT NO.	QTY.
1	STRAND	SST		-
2	EYE	SST		1
3	ROD	SST		1
4	EQUALIZER	SST		2

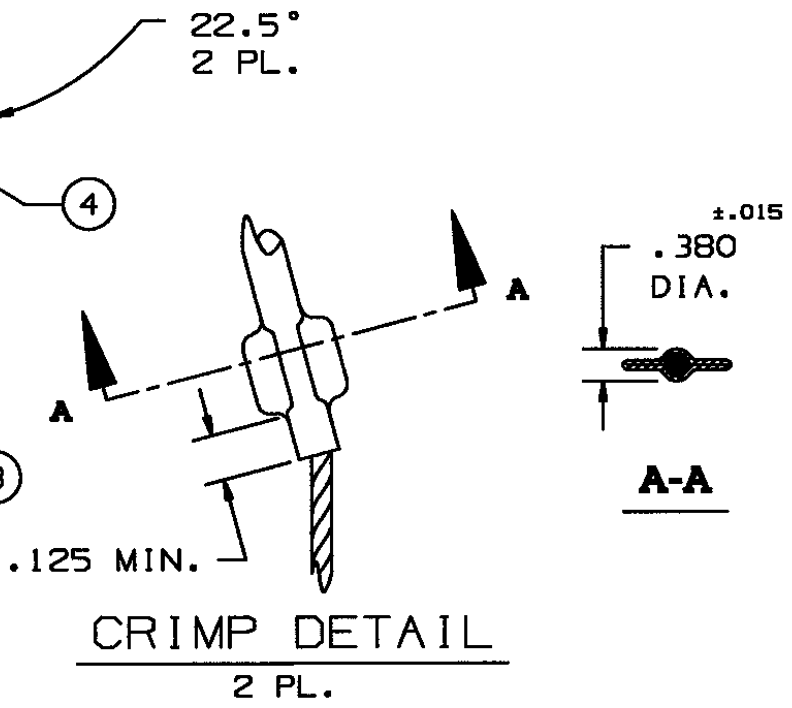

IN ACCEPTING OUR DRAWINGS OR BLUEPRINTS FOR QUOTATION OR OTHER PURPOSES, YOU AGREE NOT TO DISCLOSE TO OTHERS THE IDEAS, INFORMATION, OR DESIGNS THEREIN SHOWN, AND THAT YOU WILL MAKE NO USE OF OUR DRAWINGS OR BLUEPRINTS OR OF THE IDEAS, INFORMATION, OR DESIGNS THEREIN SHOWN WITHOUT OUR PERMISSION.

TITLE GRIP, SST, STD. SUPPORT, SPLIT-ROD CLOSING, SINGLE WEAVE, SINGLE EYE DIA. RA 2.00-2.49 APPROX BRK STR. 8950# ±20%

TOLERANCES UNLESS OTHERWISE SPECIFIED .X = ±.5 .XX = ±.05 .XXX = ±.015 ANGLE TOL. ± 2°	HUBBELL INCORPORATED KELLEMS DIVISION STONINGTON, CT	
	DR. BY FBR	APP. BY JLW
PROJECT NO.	TR. BY	SCALE N/A
	CHK. BY JLW	DATE 11-9-93

DR. NO.	REV.
024-03-021	J

SHEET 1 OF 1